

KE-434C BE-435C

パーツブック
PARTS BOOK



本縫電子模様縫ミシン [KE-434C]

本縫電子模様縫ミシン 間欠押え付 [KE-435C]

ELECTRONIC LOCKSTITCH PATTERN TACKER [KE-434C]

ELECTRONIC LOCKSTITCH PATTERN TACKER WITH STEPPING FOOT
[KE-435C]

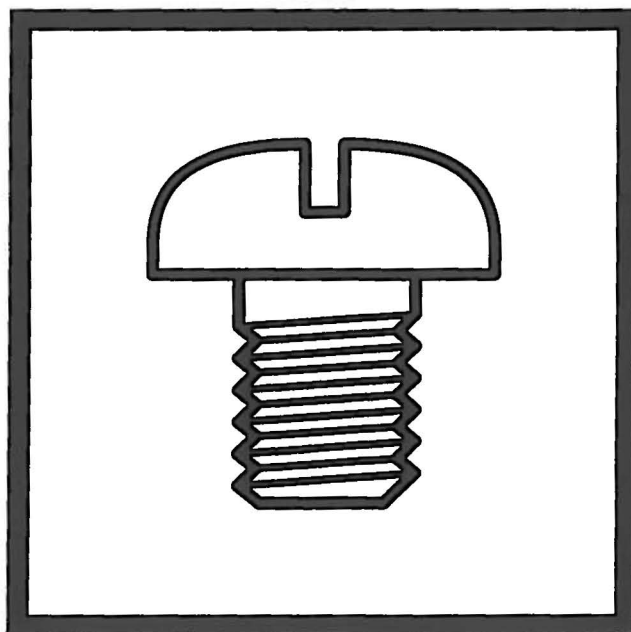

brother[®]

最新の部品情報は Parts Navigation でご覧いただけます。 <http://partsbook.brother.co.jp/partsnavi/jpn/index.html>
The latest parts information, refer to the Parts Navigation. <http://partsbook.brother.co.jp/partsnavi/eng/index.html>

From the library of: Superior Sewing Machine & Supply LLC

本縫電子模様縫ミシン / Electronic Lockstitch Pattern Tacker



- ① — 1: 中厚物 / Medium-weight materials
2: 厚物 / Heavy-weight materials

本縫電子模様縫ミシン 間欠押え付 / Electronic Lockstitch Pattern Tacker
with Stepping Foot



パーツブックご利用に際して

1. この本は、2004年11月のデータに基づいて作成されたものです。
2. 部品は予告なしに設計変更される場合があります。
3. 組単位で補給する部品は、 破線で示してあります。
4. 部品コード欄が * となっている場合は、仕様別部品一覧表及びゲージ部品一覧表でお調べ下さい。

目 次

A. 主体関係	1	Q2. コントロールボックス関係	57
B1. 上軸・針棒関係	5	R1. 空圧関係 (KE-434C).....	61
B2. 上軸・針棒関係	7	R2. 空圧関係 (KE-435C).....	65
C1. 送り関係	9	S. 電装品関係	67
C2. 送り関係 (電磁式用).....	13	T. 操作パネル関係	71
C3. 送り関係 (電磁式用).....	15	U. 動力台関係	71
C4. 送り関係 (KE-434C, KE-435Cエア一式用).....	17	V1. 踏板関係 (KE-434C電磁式用).....	73
C5. 送り関係 (KE-434C中押工反転装置用).....	19	V2. 踏板関係 (KE-434C電磁式用オプション部品)	75
C6. 送り関係	21	V3. 踏板関係 (エア一式用).....	77
D1. 押工上げ関係	23	V4. 踏板関係 (オプション部品).....	79
D2. 押工上げ関係 (KE-435C).....	25	W1. 付属装置関係 (オプション部品) ...	81
E. 下軸関係	27	W2. 付属装置関係 (KE-434C用オプション部品).....	83
F. 給油潤滑関係	31	W3. 付属装置関係 (KE-435C用オプション部品).....	85
G. 糸通シ関係	33	Z. 付属品関係	87
H. 糸巻関係	35	Sp1. 仕様別部品一覧表.....	91
J. 糸切り関係	37	Sp1. 仕様別部品一覧表.....	92
K. 糸払い関係	41	Ga1. ゲージ部品一覧表.....	93
L. 糸締め関係	45	Ga2. ゲージ部品一覧表.....	95
M. 糸取り関係	49	Wa. 警告ラベル	96
N. 針位置検出器関係	51	索引	97
P. プリント基板関係	51		
Q1. コントロールボックス関係	53		

Notes for using this parts book

- 1 This book was prepared based on information available in November 2004.
- 2 Parts are subject to changes in design without prior notice.
- 3 Parts supplied as complete assemblies are circled by a dotted line .
- 4 If the symbol * is found in the " Parts No." column, refer to the different parts lists, gauge parts list on page 91-95.

CONTENTS

A. Machine body.....	1	R2. Air pressure mechanism (KE-435C) ..	65
B1. Upper shaft and needle bar mechanism	5	S. Power supply equipment mechanism	67
B2. Upper shaft and needle bar mechanism	7	T. Operation panel mechanism	71
C1. Feed mechanism	9	U. Power table	71
C2. Feed mechanism (For Solenoid type) ...	13	V1. Foot switch pedal mechanism	
C3. Feed mechanism (For Solenoid type) ...	15	(For Solenoid type of KE-434C)	73
C4. Feed mechanism (For Pneumatic type of KE-434C & KE-435C)	17	V2. Foot switch pedal mechanism	
C5. Feed mechanism (For Inner clamping device of KE-434C)	19	(Option parts for Solenoid type of KE-434C)	75
C6. Feed mechanism	21	V3. Foot switch pedal mechanism	
D1. Work clamp lifter mechanism	23	(For pneumatic type)	77
D2. Work clamp lifter mechanism (KE-435C)	25	V4. Foot switch pedal mechanism	
E. Lower shaft mechanism	27	(Option parts)	79
F. Lubrication	31	W1. Attachment set (Option parts)	81
G. Threading mechanism	33	W2. Attachment set	
H. Bobbin winder mechanism	35	(Option parts for KE=434C)	83
J. Thread trimmer mechanism	37	W3. Attachment set	
K. Thread wiper mechanism	41	(Option parts for KE=435C)	85
L. Thread nipper mechanism	45	Z. Accessories	87
M. Thread take-up mechanism	49	Sp1. Diifferent Parts list	91
N. Synchronizer	51	Sp2. Diifferent Parts list	92
P. Printed circuit board mechanism	51	Ga1. Gauge parts list	93
Q1. Control box mechanism	53	Ga2. Gauge parts list	95
Q2. Control box mechanism	57	Wa. Warning labels	96
R1. Air pressure mechanism (KE-434C)	61	Index	97

A. 主体関係 / Machine body

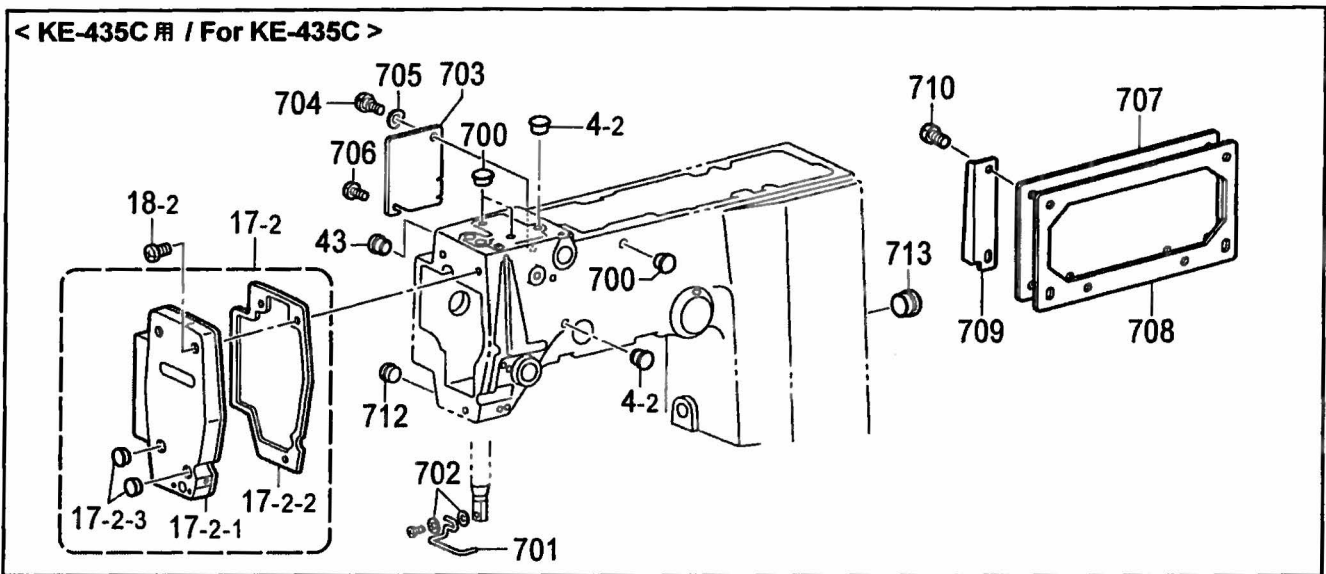
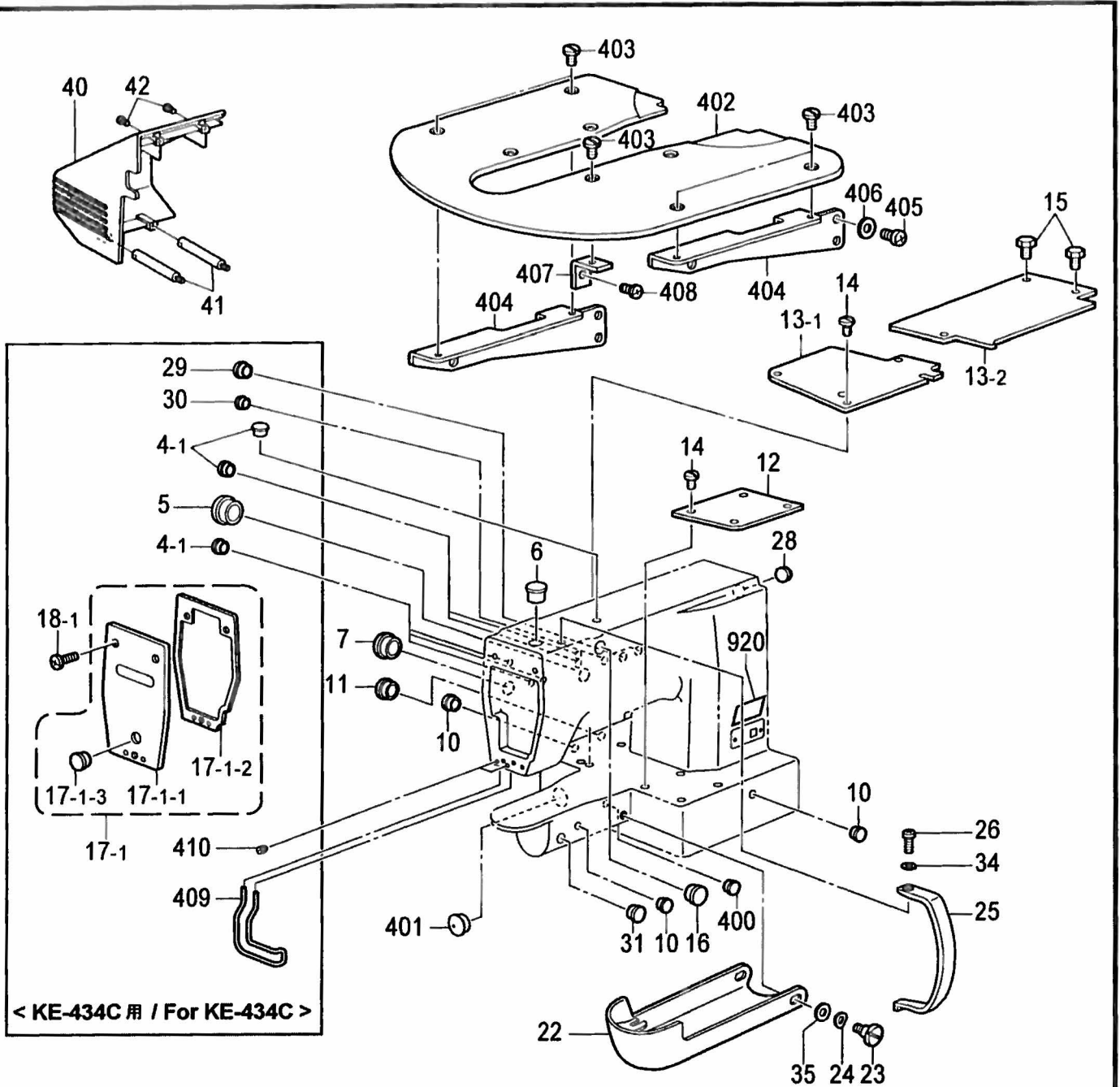

A . 主体関係 / Machine body

REF.NO	CODE	Q'TY	ヒンメイ	NAME OF PARTS	RM
4-1	104450101	6	<KE-434C用> ゴムセン8	<For KE-434C> RUBBER CAP, 8	
5	140392009	1	オイルフタ	OIL CAP	
4-2	104450101	2	<KE-435C用> ゴムセン8	<For KE-435C> RUBBER CAP, 8	
6	117934001	1	ゴムセン13.5	RUBBER CAP, 13.5	
7	140392009	2	オイルフタ	OIL CAP	
10	104450101	3	ゴムセン8	RUBBER CAP, 8	
11	104449001	1	ゴムセン15.5	RUBBER CAP, 15.5	
12	S37915009	1	ベッドカバー-R	BED COVER, R	
13-1	S53119001	1	ベッドカバー-LF	BED COVER, LF	
13-2	S53120101	1	ベッドカバー-LR	BED COVER, LR	
14	106629002	9	シメネジ4.37	SCREW, SM4.37	
15	017680512	2	ボルト4.37X5	BOLT, SM4.37X5	
16	S23337001	1	ゴムセン18.5	RUBBER CAP, 18.5	
17-1	S51457109	1	<KE-434C用> フェイス433Eミ	<For KE-434C> FACE PLATE ASSY, 433E	
17-1-1	S51458109	1	フェイス433E	FACE PLATE, 433E	
17-1-2	S49962000	1	フェイスパッキン	FACE PLATE PACKING	
17-1-3	117934001	1	ゴムセン13.5	RUBBER CAP, 13.5	
18-1	060671212	3	バインド357-40X12	SCREW, BIND SM3.57-40X12	
17-2	S42750209	1	<KE-435C用> フェイスミ	<For KE-435C> FACE PLATE ASSY	
17-2-1	S42751109	1	フェイス	FACE PLATE	
17-2-2	S42752000	1	フェイスパッキン	F-PLATE PACKING	
17-2-3	117934001	2	ゴムセン13.5	RUBBER CAP, 13.5	
18-2	062711012	3	ナベコ476-32X10	SCREW, PAN SM4.76-32X10	
22	152842059	1	オオカマカバーミ	SHUTTLE RACE COVER ASSY	
23	S57925001	2	ダンネジ6.35	SHOULDER SCREW, SM6.35	
24	109239002	2	ナミハネサガネ	WAVE WASHER	
25	S55208000	1	テンピンカバー	THREAD TAKE-UP LEVER COVER	
26	062681012	1	ナベコ437-40X10	SCREW, PAN SM4.37-40X10	
28	S20164001	1	ゴムセン13	RUBBER CAP, 13	
29	150592001	2	<KE-434C用> ゴムセン16	<For KE-434C> RUBBER CAP, 16	
30	104821001	1	ゴムセン10.5	RUBBER CAP, 10.5	
31	S44010001	1	ゴムセン11.5	RUBBER CAP, 11.5	
34	100645003	1	サガネ	WASHER	
35	025080132	2	ヒラサガネシユウ8	WASHER, PLAIN S 8	
40	S51098000	1	ソクメンカバー-IM	FRAME SIDE COVER, IM	
41	S59920001	2	ベルトカバー-シチュウ	BELT COVER SUPPORT PILLAR	
42	062711012	4	ナベコ476-32X10	SCREW, PAN SM4.76-32X10	
43	150592001	1	<KE-435C用> ゴムセン16	<For KE-435C> RUBBER CAP, 16	
400	104450101	1	ゴムセン8	RUBBER CAP, 8	
401	140392009	1	オイルフタ	OIL CAP	
402	S51461001	1	ハリイタホシヨイタ	NEEDLE PLATE AUXILIARY PLATE	
403	106629002	8	シメネジ4.37	SCREW, SM4.37	
404	S51459001	2	ホシヨイタササエ	AUXILIARY PLATE SUPPORT	
405	062761012	4	ナベコ595-28X10	SCREW, PAN SM5.95-28X10	
406	025060232	4	ヒラサガネチユウ6	WASHER, PLAIN M 6	
407	S10091201	4	ハリイタホシヨイタササエ	AUXILIARY PLATE SUPPORT	

KE-434C/435C-050

A. 主体関係 / Machine body

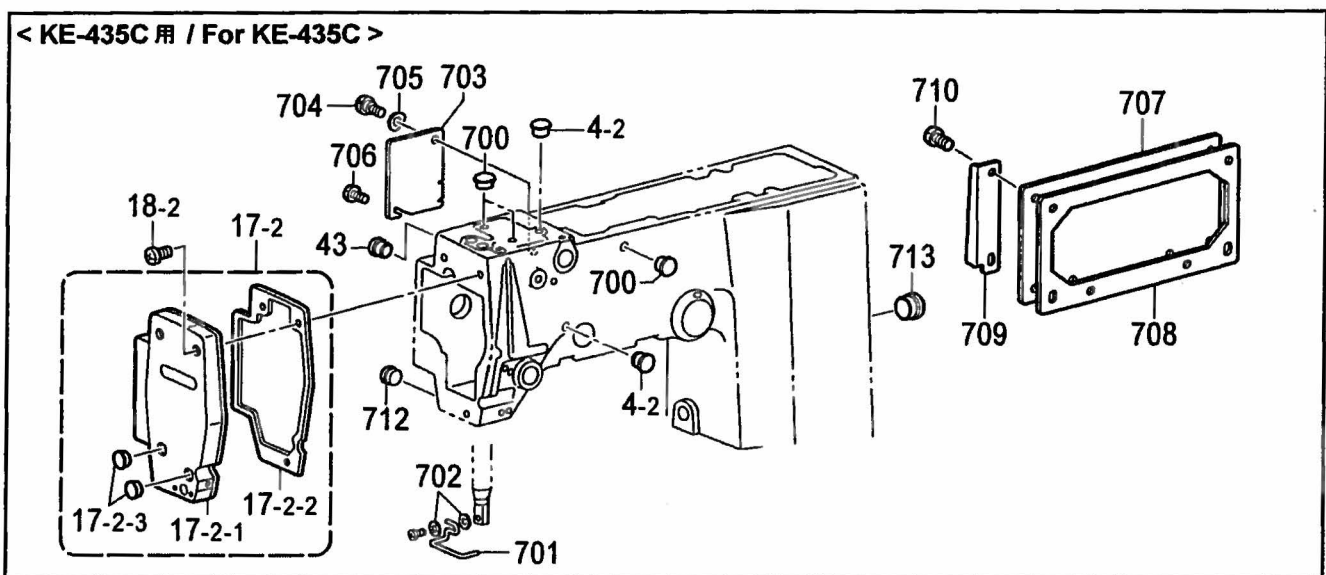
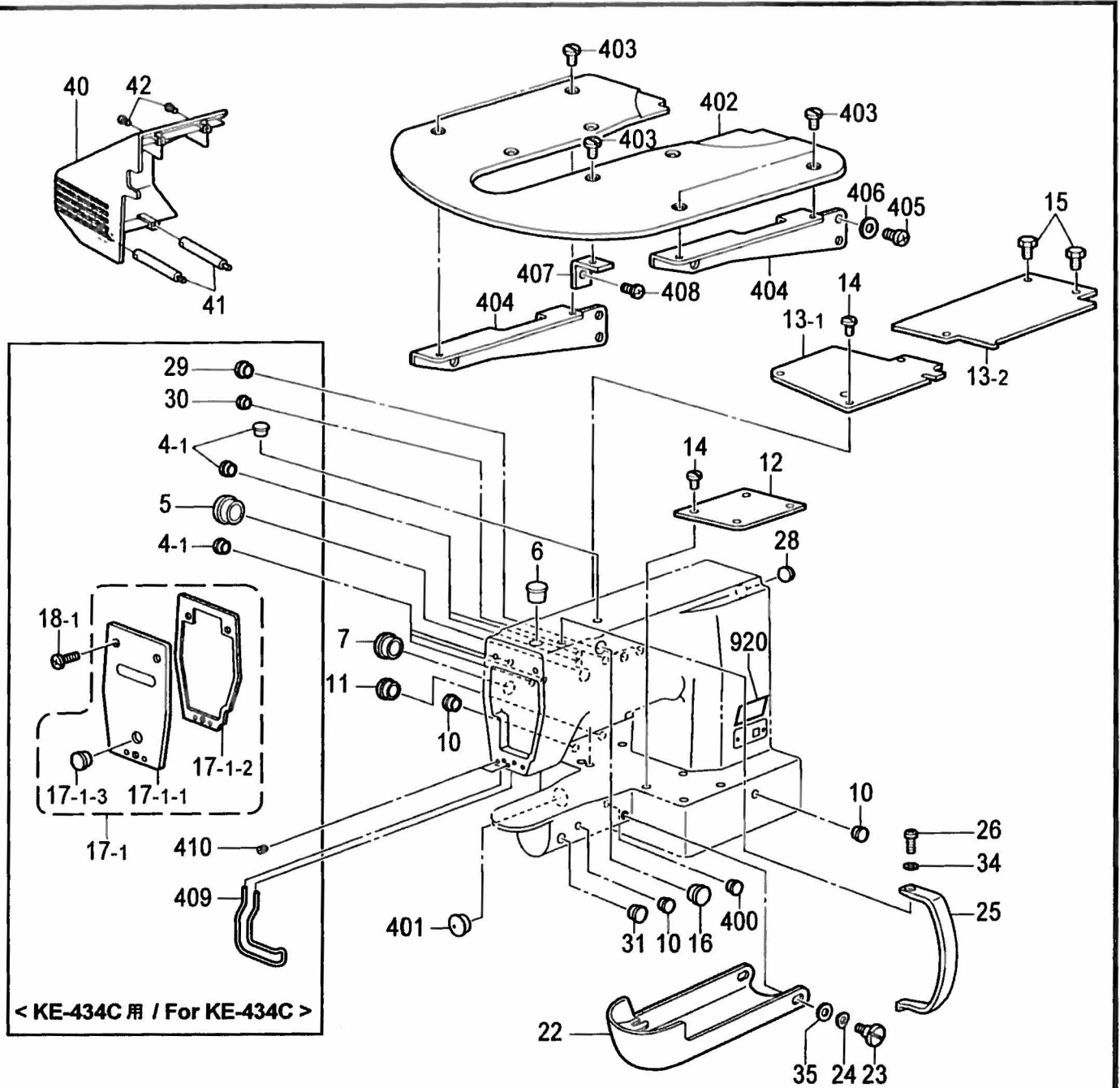

A . 主体関係 / Machine body

REF.NO	CODE	Q'TY	ヒンメイ	NAME OF PARTS	RM
408	060680712	4	バインド437-40X7	SCREW, BIND SM4.37-40X7	
			<KE-434C用>	<For KE-434C>	
409	S53117101	1	フィンガーガード	FINGER GUARD	
410	011679312	2	トメネジ3.57ヒラ	SET SCREW, (FT) SM3.57	
			<KE-435C用>	<For KE-435C>	
700	117936001	3	ゴムセン9.4	RUBBER CAP, 9.4	
701	S02445001	1	フィンガーガード	FINGER GUARD	
702	025350236	2	ヒラサガネチユウ3.5	WASHER, PLAIN M 3.5	
703	S54145001	1	カンケツカバー	STEPPING COVER	
704	107321003	1	ダンネジ4.76	SHOULDER SCREW, SM4.76	
705	107017002	1	ナミバネサガネ	WAVE WASHER	
706	060670612	1	バインド357-40X6	SCREW, BIND SM3.57-40X6	
707	S43907209	1	ソクメンカバー	FRAME SIDE COVER	
708	S41290301	1	OYSTリツケイタハツキン	OYS SETTING PLATE PACKING	
709	S41060109	1	メカクシタ	BLIND PLATE	
710	062710812	4	ナヘコ476-32X8	SCREW, PAN SM4.76-32X8	
712	104449001	1	ゴムセン15.5	RUBBER CAP, 15.5	
713	104449001	1	ゴムセン15.5	RUBBER CAP, 15.5	
920	S44629001	1	Eマーク	E-MARK	

KE-434C/435C-050

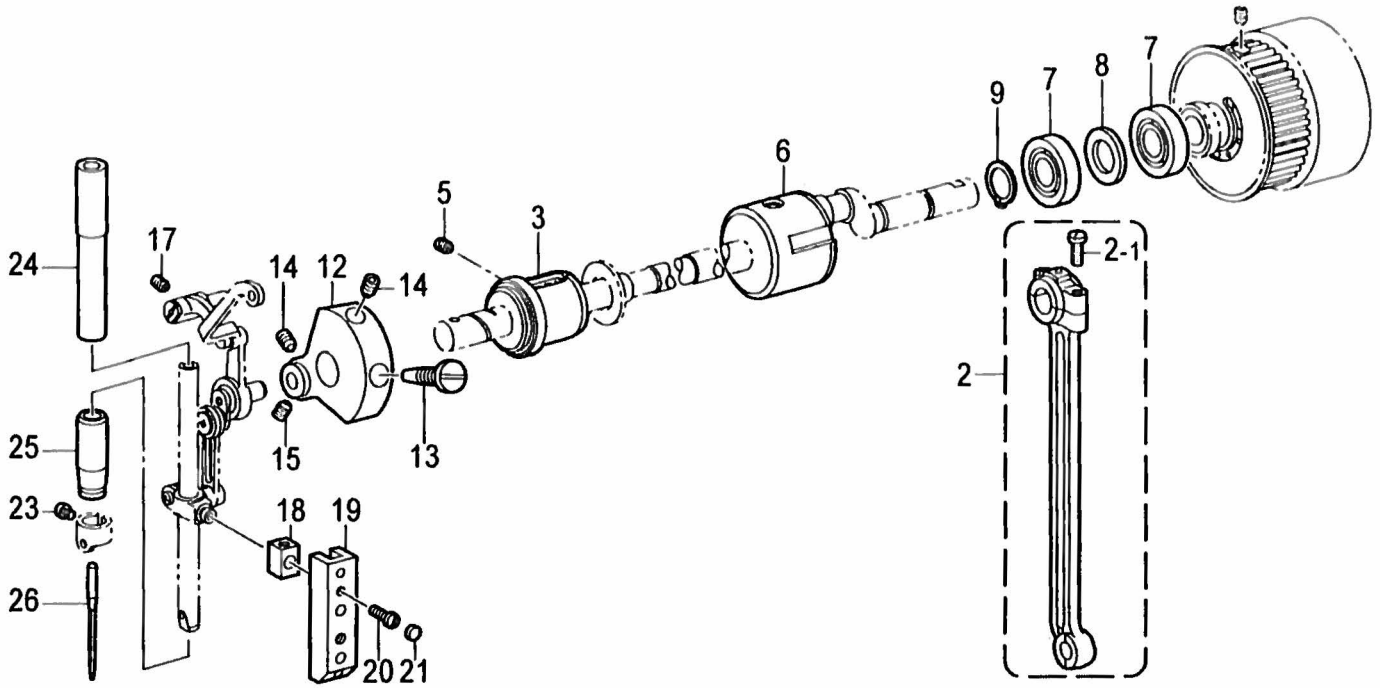

< KE-434C 用 / For KE-434C >

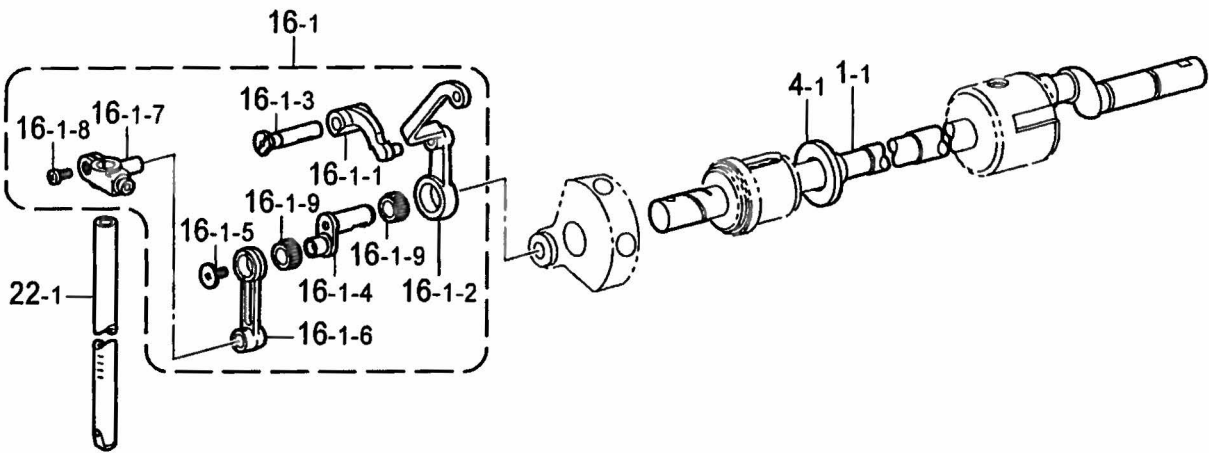

< KE-435C 用 / For KE-435C >

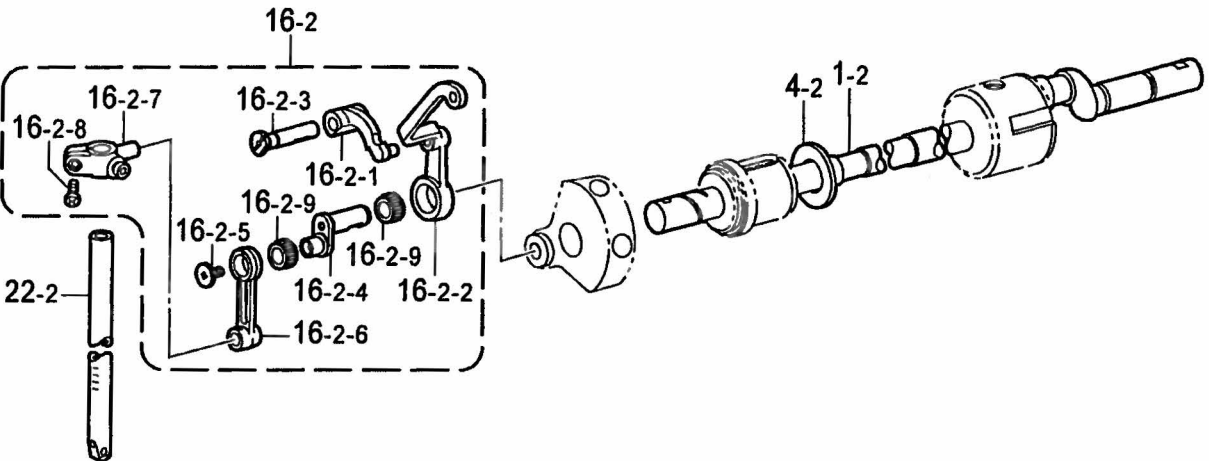

B1 . 上軸・針棒関係 / Upper shaft and needle bar mechanism

REF.NO	CODE	Q'TY	ヒンメイ	NAME OF PARTS	RM
2	SA2932001	1	クランクロッドクミ	CRANK ROD ASSY	
2-1	144712001	2	シメネジ 4.76	SCREW, SM4.76	
3	S49582001	1	ウワジクメタルF	UPPER SHAFT BUSH, F	
5	014780632	1	アナクホミ635-28X6	SET SCREW SOCKET SM6.35-28X6	
6	140726000	1	ウワジクメタルM	UPPER SHAFT BUSH, M	
7	072630260	2	ベアリング 6302VV	BALL BEARING, 6302VV	
8	116920001	1	オクリジクスラストリング	RING, THRUST	
9	048150142	1	トメワジクヨウC15	RETAINING RING EXTERNAL C15	
12	S49584101	1	ツリアイクランクD	THREAD TAKE-UP CRANK, D	
13	100250001	1	シメネジ 7.14	SCREW, SM7.14	
14	014770632	2	アナクホミ635-40X6	SET SCREW SOCKET SM6.35-40X6	
15	123006001	1	トメネジ 6.35クホミ	SET SCREW, (CP) SM6.35	
17	014780632	1	アナクホミ635-28X6	SET SCREW SOCKET SM6.35-28X6	
18	102630001	1	ハリホウアンナイカクマ	NEEDLE BAR GUIDE SLIDE BLOCK	
19	S49593000	1	ハリホウアンナイ	NEEDLE BAR GUIDE	
20	100242003	2	シメネジ 3.57	SCREW, SM3.57-40X5	
21	155578000	2	ゴムセン 7.2	RUBBER CAP, 7.2	
23	144458001	1	アタマツキトメネジ 3.57	SET SCREW, SM3.57-40X4.5	
24	152242001	1	ハリホウメタルU	NEEDLE BAR BUSH, U	
25	152243001	1	ハリホウメタルD	NEEDLE BAR BUSH, D	
26	*	1	ミシンハリ	NEEDLE	
			<KE-434C用>	<For KE-434C>	
1-1	S49688101	1	ウワジク	UPPER SHAFT	
4-1	S49583001	1	スラストサガネ	THRUST WASHER	
16-1	S49585001	1	ハリホウレンカンクミ	NEEDLE BAR CONNECTING ROD ASSY	
16-1-1	S49587001	1	テンピンササエ	THREAD TAKE-UP SUPPORT	
16-1-2	S49588001	1	テンピントウ	THREAD TAKE-UP LEVER	
16-1-3	S47091001	1	テンピンササエジク	THREAD TAKE-UP SUPPORT SHAFT	
16-1-4	S49589001	1	ハリホウクランク	NEEDLE BAR CONNECTING ROD	
16-1-5	145465001	1	シメネジ 3.57L	SCREW, SM3.57-40X6 L	
16-1-6	S49689001	1	ハリホウレンカン	NEEDLE BAR CONNECTING ROD	
16-1-7	S37926101	1	ハリホウタキ	NEEDLE BAR CLAMP	
16-1-8	062680812	1	ナベコ 437-40X8	SCREW PAN SM4.37-40X8	
16-1-9	147777000	2	ニードルベアリング	NEEDLE BEARING	
22-1	152240101	1	ハリホウA	NEEDLE BAR, A	
			<KE-435C用>	<For KE-435C>	
1-2	S55103201	1	ウワジク	UPPER SHAFT	
4-2	S55104001	1	スラストサガネ	THRUST WASHER	
16-2	S55105001	1	ハリホウレンカンクミ	NEEDLE BAR CONNECTING ROD ASSY	
16-2-1	S49587001	1	テンピンササエ	THREAD TAKE-UP SUPPORT	
16-2-2	S49588001	1	テンピントウ	THREAD TAKE-UP LEVER	
16-2-3	S47091001	1	テンピンササエジク	THREAD TAKE-UP SUPPORT SHAFT	
16-2-4	S49589001	1	ハリホウクランク	NEEDLE BAR CONNECTING ROD	
16-2-5	145465001	1	シメネジ 3.57L	SCREW, SM3.57-40X6 L	
16-2-6	S49689001	1	ハリホウレンカン	NEEDLE BAR CONNECTING ROD	
16-2-7	S42756101	1	ハリホウタキ	NEEDLE BAR CLAMP	
16-2-8	062680712	1	ナベコ 437-40X7	SCREW, PAN SM4.73-40X7	
16-2-9	147777000	2	ニードルベアリング	NEEDLE BEARING	
22-2	S02269001	1	ハリホウ	NEEDLE BAR	

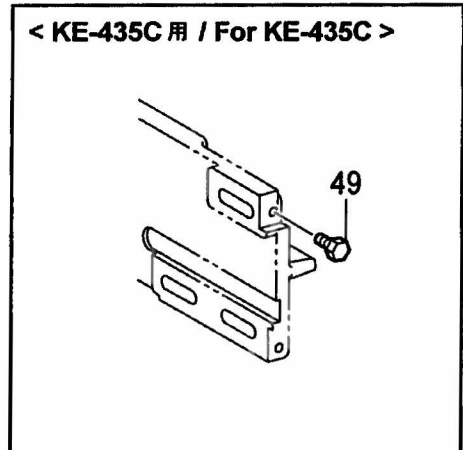
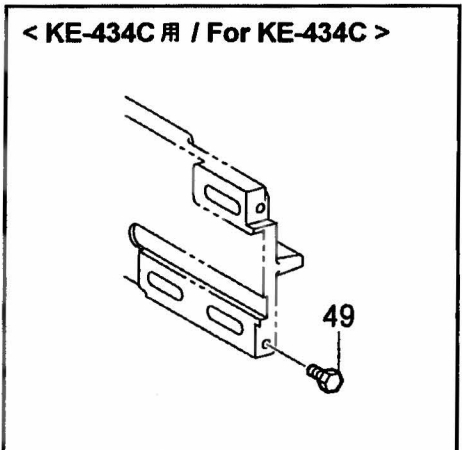
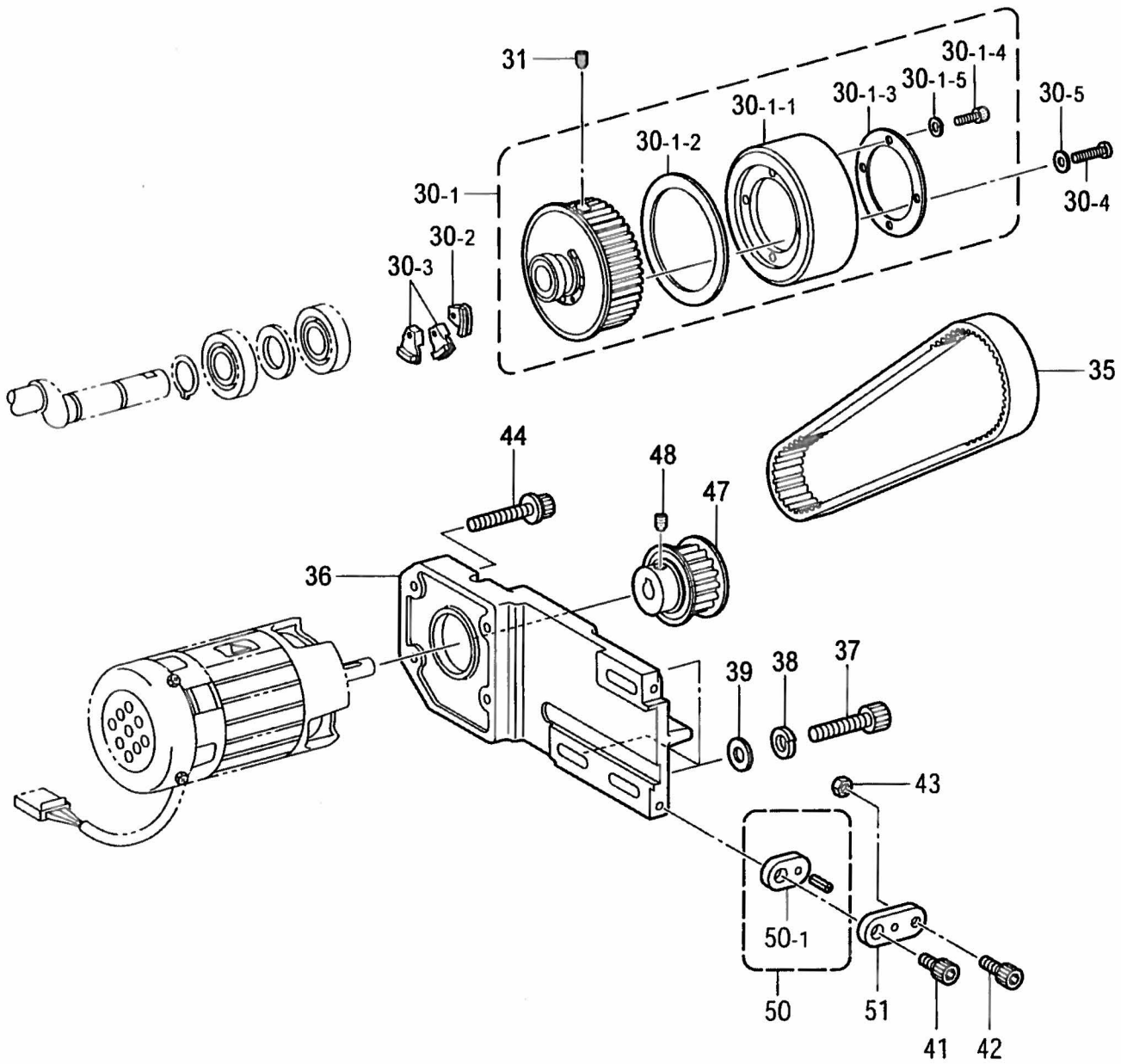

B2 . 上軸・針棒関係 / Upper shaft and needle bar mechanism

REF.NO	CODE	Q'TY	ヒンメイ	NAME OF PARTS	RM
30-1	S52834201	1	Uタイミングプーリクミ	TIMING PULLEY ASSY, U	
30-1-1	S56017000	1	ウワシクプーリ	UPPER SHAFT PULLEY	
30-1-2	S56018000	1	プーリスパサ	PULLEY SPACER	
30-1-3	S56019001	1	プーリサガネ	PULLEY WASHER	
30-1-4	018401236	3	アナホルト4X12	BOLT SOCKET M4X12	
30-1-5	028040246	3	ハネサガネ2-4	WASHER SPRING 2-4	
30-2	S38080001	1	ハリシタジシヤクミ	NEEDLE LOWER MAHNET ASSY,D	
30-3	S38082001	1	ハリウエジシヤクミ	NEEDLE UPPER MAGNET ASSY,U	
30-4	062681412	3	ナベコ437-40X14	SCREW PAN SM4.37-40X14	
30-5	025680132	3	ヒラサガネシヨウ4.37	WASHER,PLAIN S SM4.37	
31	S55572001	2	アナクホミ595-28X10	SET SCREW, SOCKET(CP)SM5.95X10	
35	S52838000	1	ウワシクタイミングベルト	UPPER SHAFT TIMING BELT	
36	S52839200	1	IMモータブラケット	MOTOR BRACKET, IM	
37	018083032	3	アナホルト8X30	BOLT SOCKET M8X30	
38	028080242	3	ハネサガネ2-8	WASHER SPRING 2-8	
39	025080232	3	ヒラサガネチユウ8	WASHER PLAIN M 8	
41	018062032	1	アナホルト6X20	BOLT SOCKET M6X20	
42	018062532	1	アナホルト6X25	BOLT SOCKET M6X25	
43	021060102	1	1シユナツト6	NUT 1 M6	
44	S47270001	4	アナホルトサクミ6X30	BOLT, SOCKET (S/P WASHER)M6X30	
47	S52836000	1	Mタイミングプーリ32クミ	MOTOR TIMING PULLEY 32 ASSY	
48	S55572001	1	アナクホミ595-28X10	SET SCREW, SOCKET(CP)SM5.95X10	
49	017680512	1	ホルト4.37-40X5	BOLT SM4.37-40X5	
50	S57976001	1	ベルトチヨウセツイタAクミ	BELT ADJUSTING PLATE A ASSY	
50-1	S57977001	1	ベルトチヨウセツイタA	BELT ADJUSTING PLATE, A	
51	S57978001	1	ベルトチヨウセツイタB	BELT ADJUSTING PLATE, B	

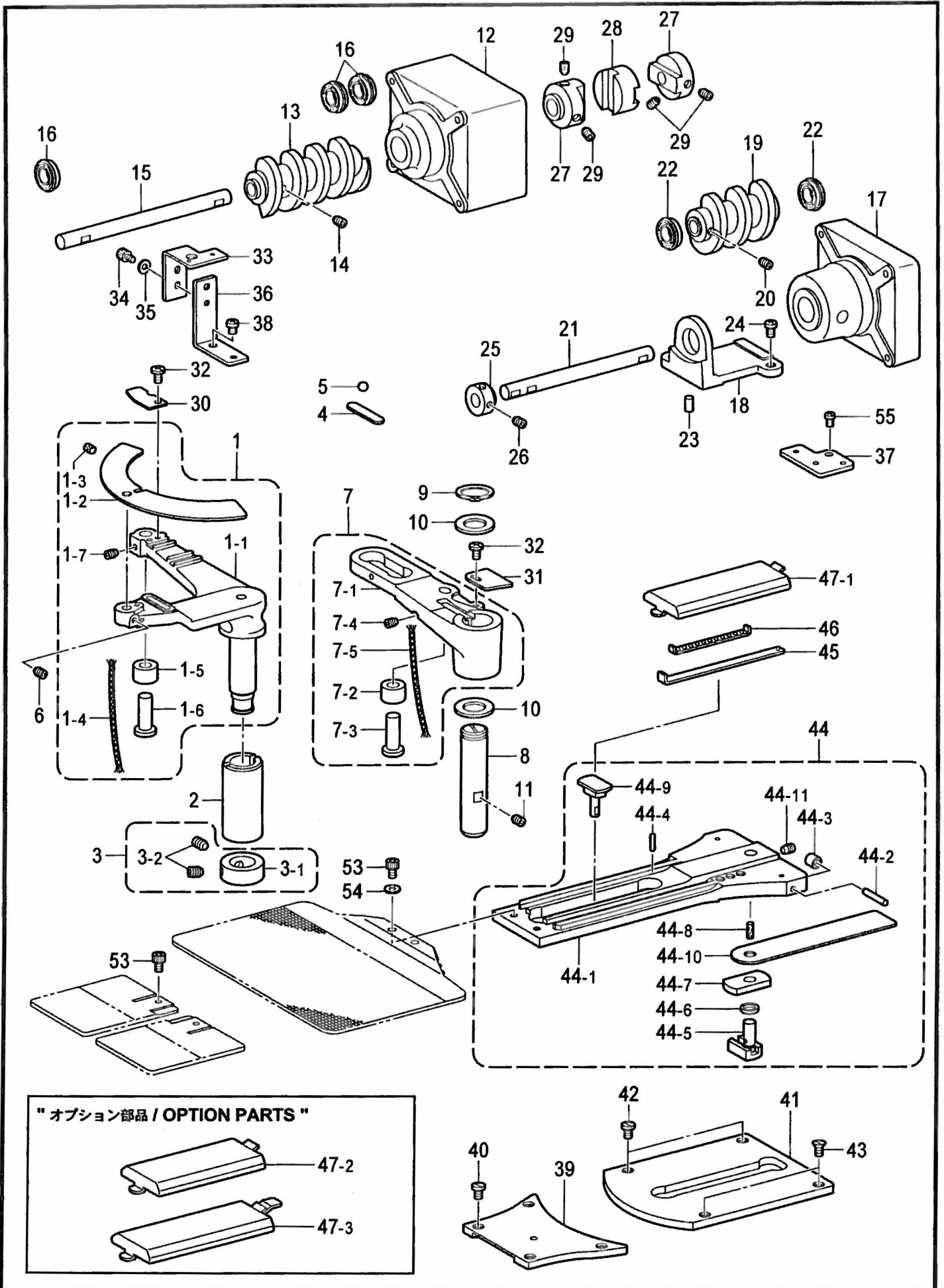

C1 . 送り関係 / Feed mechanism

REF.NO	CODE	Q'TY	ヒンメイ	NAME OF PARTS	RM
1	S51857101	1	Xオクリレバ-100クミ	X-FEED LEVER ASSY, 100	
1-1	S42067101	1	Xオクリレバ-100	X-FEED LEVER, 100	
1-2	S51858001	1	Xオクリレバ-フタ	X-FEED LEVER COVER	
1-3	153924001	1	フェルト	FELT	
1-4	108802001	1	クミヒモ4X4	WICK, 4X4 L=250	
1-5	S37932101	1	オクリカムコロ	FEED CAM ROLLER	
1-6	S37933001	1	コロシク	ROLLER SHAFT	
1-7	014760632	1	アナクホミ595-28X6	SET SCREW SOCKET SM5.95-28X6	
2	S37934101	1	Xオクリレバ-メタル	X-FEED LEVER BUSH	
3	183493001	1	オクリシクセツトカラ-クミ	F-SHAFT SET SCREW COLLAR ASSY	
3-1	S09212001	1	セツトカラ-	SET SCREW COLLAR	
3-2	101706001	2	トメネジ6.35	SET SCREW SM6.35	
4	153393001	1	ヨコオクリレバ-カンザ-	WASHER	
5	071047650	1	コウキユウ3/16	BEARING BALL, 3/16	
6	014760632	1	アナクホミ595-28X6	SET SCREW SOCKET SM5.95-28X6	
7	S42069001	1	Yオクリレバ-60クミ	Y-FEED LEVER ASSY, 60	
7-1	S42070001	1	Yオクリレバ-60	Y-FEED LEVER, 60	
7-2	S37932101	1	オクリカムコロ	FEED CAM ROLLER	
7-3	S37933001	1	コロシク	ROLLER SHAFT	
7-4	014760632	1	アナクホミ595-28X6	SET SCREW SOCKET SM5.95-28X6	
7-5	152973001	1	クミヒモ4X4	WICK, 4X4 L=170	
8	152760051	1	タテオクリレバ-シク	TACK WIDTH FEED LEVER SHAFT	
9	048180142	1	トメワシクヨウC18	RETAINING RING, EXTERNAL C18	
10	152756001	2	スラストサガネ18	WASHER, THRUST 18	
11	014760632	1	アナクホミ595-28X6	SET SCREW SOCKET SM5.95-28X6	
12	S41703000	1	PMブラケットX	PM BRACKET, X	
13	S53099001	1	オクリカムX100	X-FEED CAM, 100	
14	014760632	2	アナクホミ595-28X6	SET SCREW SOCKET SM5.95-28X6	
15	S41705001	1	カムシクX	CAM SHAFT, X	
16	070688850	3	タマシクウケ688ZZ	BALL BEARING RADIAL 688ZZ	
17	S51099000	1	PMブラケットY	PM BRACKET, Y	
18	S51100001	1	オクリカムブラケットY60	Y-FEED CAM BRACKET, 60	
19	S53100001	1	オクリカムY60	Y-FEED CAM, 60	
20	014760632	2	アナクホミ595-28X6	SET SCREW SOCKET SM5.95-28X6	
21	S51101001	1	カムシクY	CAM SHAFT, Y	
22	070688850	2	タマシクウケ688ZZNR	BALL BEARING, 688ZZNR	
23	S37940001	2	イチキメピン	POSITIONING PIN	
24	062681012	2	ナヘコ437-40X10	SCREW PAN SM4.37-40X10	
25	S51103001	1	セツトカラ-	SET SCREW COLLAR	
26	014760632	2	アナクホミ595-28X6	SET SCREW SOCKET SM5.95-28X6	
27	S37942100	4	カップリングハブ8	COUPLING HUB, 8	
28	S37944100	2	カップリングスパーサ	COUPLING SPACER	
29	014760632	8	アナクホミ595-28X6	SET SCREW SOCKET SM5.95-28X6	
30	S51462001	1	ケンテンドグX	HOME POSITION DOG, X	
31	S51463001	1	ケンテンドグY	HOME POSITION DOG, Y	
32	060680712	2	バインド437-40X7	SCREW, BIND SM4.37-40X7	
33	S53108001	1	Xセンサートリツケイタ	X-SENSOR SETTING PLATE	
34	018400632	1	アナホルト4X6	BOLT SOCKET M4X6	
35	025040232	1	ヒラサガネチユウ4	WASHER PLAIN M 4	
36	S53109001	1	Xセンサートリツケダイ	X-SENSOR SETTING BASE	
37	S51465001	1	Yセンサートリツケイタ	Y-SENSOR SETTING PLATE	
38	062680612	1	ナヘコ4.37-40X6	SCREW PAN SM4.37-40X6	
39	S51856001	1	オクリダイアンナイイタF	FEED BAR GUIDE PLATE,F	
40	145318001	4	シメネジ4.37	SCREW, SM4.37	
41	S42083001	1	オクリダイアンナイイタR	FEED BAR GUIDE PLATE,R	
42	145318001	2	シメネジ4.37	SCREW, SM4.37	
43	100032004	2	サラネジ4.37	SCREW, FLAT SM4.37-40X8	
44	S42084201	1	オクリダイクミ	FEED BAR ASSY	
44-1	156076101	1	オクリダイ	FEED BAR	
44-2	153377001	2	コロA3X17.8	ROLLER, A 3X17.8	

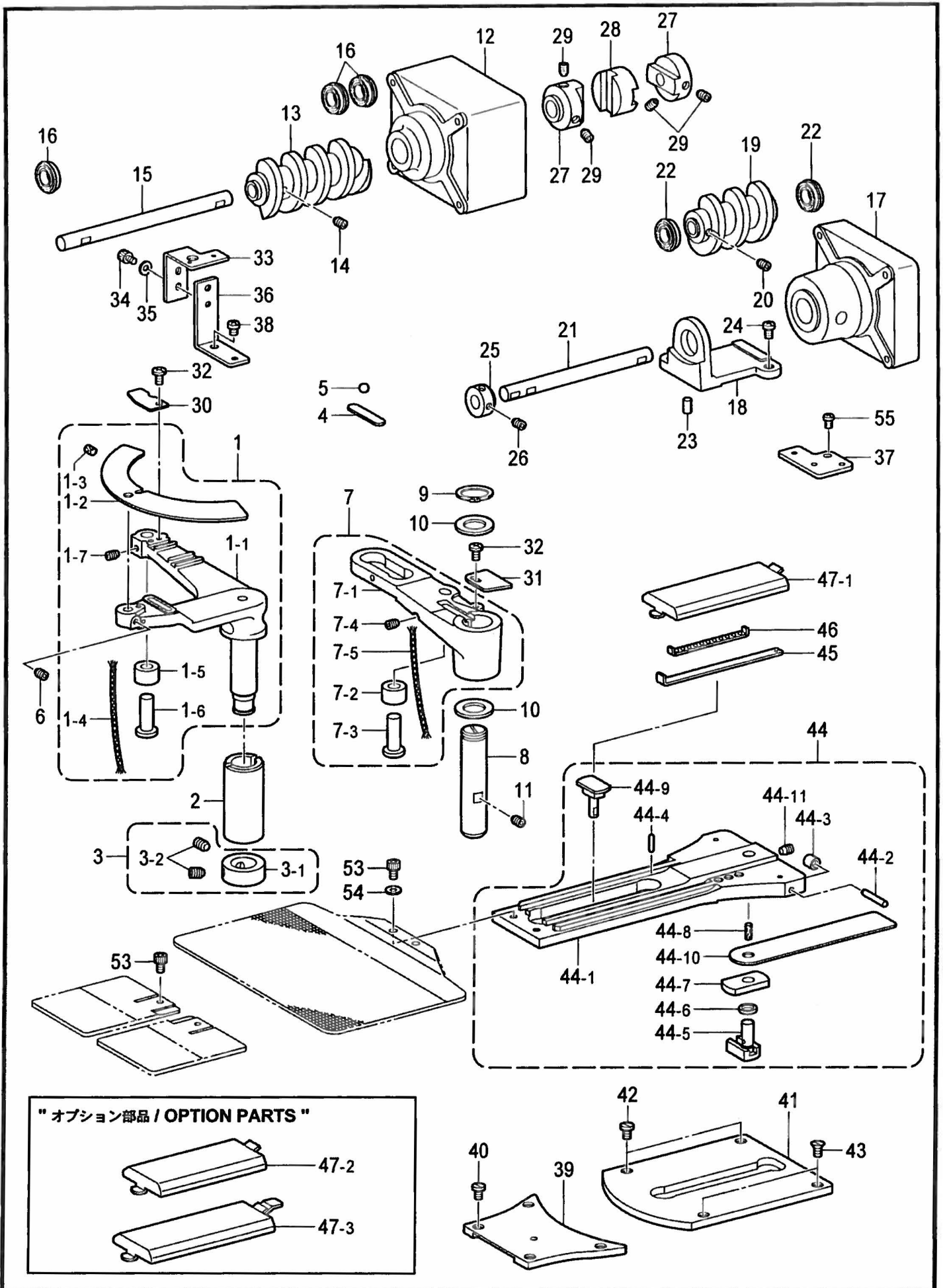

C1 . 送り関係 / Feed mechanism

REF.NO	CODE	Q'TY	ヒンメイ	NAME OF PARTS	RM
44-3	153378001	2	オクリダイコロ	FEED GUIDE ROLLER	
44-4	148133001	2	コロ	ROLLER	
44-5	156108001	1	タテオクリカクコマクミ	T-WIDTH REGULATOR BLOCK ASSY	
44-6	156109001	1	カンザ	SPACER	
44-7	156077001	1	オクリダイカクマ	FEED GUIDE SLIDE BLOCK	
44-8	156080000	1	フェルト	FELT	
44-9	153380001	1	ヨコオクリカクコマクミ	T-LENGTH REGULATOR BLOCK ASSY	
44-10	S42086101	1	Yオクリレバーフタ	Y-FEED LEVER COVER	
44-11	014760632	1	アナクホミ595-28X6	SET SCREW SOCKET SM5.95-28X6	
45	153383001	2	オクリダイカンザ	SPACER	
46	153384001	2	リテーナクミ	RETAINER ASSY	
47-1	153391001	1	オクリダイカバーL	FEED BRACKET COVER, L	
53	S59892001	4	アナホルト437-40X5	BOLT, SOCKET SM4.37-40X5	
54	025680232	2	ヒラザガネチユウ4.37	WASHER PLAIN M SM4.37	
55	062670612	1	ナベコ357-40X6	SCREW PAN SM3.57-40X6	
			" オプション部品 "	" OPTION PARTS "	
47-2	153392001	1	オクリダイカバーS	FEED BRACKET COVER, S	
47-3	S51860001	1	オクリダイカバーLLクミ	FEED BRACKET COVER ASSY, LL	

< 電磁式用 / For Solenoid type >

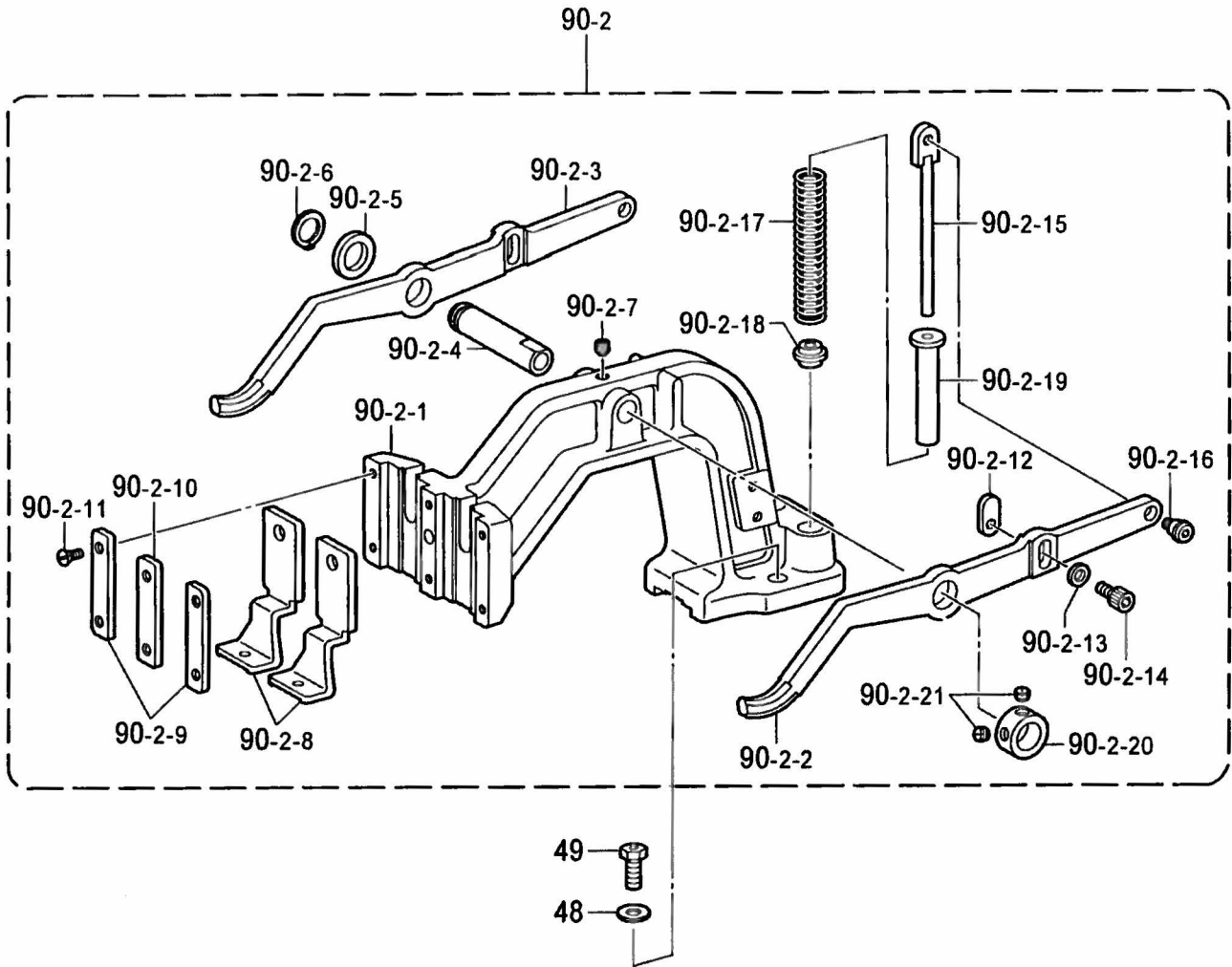

" オプション部品 / OPTION PARTS "

< 電磁式用 / For Solenoid type >

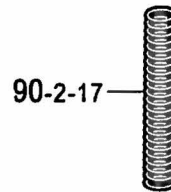
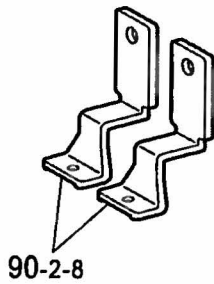

C2 . 送り関係 (電磁式用) / Feed mechanism (For Solenoid type)

REF.NO	CODE	Q'TY	ヒンメイ	NAME OF PARTS	RM
48	025060232	2	ヒラサガネチユ6	WASHER, PLAIN M 6	
49	S39110001	2	ボルト595-28X14	BOLT, W/SOCKET SM5.95-28X14	
			<中厚物用>	<For Medium-weight materials>	
90-2	S42090300	1	オサエウデクミLA	WORK CLAMP ARM ASSY, LA	
90-2-8	153372001	2	オサエアシL	WORK CLAMP, L	
90-2-17	153568001	2	オサエハネA	PRESSER SPRING, A	
			<厚物用>	<For Heavy-weight materials>	
90-2	S42092300	1	オサエウデクミLB	WORK CLAMP ARM ASSY, LB	
90-2-8	153372001	2	オサエアシL	WORK CLAMP, L	
90-2-17	153569001	2	オサエハネB	PRESSER SPRING, B	
90-2-1	153364000	1	オサエウデ	WORK CLAMP ARM	
90-2-2	S42088001	1	オサエウデレバーR	WORK CLAMP ARM LEVER, R	
90-2-3	S42089001	1	オサエウデレバーL	WORK CLAMP ARM LEVER, L	
90-2-4	153367001	1	オサエウデレバーシク	WORK CLAMP ARM LEVER SHAFT	
90-2-5	142628001	1	スイヘイオクリクランリング	SPACER	
90-2-6	048110142	1	トメワシクヨウC11	RETAINING RING, EXTERNAL C11	
90-2-7	152718001	1	アトメネシ5.95	SET SCREW, SOCKET SM5.95X5	
90-2-9	153369001	2	オサエアシオサエイタA	WORK CLAMP GUIDE PLATE, A	
90-2-10	153370001	1	オサエアシオサエイタB	WORK CLAMP GUIDE PLATE, B	
90-2-11	107038003	6	サラネシ3.57	SCREW, FLAT SM3.57	
90-2-12	S52099001	2	オサエウデレバーイタ	WORK CLAMP ARM LEVER PLATE	
90-2-13	140407002	2	サガネ	WASHER	
90-2-14	018500832	2	アナボルト5X8	BOLT, SOCKET M5X8	
90-2-15	159828101	2	オサエハネアンナイロツトB	SPRING GUIDE ROD, B	
90-2-16	145478101	2	ダンネシ4.76	SHOULDER SCREW, SOCKET SM4.76	
90-2-18	152788000	2	オサエハネカンサ	PRESSER SPRING SPACER	
90-2-19	153567000	2	オサエハネカラー	PRESSER SPRING COLLAR	
90-2-20	146581002	1	セツカラー	SET SCREW COLLAR	
90-2-21	100260001	2	トメネシ5.95	SET SCREW, SM5.95-28X4	
			" オプション部品 "	" OPTION PARTS "	
			<中厚物用>	<For Medium-weight materials>	
90-2	S42087300	1	オサエウデクミSA	WORK CLAMP ARM ASSY, SA	
90-2-8	153368001	2	オサエアシS	WORK CLAMP, S	
90-2-17	153568001	2	オサエハネA	PRESSER SPRING, A	
			<厚物用>	<For Heavy-weight materials>	
90-2	S42091300	1	オサエウデクミSB	WORK CLAMP ARM ASSY, SB	
90-2-8	153368001	2	オサエアシS	WORK CLAMP, S	
90-2-17	153569001	2	オサエハネB	PRESSER SPRING, B	

" オプション部品 / OPTION PARTS "

< 電磁式用 / For Solenoid type >

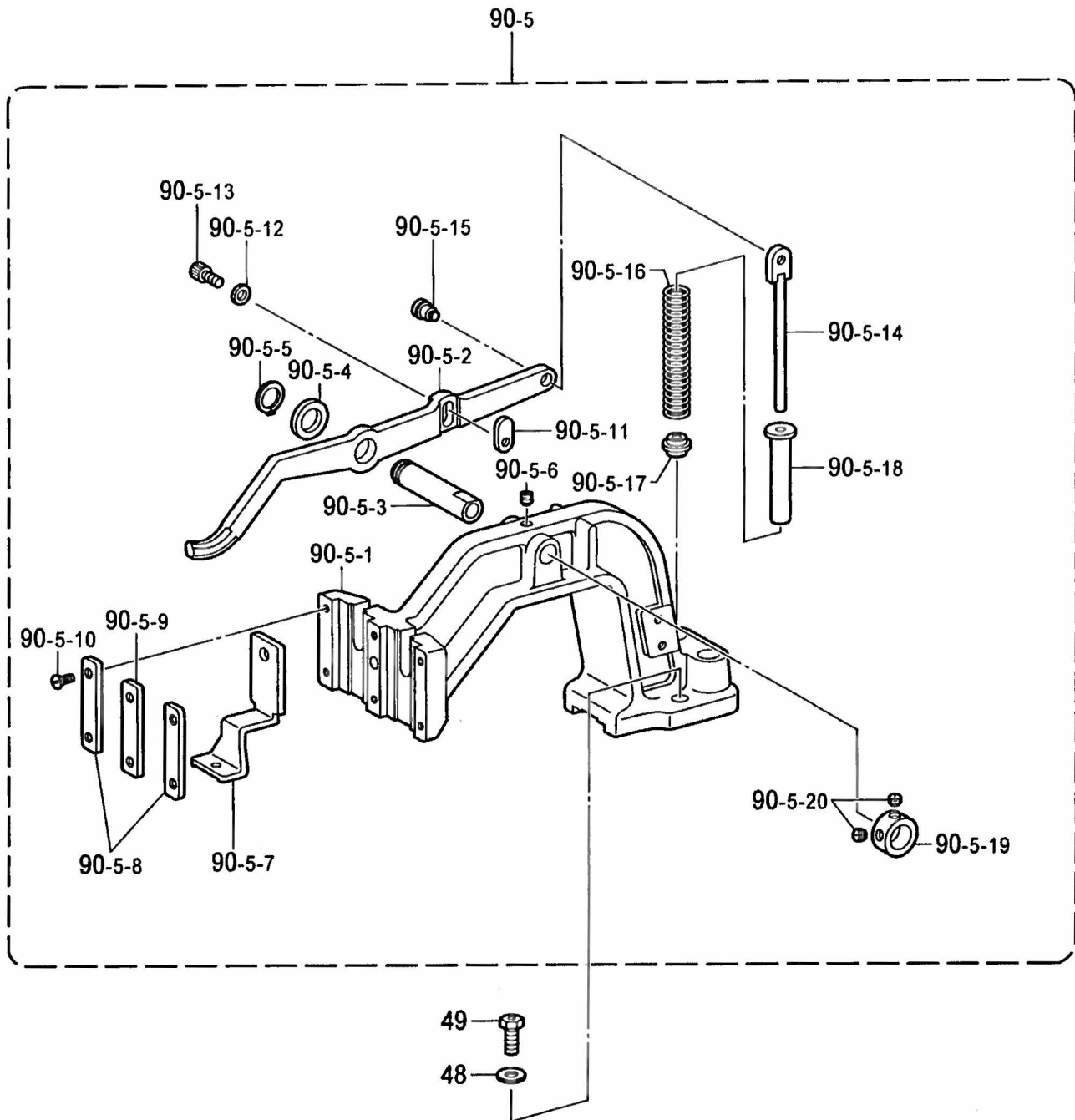

C3 . 送り関係 (電磁式用) / Feed mechanism (For Solenoid type)

REF.NO	CODE	Q'TY	ヒンメイ	NAME OF PARTS	RM
48	025060232	2	ヒラサガネチユウ6	WASHER, PLAIN M 6	
49	S39110001	2	ホルト595-28X14	BOLT, W/SOCKET SM5.95-28X14	
			" オプション部品 "	" OPTION PARTS "	
90-5	S42093300	1	オサエウデクミG	WORK CLAMP ARM ASSY, G	
90-5-1	153364000	1	オサエウデ	WORK CLAMP ARM	
90-5-2	S42089001	1	オサエウデレバーL	WORK CLAMP ARM LEVER, L	
90-5-3	153367001	1	オサエウデレバーシク	WORK CLAMP ARM LEVER SHAFT	
90-5-4	142628001	1	スィヘイオクリクランクリンク	SPACER	
90-5-5	048110142	1	トメウシクヨウC11	RETAINING RING, EXTERNAL C11	
90-5-6	152718001	1	アナトメネジ5.95	SET SCREW, SOCKET SM5.95X5	
90-5-7	154512001	1	オサエアシG	WORK CLAMP, G	
90-5-8	153369001	2	オサエアシオサエイタA	WORK CLAMP GUIDE PLATE, A	
90-5-9	153370001	1	オサエアシオサエイタB	WORK CLAMP GUIDE PLATE, B	
90-5-10	107038003	6	サラネジ3.57	SCREW, FLAT SM3.57	
90-5-11	S52099001	1	オサエウデレバーイタ	WORK CLAMP ARM LEVER PLATE	
90-5-12	140407002	1	サガネ	WASHER	
90-5-13	018500832	1	アナホルト5X8	BOLT, SOCKET M5X8	
90-5-14	159828101	1	オサエハネアンナイロツトB	SPRING GUIDE ROD, B	
90-5-15	145478101	1	ダンネジ4.76	SHOULDER SCREW, SOCKET SM4.76	
90-5-16	153568001	1	オサエハネA	PRESSER SPRING, A	
90-5-17	152788000	1	オサエハネカンサ	PRESSER SPRING SPACER	
90-5-18	153567000	1	オサエハネカラー	PRESSER SPRING COLLAR	
90-5-19	146581002	1	セットカラー	SET SCREW COLLAR	
90-5-20	100260001	2	トメネジ5.95	SET SCREW, SM5.95-28X4	

C4. 送り関係 (KE-434C, KE-435C エア一式用) /
 Feed mechanism (For Pneumatic type of KE-434C & KE435C)

< KE-434C, KE-435C エア一式用 / For Pneumatic type of KE-434C & KE-435C >

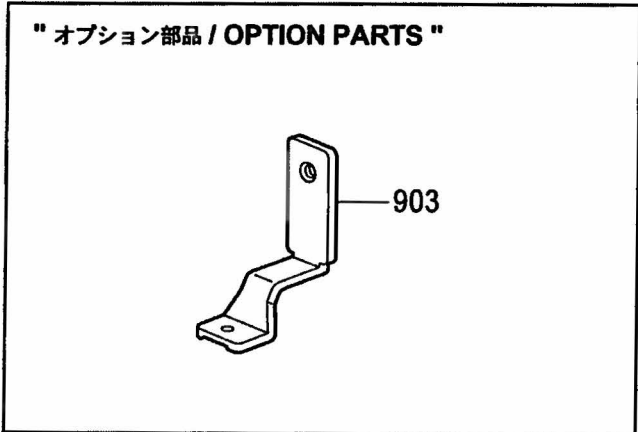
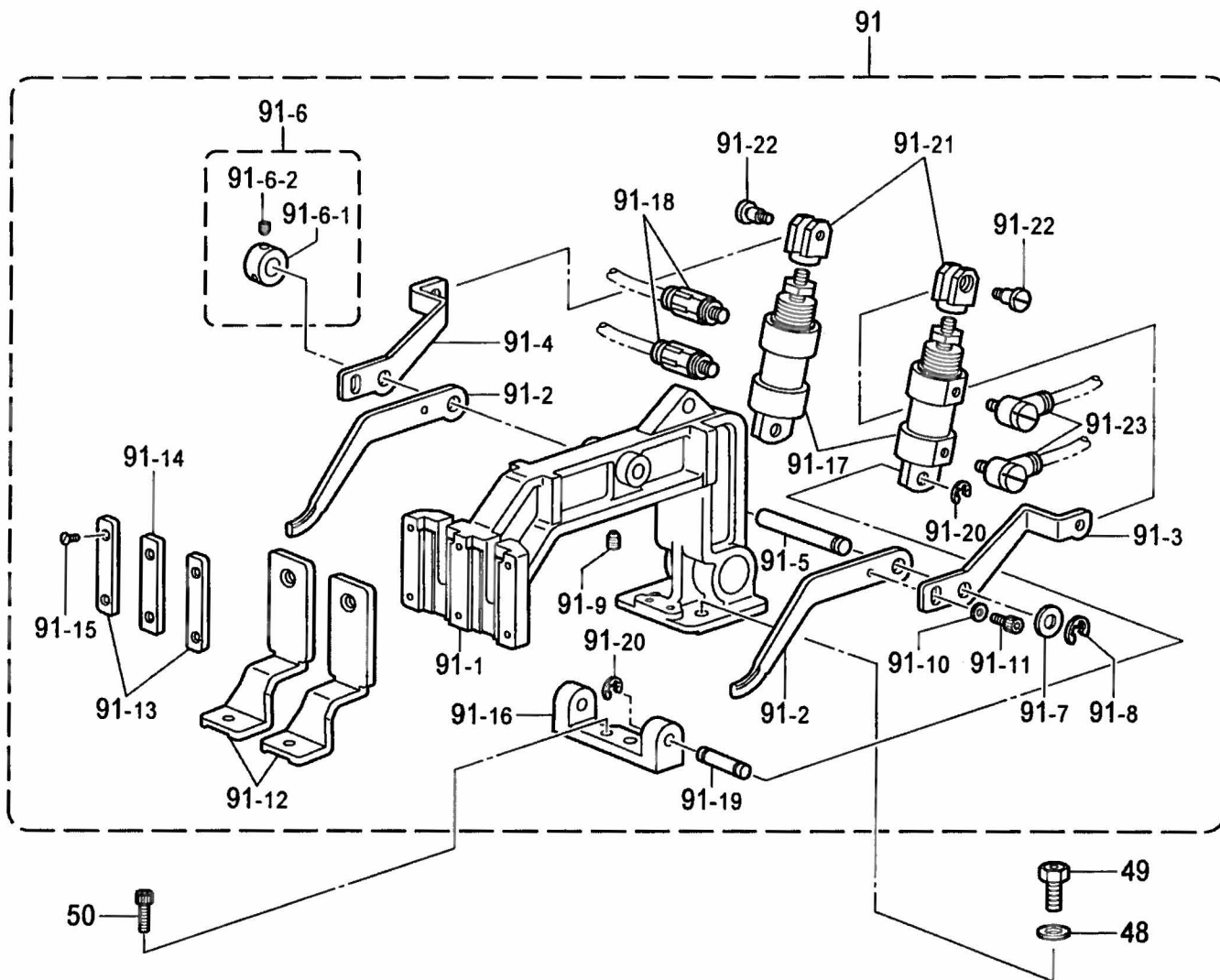

C4 . 送り関係 (KE-434C, KE-435Cエア一式用) /

Feed mechanism (For Pneumatic type of KE-434C & KE-435C)

REF.NO	CODE	Q'TY	ヒンメイ	NAME OF PARTS	RM
48	100197002	2	サガネ	WASHER	
49	S39110001	2	ホルト595-28X14	BOLT, W/SOCKET SM5.95-28X14	
50	018501032	2	アナホルト5X10	BOLT, SOCKET M5X10	
91	S53091001	1	オサエウテクミ434Eエア-	WORK CLAMP ARM ASSY, 434E PNEU	
91-1	S41658000	1	オサエウテZ34エア-	WORK CLAMP ARM, Z34 PNEUMATIC	
91-2	S53092001	2	オサエウテレバ-F	WORK CLAMP ARM LEVER, F	
91-3	S10377101	1	オサエウテレバ-RR	WORK CLAMP ARM LEVER, RR	
91-4	S10378101	1	オサエウテレバ-RL	WORK CLAMP ARM LEVER, RL	
91-5	S10058001	1	オサエウテレバ-ジク	W-CLAMP ARM LEVER SHAFT	
91-6	S21775001	1	セットカラークミ	SET SCREW COLLAR ASSY	
91-6-1	139096001	1	セットカラー	SET SCREW COLLAR	
91-6-2	014680422	2	アトメネジ4.37クホミ	SET SCREW, SOCKET (CP) SM4.37	
91-7	143591001	1	スラストリング	THRUST RING	
91-8	048050342	1	トメワE5	RETAINING RING, E5	
91-9	014760632	1	アナクホミ595-28X6	SET SCREW, SOCKET SM5.95-28X6	
91-10	025040232	2	ヒラサガネチユウ4	WASHER, PLAIN M 4	
91-11	018400632	2	アナホルト4X6	BOLT, SOCKET M4X6	
91-12	S41660001	2	オサエアシ434Eエア-	WORK CLAMP, 434E PNUMATIC	
91-13	153369001	2	オサエアシオサエイタA	WORK CLAMP GUIDE PLATE, A	
91-14	153370001	1	オサエアシオサエイタB	WORK CLAMP GUIDE PLATE, B	
91-15	107038003	6	サラネジ3.57	SCREW, FLAT SM3.57	
91-16	S53094001	1	シリンダササエ	CYLINDER SUPPORT	
91-17	S53095000	2	エアシリンダ15-18	AIR CYLINDER, 15-18	
91-18	S18415101	2	ハーフユニオンQ4M5	HALF UNION :Q4M5	
91-19	S03800001	2	クレビスピン	CLEVIS PIN	
91-20	048040342	4	トメワE4	RETAINING RING, E4	
91-21	S53096001	2	シリンダツギテ	CYLINDER JOINT	
91-22	110168001	2	コロシク	ROLLER SHAFT	
91-23	S41271000	2	エルボM5	ELBOW, M5	
903	S51102001	1	“ オプション部品 ” オサエアシ434EMK2エア-	“ OPTION PARTS ” WORK CLAMP, 434EMK2 AIR	

C5. 送り関係(KE-434C中押工反転装置用) /
 Feed mechanism (For Inner clamping device of KE-434C)

< KE-434C 中押工反転装置用 / For Inner clamping device of KE-434C >

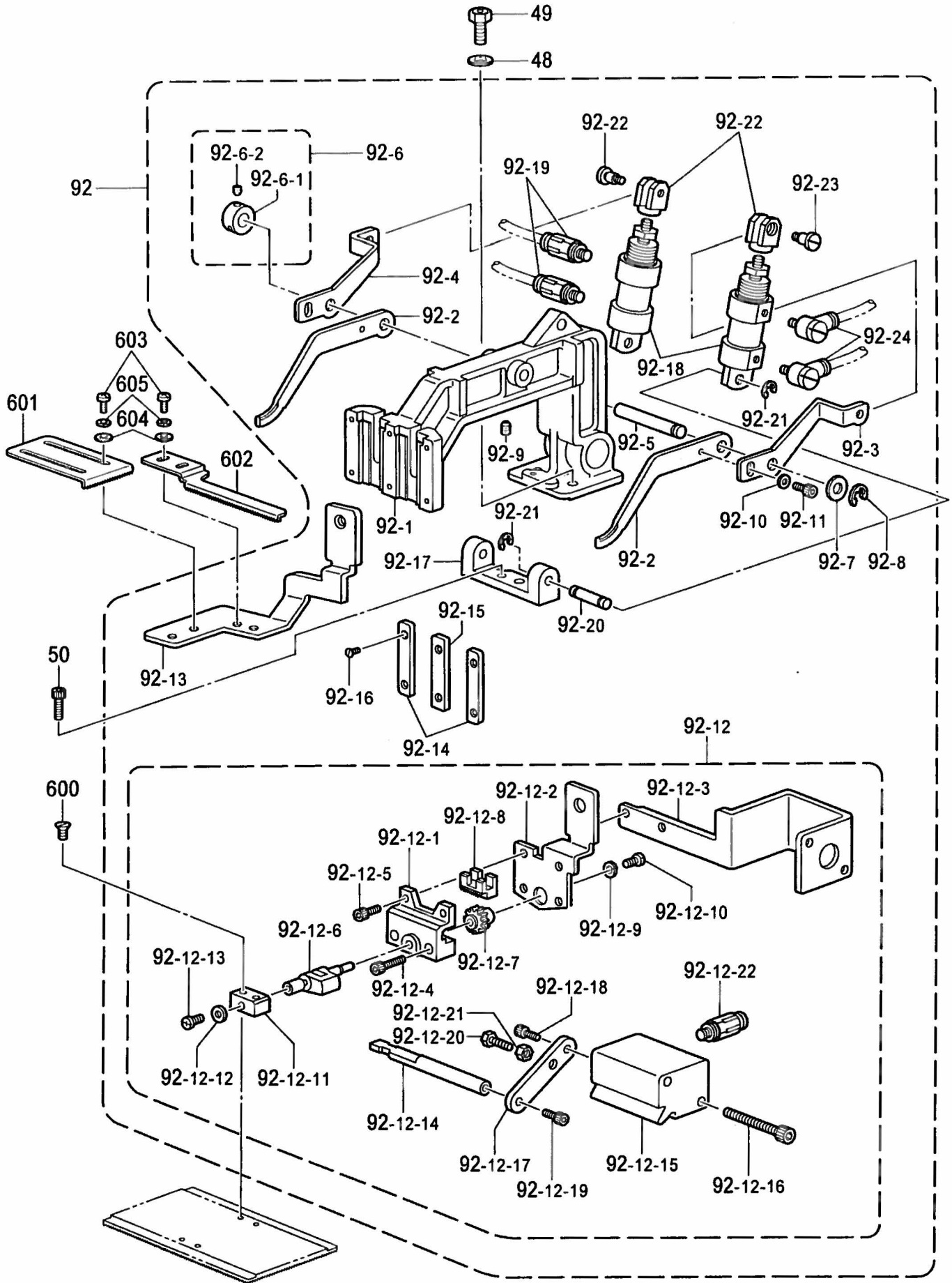

KE-434C/435C-202

C5 . 送り関係 (KE-434C中押工反転装置用) /

Feed mechanism (For Inner clamping device of KE-434C)

REF.NO	CODE	Q'TY	ヒンメイ	NAME OF PARTS	RM
48	100197002	2	サガネ	WASHER	
49	S39110001	2	ホルト595-28X14	BOLT, W/SOCKET SM5.95-28X14	
50	018501032	2	アナホルト5X10	BOLT, SOCKET M5X10	
92	S53098001	1	オサエウテクミ434EREV	WORK CLAMP ARM ASSY, 434E REV	
92-1	S41658000	1	オサエウテZ34エア-	WORK CLAMP ARM, Z34 PNEUMATIC	
92-2	S53092001	2	オサエウテレバ-F	WORK CLAMP ARM LEVER, F	
92-3	S10377101	1	オサエウテレバ-RR	WORK CLAMP ARM LEVER, RR	
92-4	S10378101	1	オサエウテレバ-RL	WORK CLAMP ARM LEVER, RL	
92-5	S10058001	1	オサエウテレバ-シク	W-CLAMP ARM LEVER SHAFT	
92-6	S21775001	1	セツカラークミ	SET SCREW COLLAR ASSY	
92-6-1	139096001	1	セツカラー	SET SCREW COLLAR	
92-6-2	014680422	2	アナムネシ4.37クホミ	SET SCREW, SOCKET (CP) SM4.37	
92-7	143591001	1	スラストリング	THRUST RING	
92-8	048050342	1	トメワE5	RETAINING RING, E5	
92-9	014760632	1	アナムホミ595-28X6	SET SCREW, SOCKET SM5.95-28X6	
92-10	025040232	2	ヒラサガネチユウ4	WASHER, PLAIN M 4	
92-11	018400632	2	アナホルト4X6	BOLT, SOCKET M4X6	
92-12	S42007001	1	オサエクランククミ434E	WORK CLAMP CRANK ASSY, 434E	
92-12-1	S12634009	1	オサエクランクホルダA	WORK CLAMP CRANK HOLDER, A	
92-12-2	S42008001	1	オサエクランクホルダB	WORK CLAMP CRANK HOLDER, B	
92-12-3	S42019001	1	ハンテシリンダ-ダイ	REVERSE CYLINDER BASE	
92-12-4	018301236	2	アナホルト3X12	BOLT, SOCKET M3X12	
92-12-5	018300836	2	アナホルト3X8	BOLT, SOCKET M3X8	
92-12-6	S05665001	1	オサエクランクLA	WORK CLAMP CRANK, LA	
92-12-7	154235001	1	ハンテッキヤ	REVERSE GEAR	
92-12-8	154236001	1	ハンテラツク	REVERSE RACK	
92-12-9	145087001	1	ハンテッキヤサガネ	WASHER	
92-12-10	149831101	1	アタマツキメネシ3.18	SET SCREW, SM3.18	
92-12-11	154237001	1	オサエイタホルダL	WORK CLAMP PLATE HOLDER, L	
92-12-12	025350132	1	ヒラサガネシヨウ	WASHER, PLAIN S 3.5	
92-12-13	100242003	1	シメネシ3.57	SCREW, SM3.57-40X5	
92-12-14	S42020001	1	ハンテロツト	REVERSE ROD	
92-12-15	S12639001	1	ハンテシリンダ	REVERSE CYLINDER	
92-12-16	S12642009	2	アナホルト3X35	BOLT, SOCKET M3X35	
92-12-17	S42021001	1	ハンテシクツキテ	REVERSE SHAFT JOINT	
92-12-18	018300836	1	アナホルト3X8	BOLT, SOCKET M3X8	
92-12-19	018300836	1	アナホルト3X8	BOLT, SOCKET M3X8	
92-12-20	017501216	1	ホルト5X12	BOLT, M5X12	
92-12-21	021500216	1	2シユナツト5	NUT, 2 M5	
92-12-22	S18415101	2	ハーフユニオンQ4M5	HALF UNION :Q4M5	
92-13	S42009101	1	ソトオサエアシナミ	OUTER WORK CLAMP	
92-14	153369001	2	オサエアシオサエイタA	WORK CLAMP GUIDE PLATE, A	
92-15	153370001	1	オサエアシオサエイタB	WORK CLAMP GUIDE PLATE, B	
92-16	107038003	6	サラネシ3.57	SCREW, FLAT SM3.57	
92-17	S53094001	1	シリンダササエ	CYLINDER SUPPORT	
92-18	S53095000	2	エアシリンダ15-18	AIR CYLINDER, 15-18	
92-19	S18415101	2	ハーフユニオンQ4M5	HALF UNION :Q4M5	
92-20	S03800001	2	クレビスピン	CLEVIS PIN	
92-21	048040342	4	トメワE4	RETAINING RING, E4	
92-22	S53096001	2	シリンダツキテ	CYLINDER JOINT	
92-23	110168001	2	コロシク	ROLLER SHAFT	
92-24	S41271000	2	エルホM5	ELBOW, M5	
600	117291002	2	サラネシ3.18	SCREW, FLAT SM3.18	
601	154252001	1	イチキメイタL	POSITIONING PLATE, L	
602	154253001	1	イチキメイタR	POSITIONING PLATE, R	
603	062670512	4	ナヘコ357-40X5	SCREW, PAN SM3.57-40X5	
604	025350332	4	ヒラサガネダイ3.5	WASHER, PLAIN L 3.5	
605	028350242	4	ハネサガネ2-3.5	WASHER, SPRING 2-3.5	

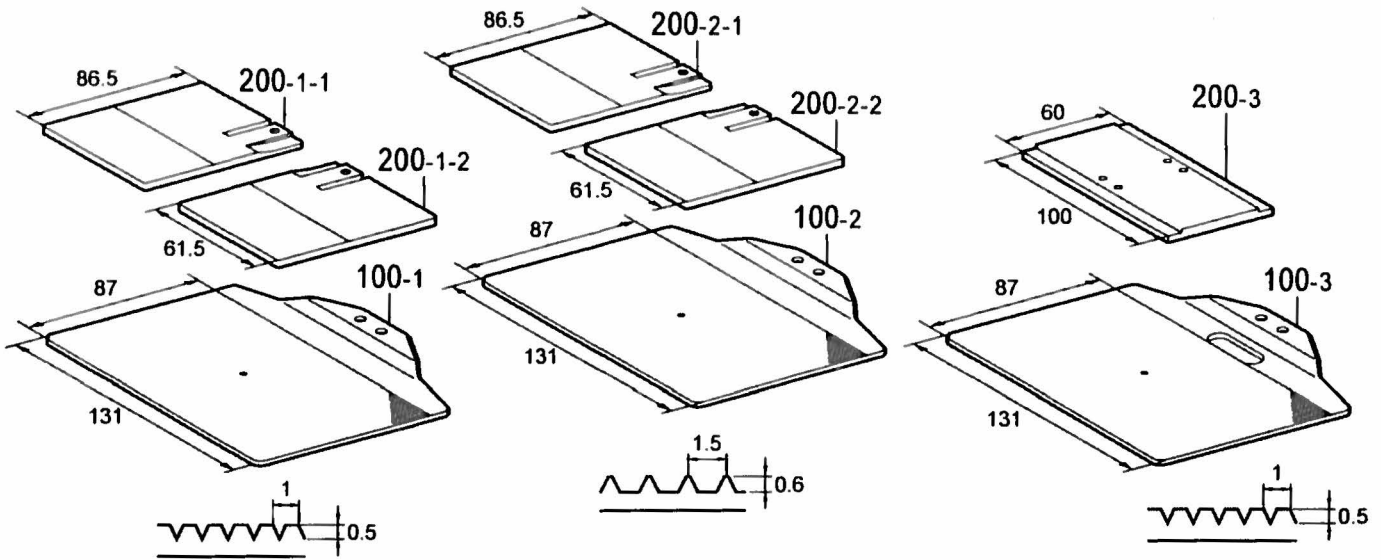

< ゲージ部品 / Gauge parts >

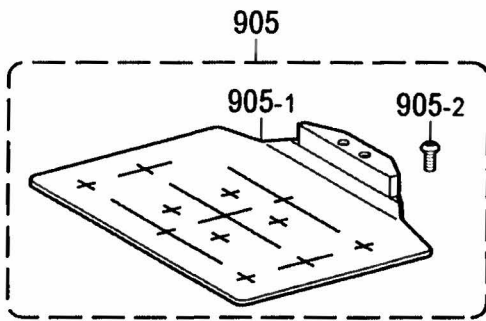

< KE-435C用 / For KE-435C >

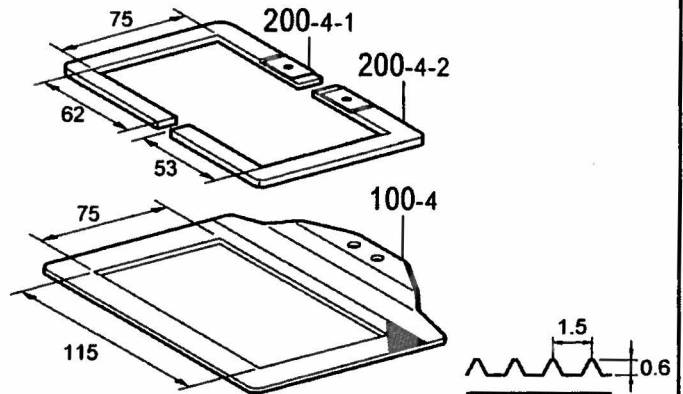

" オプション部品 / OPTION PARTS " < 電磁式用 / For solenoid type >

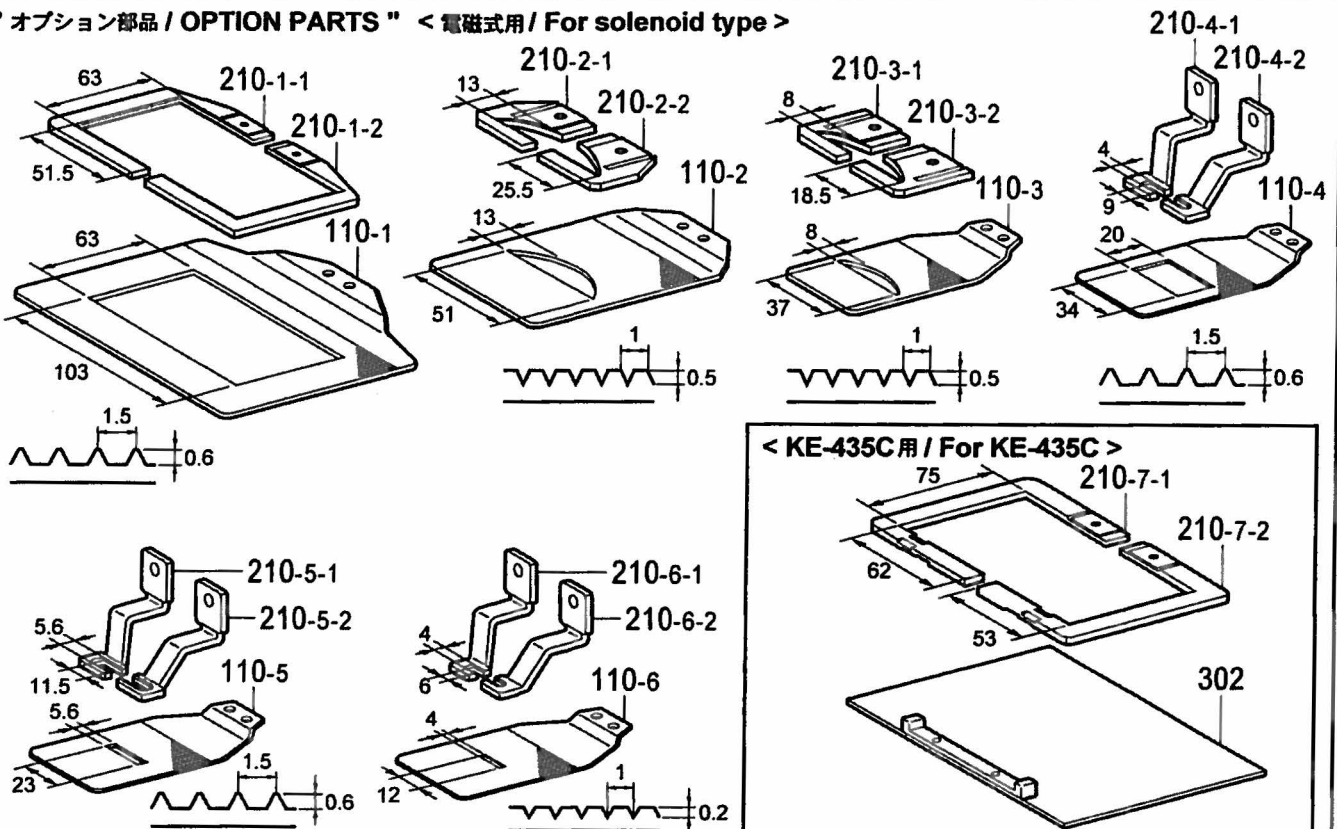

C6 . 送り関係 / Feed mechanism

REF.NO	CODE	QTY	ヒンメイ	NAME OF PARTS	RM
			" ブランク材 "	" BLANK "	
			< 中厚物用 >	< For Medium-weight materials >	
100-1	S42034001	1	オクリイタブランク434-1	FEED PLATE BLANK, 434-1	
200-1-1	S42031001	1	オサエブランク434-1L	WORK CLAMP BLANK, 434-1L	
200-1-2	S42030001	1	オサエブランク434-1R	WORK CLAMP BLANK, 434-1R	
			< 厚物用 >	< For Heavy-weight materials >	
100-2	S42035001	1	オクリイタブランク434-2	FEED PLATE BLANK, 434-2	
200-2-1	S42033001	1	オサエブランク434-2L	WORK CLAMP BLANK, 434-2L	
200-2-2	S42032001	1	オサエブランク434-2R	WORK CLAMP BLANK, 434-2R	
			< 反転用 >	< For Inner clamping device >	
100-3	S43459001	1	オクリイタブランク434R1	FEED PLATE BLANK, 434R1	
200-3	154256101	1	オサエイタブランクA	WORK CLAMP PLATE BLANK, A	
			< KE-435C用 >	< For KE-435C >	
100-4	S44942001	1	オクリイタ434ESF-2	FEED PLATE, 434ESF-2	
200-4-1	S46545001	1	オサエヒタリ434ESF-2	WORK CLAMP, LEFT 434ESF-2	
200-4-2	S46544001	1	オサエミキ434ESF-2	WORK CLAMP, RIGHT 434ESF-2	
			" オプション部品 "	" OPTION PARTS "	
			[電磁式用]	[For solenoid type]	
			< 100X60用 >	< For "100X60" >	
110-1	153503001	1	オクリイタ	FEED PLATE	
210-1-1	153498001	1	オサエヒタリ	WORK CLAMP, LEFT 100X60	
210-1-2	153493001	1	オサエミキ	WORK CLAMP, R	
			< 48X10XR30用 >	< For "48X10XR30" >	
110-2	S23379001	1	オクリイタ434-519	FEED PLATE, 434-519	
210-2-1	S23378001	1	オサエヒタリ434-519	WORK CLAMP, LEFT 434-519	
210-2-2	S23377001	1	オサエミキ434-519	WORK CLAMP, RIGHT 434-519	
			< 34X5XR28用 >	< For "34X5XR28" >	
110-3	S27838001	1	オクリイタ434-895	FEED PLATE, 434-895	
210-3-1	S27837001	1	オサエヒタリ434-895	WORK CLAMP, LEFT 434-895	
210-3-2	S27836001	1	オサエミキ434-895	WORK CLAMP, 434-895	
			< 罫止縫い16X2用 >	< For Sewing the bar tack "16X2" >	
110-4	156087001	1	オクリイタ	FEED PLATE	
210-4-1	156086001	1	オサエアシLM	WORK CLAMP, LM	
210-4-2	156085001	1	オサエアシRM	WORK CLAMP, RM	
			< 罫止縫い20X3用 >	< For Sewing the bar tack "20X3" >	
110-5	156084001	1	オクリイタL	FEED PLATE, L	
210-5-1	156083001	1	オサエアシLL	WORK CLAMP, LL 20X3	
210-5-2	156082001	1	オサエアシRL	WORK CLAMP, RL 20X3	
			< 罫止縫い10X2用 >	< For Sewing the bar tack "10X2" >	
110-6	156090001	1	オクリイタS	FEED PLATE, S	
210-6-1	156089001	1	オサエアシLS	WORK CLAMP, LS 10X2	
210-6-2	156088001	1	オサエアシRS	WORK CLAMP, RS 10X2	
			[KE-435C用]	[For KE-435C]	
			< ワンタッチ押工用 >	< For One-touch work clamp >	
210-7-1	S44941001	1	オサエヒタリ434ESF	WORK CLAMP, LEFT 434ESF	
210-7-2	S44940001	1	オサエミキ434ESF	WORK CLAMP, RIGHT 434ESF	
			< ワンタッチ押工組 >	< One-touch work clamp assy >	
302	S43990001	1	OTオサエイタ434EAクミ <t=0.5>	OT WORK CLAMP ASSY, A 434E <t=0.5>	
302	S43991001	1	OTオサエイタ434EBクミ <t=1.0>	OT WORK CLAMP ASSY, B 434E <t=1.0>	
302	S43992001	1	OTオサエイタ434ECクミ <t=2.0>	OT WORK CLAMP ASSY, C 434E <t=2.0>	
			< ゲージ部品 >	< Gauge parts >	
905	S54984001	1	ゲージクミ434EMK2	GAUGE ASSY, 434EMK2	
905-1	S52100001	1	ゲンテンキジユニタ	HOME POSITION STANDARD PLATE	
905-2	S49955001	2	オクリイタシメネジ	SCREW, W/SOCKET SM4.37	

< KE-434C 電磁式用 / For Solenoid type of KE-434C >

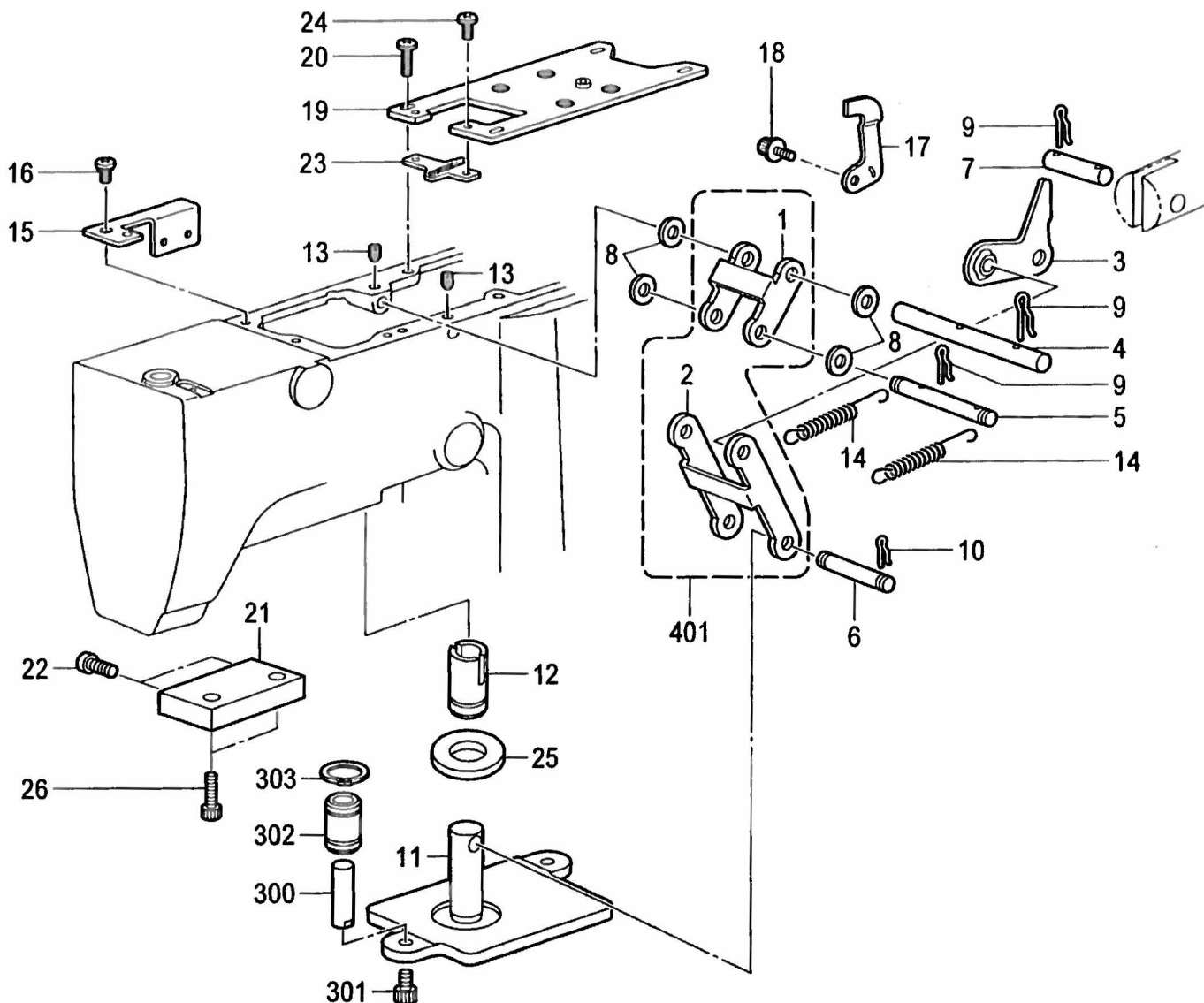

< KE-434Cエア一式用, KE-434C中押工反転装置用
/ For Pneumatic type of KE-434C
& Inner clamping device of KE-434C >

< KE-435Cエア一式用 / For Pneumatic type of KE-435C >

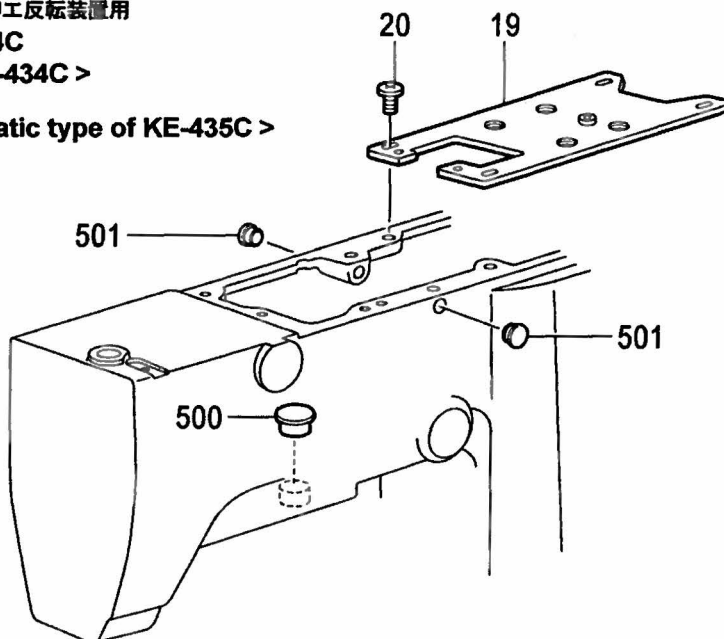

D1 . 押エ上げ関係 / Work clamp lifter mechanism

REF.NO	CODE	Q'TY	ヒンメイ	NAME OF PARTS	RM
			<KE-434C電磁式用>	<For Solenoid type of KE-434C>	
401	SA4141001	1	リンクミAB	LINK ASSY, AB	
1	S49630001	1	リンクA	LINK, A	
2	S49631001	1	リンクB	LINK, B	
3	S49632001	1	リンクCミ	LINK ASSY, C	
4	S49635001	1	リンクジクA	LINK SHAFT, A	
5	S49636001	1	リンクジクB	LINK SHAFT, B	
6	S49637001	1	リンクジクC	LINK SHAFT, C	
7	S49638001	1	リンクジクD	LINK SHAFT, D	
8	100281001	4	ザガネ	WASHER, PLAIN	
9	S37968001	6	スナツプピン8	SNAP PIN, 8	
10	S19662001	2	スナツプピン5	SNAP PIN, 5	
11	S41238001	1	オサエイタL	WORK CLAMP PLATE, L	
12	S55157000	1	オサエイタヨウメタル	BUSH	
13	014760632	2	アナクホミ5.95-28X6	SET SCREW SOCKET SM5.95-28X6	
14	S10105001	2	リンクモシバネ	SPRING, EXTENSION	
15	S49639001	1	センサトリツケタイ	SENSOR SETTING BASE	
16	062680612	1	ナベコ4.37-40X6	SCREW PAN SM4.37-40X6	
17	S49640101	1	センサカンチイタ	SENSOR PERCEIVE PLATE	
18	S55479001	1	アナホルツサクミ4X8	BOLT, SOCKET (S/P WASHER) M4X8	
19	S49641001	1	ソレノイドトリツケイタA	SOLENOID SETTING PLATE, A	
20	060681212	4	バインド437-40X12	SCREW BIND SM4.37-40X12	
21	S49642001	1	ソレノイドトリツケイタB	SOLENOID SETTING PLATE, B	
22	060501016	2	バインドM5X10	SCREW BIND M5X10	
23	S49643001	1	ガイド	GUIDE	
24	060680712	2	バインド437-40X7	SCREW, BIND SM4.37-40X7	
25	S59763000	1	オサエアケストツパゴム	W-CLAMP LIFTER STOPPER RUBBER	
26	018501432	2	アナホルツ5X14	BOLT SOCKET M5X14	
300	S41239001	2	アンナイシク12	GUIDE SHAFT, 12	
301	018501036	2	アナホルツ5X10	BOLT SOCKET M5X10	
302	S10103001	2	ボールブツシユ	BALL BUSH	
303	048200142	2	トメワシクヨウC20	RETAINING RING EXTERNAL C20	
			<KE-434Cエア一式用 KE-434C中押エ反転装置用>	<For Pneumatic type of KE-434C & Inner clamping device of KE-434C>	
			<KE-435Cエア一式用>	<For Pneumatic type of KE-435C>	
19	S49641001	1	ソレノイドトリツケイタA	SOLENOID SETTING PLATE, A	
20	060681212	4	バインド437-40X12	SCREW, BIND SM4.37-40X12	
500	S10125000	3	ゴムセン21	RUBBER CAP, 21	
501	104450101	2	ゴムセン8	RUBBER CAP, 8	

< KE-435C 用 / For KE-435C >

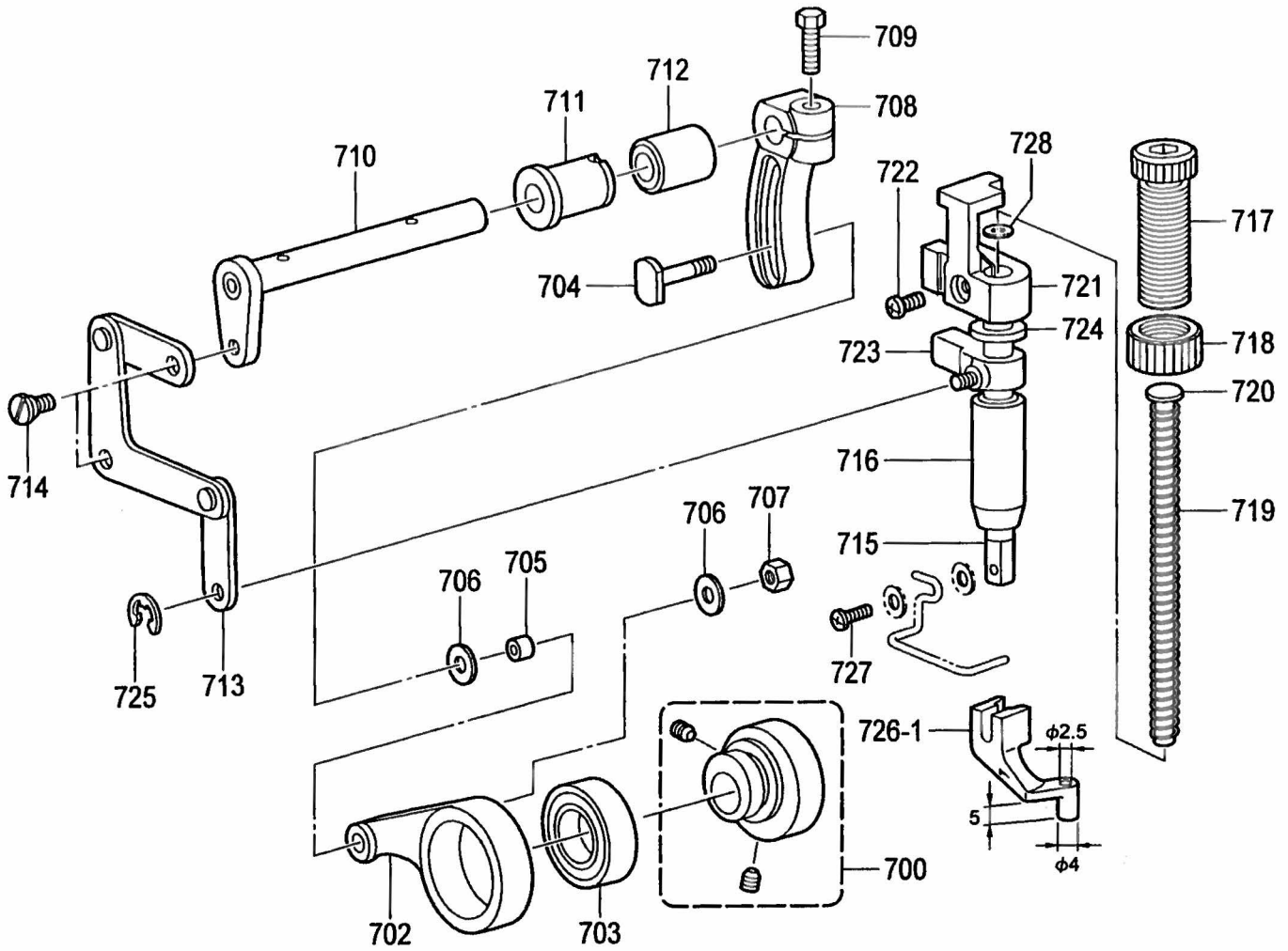

" オプション部品 / OPTION PARTS "

726-2

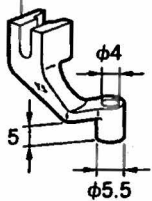

726-3

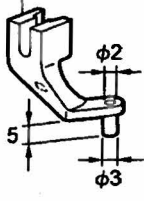

726-6

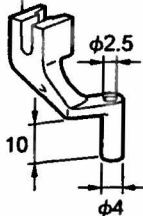

726-4

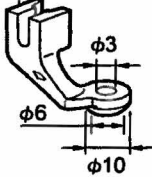

726-5

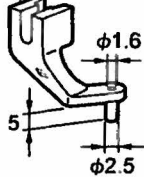

< 補給用部品 / For supply parts >

790



D2 . 押工上げ関係 (KE-435C) / Work clamp lifter mechanism (KE-435C)

REF.NO	CODE	Q'TY	ヒンメイ	NAME OF PARTS	RM
			<KE-435C用>	<For KE-434C>	
700	S59103001	1	カンケツオサエカムBクミ	STEPPING W-CLAMP CAM ASSY, B	
702	S43693000	1	カンケツオサエレンカン	STEPPING WORK CLAMP CON. ROD	
703	623033000	1	タマシクウケ6805VV	BALL BEARING, 6805VV	
704	150460001	1	U-UDオクリレバーシク	U-UD FEED LIFTER LEVER SHAFT	
705	150461001	1	オクリコロ	FEED ROLLER	
706	107453001	2	サガネ	WASHER	
707	021750102	1	1シユナツト556-32	NUT, 1 SM5.56-32	
708	S17871101	1	カンケツオサエウテR	STEPPING WORK CLAMP ARM, R	
709	017751412	1	ホルト5.56X14	BOLT, SM5.56X14	
710	S42839101	1	カンケツオサエウテF	STEPPING WORK CLAMP ARM, F	
711	148196000	1	ウワメサトウウテメタルL	BUSH, L	
712	148197000	1	ウワメサトウウテメタルR	BUSH, R	
713	S55144001	1	カンケツリンククミ	STEPPING W-CLAMP LIMK ASSY	
714	S54393001	2	ダンネシ5.56	SHOULDER SCREW, SM5.56	
715	S42880001	1	オサエホウウコ	PRESSER BAR, SIDE	
716	145472001	1	オサエホウメタル	PRESSER BAR BUSH	
717	S31012001	1	オサエチヨウセツネジ	PRESSER ADJUSTING SCREW	
718	S31013001	1	チヨウセツネジツマミナツト	PRESSER ADJUSTING NUT	
719	S10111101	1	オサエハネ	PRESSER BAR SPRING	
720	S10112001	1	オサエハネアンナイ	SPRING GUIDE	
721	S10113301	1	オサエホウダキ	P-BAR CLAMP	
722	062681212	1	ナヘコ437-40X12	SCREW, PAN SM4.37-40X12	
723	S10371001	1	オサエホウリフター	PRESSER BAR LIFTER	
724	S10372100	1	オサエホウダキクツシヨソ	CUSHION	
725	048040342	1	トメワE4	RETAINING RING, E4	
726-1	S42849101	1	オサエアシXA	WORK CLAMP, XA	
727	S13399001	1	シメネシ3.57X12	SCREW, SM3.57X12	
728	S03677001	1	サガネ	WASHER	
			" オプション部品 "	" OPTION PARTS "	
726-2	S45131001	1	オサエアシXB	WORK CLAMP, XB	
726-3	S45132001	1	オサエアシXC	WORK CLAMP, XC	
726-4	S45133001	1	オサエアシXD	WORK CLAMP, XD	
726-5	S45134001	1	オサエアシXE	WORK CLAMP, XE	
726-6	S45135001	1	オサエアシXJ	WORK CLAMP, XJ	
			" 補給用部品 "	" For Supply parts "	
790	S33251001	1	オサエハネ	PRESSER BAR SPRING	

E. 下軸関係 / Lower shaft mechanism

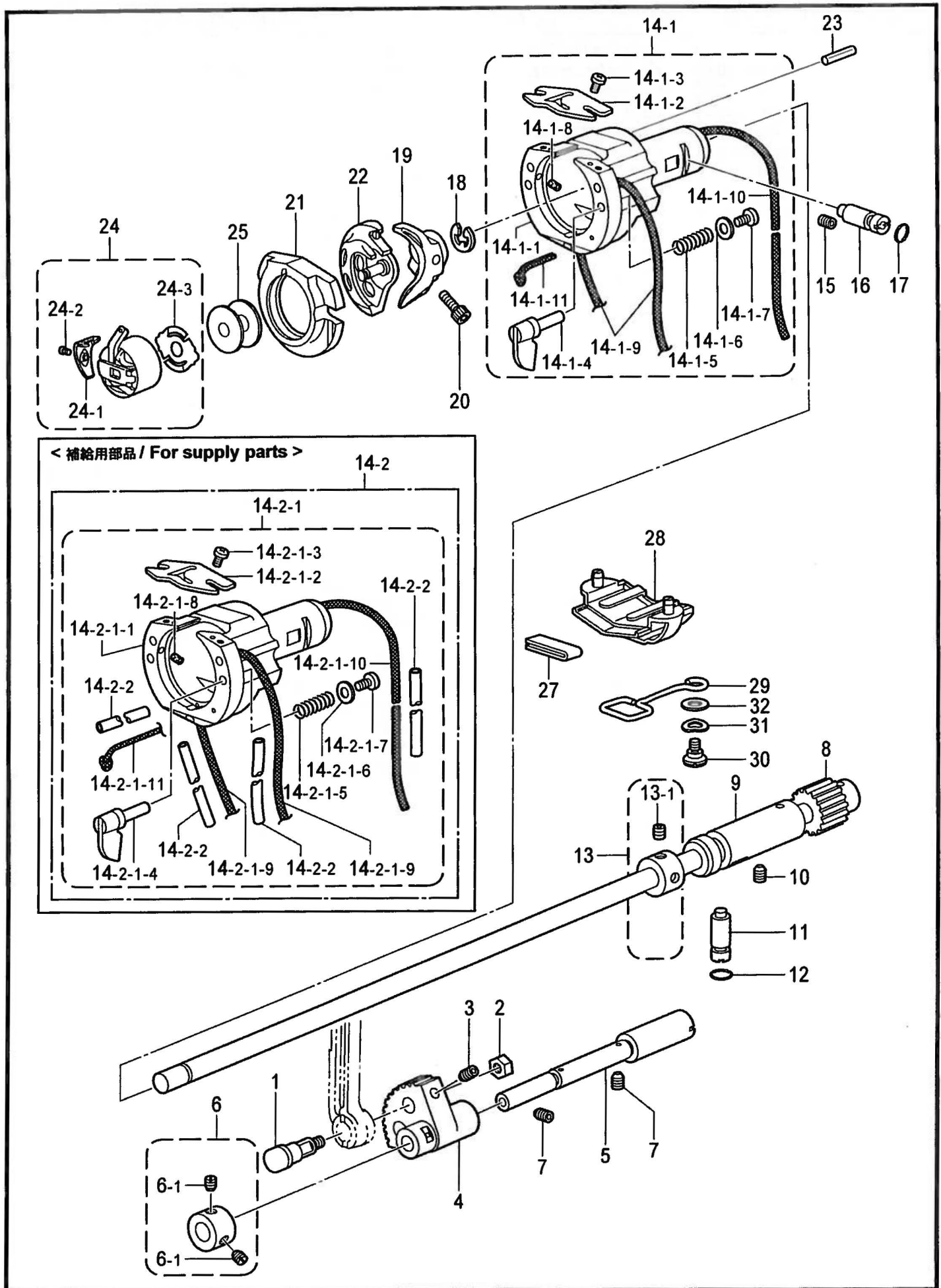

E . 下軸関係 / Lower shaft mechanism

REF.NO	CODE	Q'TY	ヒンメイ	NAME OF PARTS	RM
1	141786001	1	クランクアウトダンネジ	SHOULDER SCREW	
2	100090004	1	ナット7.14	NUT, SM7.14	
3	014680632	1	アナトクホミ437-40X6	SET SCREW SOCKET SM4.37-40X6	
4	152245101	1	ヨウトウキヤ	ROCK GEAR	
5	S37978251	1	ヨウトウキヤシク	ROCK GEAR SHAFT	
6	181995001	1	セツカラークミ	SET SCREW COLLAR ASSY	
6-1	101706001	2	トメネジ6.35	SET SCREW, SM6.35-40X5.5	
7	014760632	2	アナトクホミ595-28X6	SET SCREW SOCKET SM5.95-28X6	
8	S49605001	1	シタシククミ	LOWER SHAFT ASSY	
9	S55213001	1	シタシクメタル	LOWER SHAFT BUSH	
10	014760632	1	アナトクホミ595-28X6	SET SCREW SOCKET SM5.95-28X6	
11	152678201	1	カマチヨウセツジク	ADJUSTING STUD	
12	081003670	1	OリングPW3	O-RING, PW3	
13	S49609001	1	セツカラークミ	SET SCREW COLLAR ASSY	
13-1	014770632	2	アナトクホミ637-40X6	SET SCREW SOCKET SM6.37-40X6	
14-1	S55927301	1	オオカマタイクミ	SHUTTLE RACE BASE ASSY	
14-1-1	S55216301	1	オオカマタイ	SHUTTLE RACE BASE	
14-1-2	S02429201	1	カマイトアンナイ	SHUTTLE RACE THREAD GUIDE	
14-1-3	062660412	2	ナベコ318-40X4	SCREW PAN SM3.18-40X4	
14-1-4	152683101	2	オオカマトリツケツメ	S-RACE BASE SETTING CLAW	
14-1-5	152684101	2	オオカマトリツケバネ	COMPRESSION SPRING	
14-1-6	402887001	2	ザカネ3.2	WASHER, 3.2	
14-1-7	062660712	2	ナベコ318-40X7	SCREW, PAN SM3.18-40X7	
14-1-8	153050000	2	オオカマタイフェルト	S-RACE BASE FELT	
14-1-9	S59886001	2	クミヒモ3X3	WICK, 3X3 L=360	
14-1-10	S49626000	1	クミヒモ3X3	WICK, 3X3 L=300	
14-1-11	S49685000	1	クミヒモ3X3	WICK, 3X3 L=100	
15	014760622	1	アナトクホミ437-40X6	SET SCREW SOCKET SM4.37-40X6	
16	152678201	1	カマチヨウセツジク	ADJUSTING STUD	
17	081003670	1	OリングPW3	O-RING, PW3	
18	048070342	1	トメE7	RETAINING RING, E7	
19	S55215001	1	ドライバ-HR	DRIVER, HR	
20	018501232	1	アナホルト5X12	BOLT, SOCKET M5X12	
21	*	1	オオカマ	SHUTTLE RACE BASE	
22	*	1	ナカカマハコクミ	SHUTTLE HOOK ASSY, W/BOX	
23	S16290001	1	ニートルローラー4X19.8	NEEDLE ROLLER, 4X19.8	
24	*	1	ホビンケースクミA	BOBBIN CASE ASSY, A	
24-1	*	1	ホビンケースチヨウシバネ	TENSION SPRING	
24-2	*	1	ホビンケースバネネジ	SCREW	
24-3	*	1	クウデンホウシバネ	ANTI-SPIN SPRING	
25	*	1	ホビン	BOBBIN	
27	S55658000	1	カマフェルト	FELT	
28	S55214000	1	カマフェルトササエ	FELT HOLDER	
29	S55140001	1	サポート	SUPPORT	
30	123882001	1	ダンネジ4.37	STUD SCREW 4.37	
31	103810002	1	ナミカタハネザカネ	WAVE WASHER	
32	025770232	1	ヒラザカネチユウ6.35	WASHER, PLAIN M 6.35	
			" 補給用部品 "	" For Supply parts "	
14-2	S59888201	1	オオカマタイクミセット	SHUTTLE RACE BASE SET	
14-2-1	S59885001	1	オオカマタイクミ	SHUTTLE RACE BASE ASSY	
14-2-1-1	S55216001	1	オオカマタイ	SHUTTLE RACE BASE	
14-2-1-2	S02429101	1	カマイトアンナイ	SHUTTLE RACE THREAD GUIDE	
14-2-1-3	062660412	2	ナベコ318-40X4	SCREW, PAN SM3.18-40X4	
14-2-1-4	152683101	2	オオカマトリツケツメ	S-RACE BASE SETTING CLAW	
14-2-1-5	152684101	2	オオカマトリツケバネ	SPRING, COMPRESSION	
14-2-1-6	402887001	2	ザカネ3.2	WASHER, 3.2	
14-2-1-7	062660712	2	ナベコ318-40X7	SCREW, PAN SM3.18-40X7	
14-2-1-8	S09043000	2	フェルト	FELT	
14-2-1-9	S59886001	2	フェルト	FELT, L=360	

E. 下軸関係 / Lower shaft mechanism

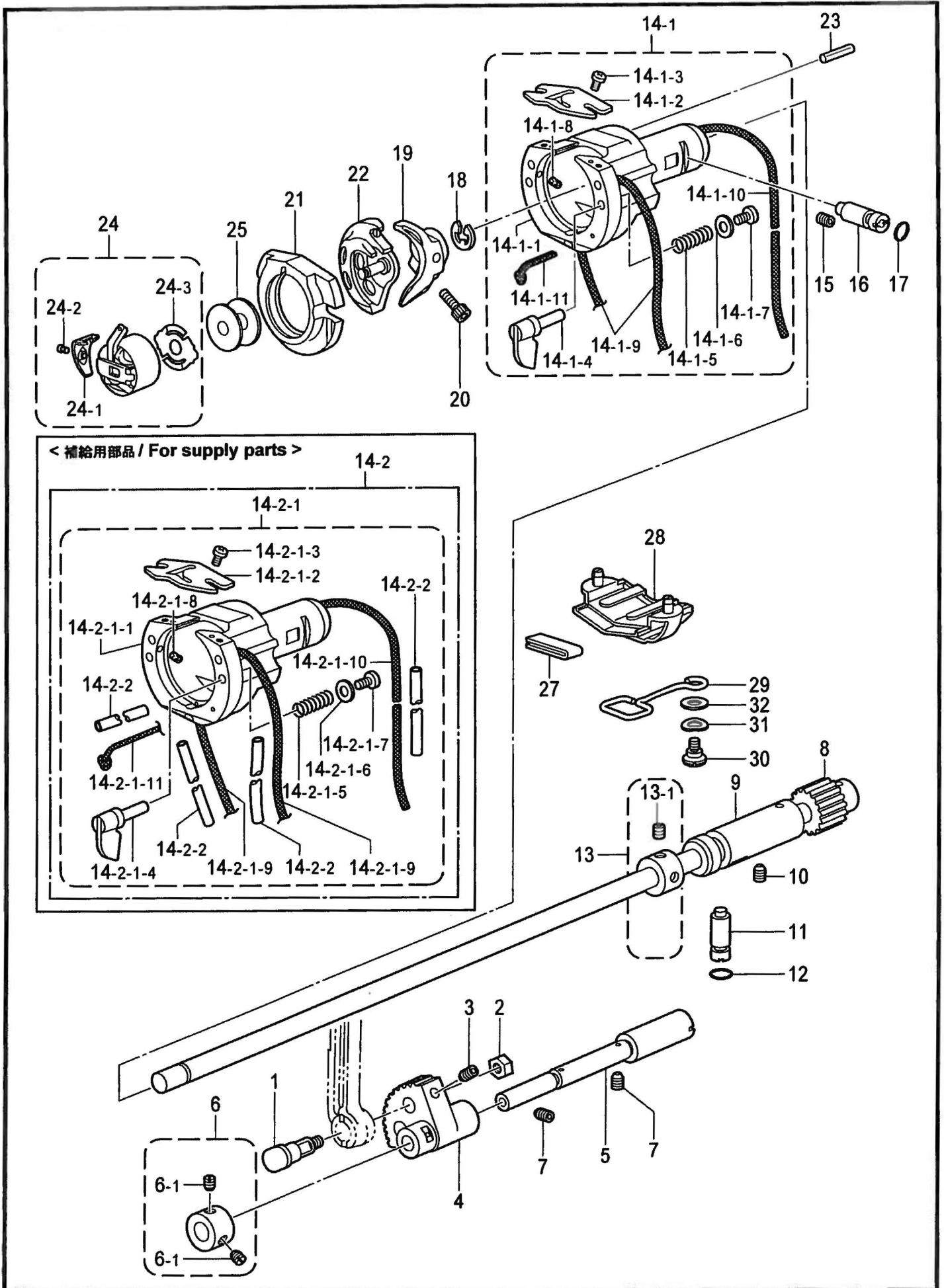

KE-434C/435C-305

E . 下軸関係 / Lower shaft mechanism

REF.NO	CODE	Q'TY	品名	NAME OF PARTS	RM
14-2-1-10	S57965000	1	クミヒモ3X3	WICK, 3X3 L=515	
14-2-1-11	S59886001	1	フェルト	FELT, L=360	
14-2-2	S50529000	4	ビニルチューブ	OIL TUBE, L=320	

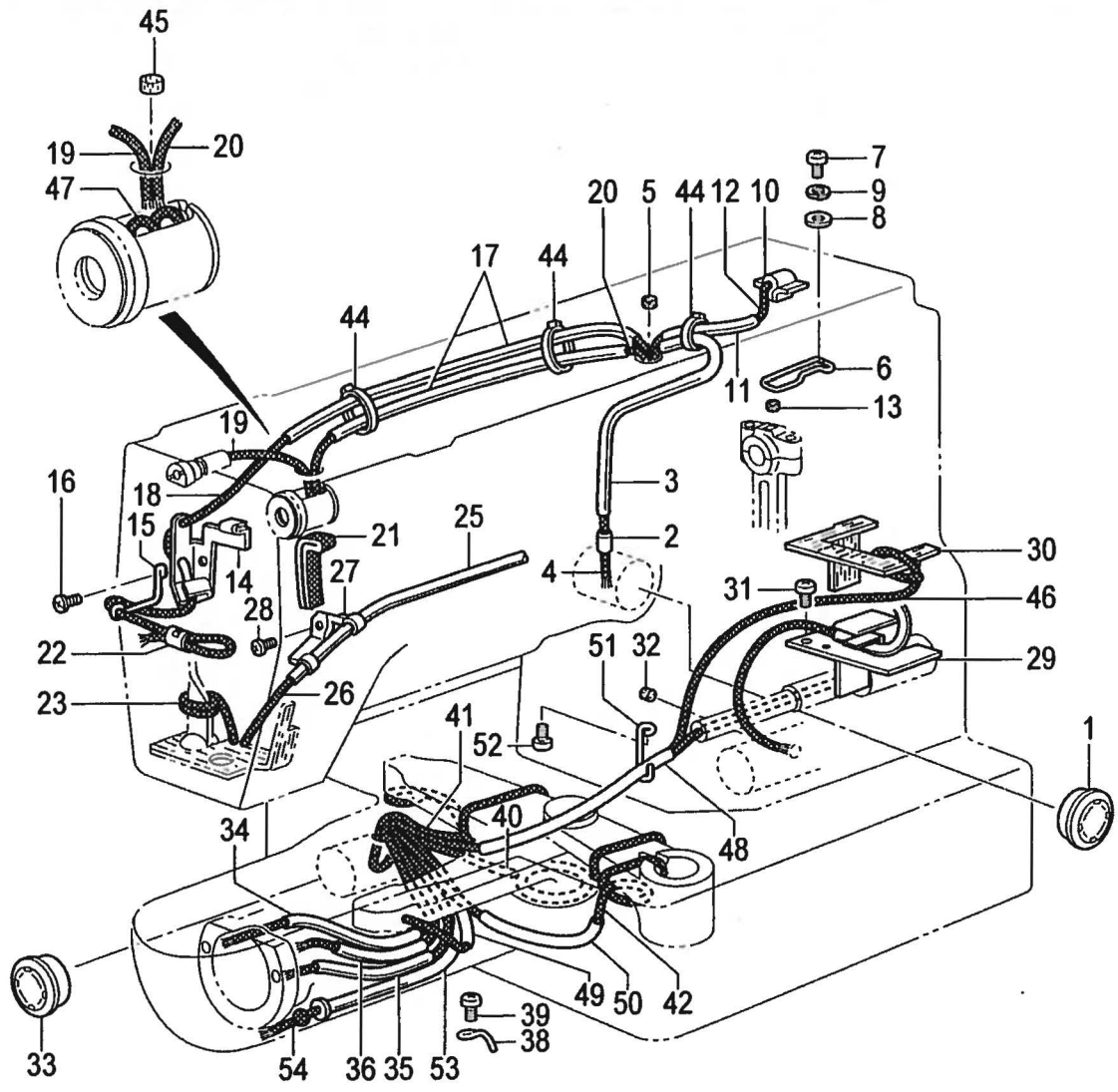

< KE-434C用 / For KE-434C >

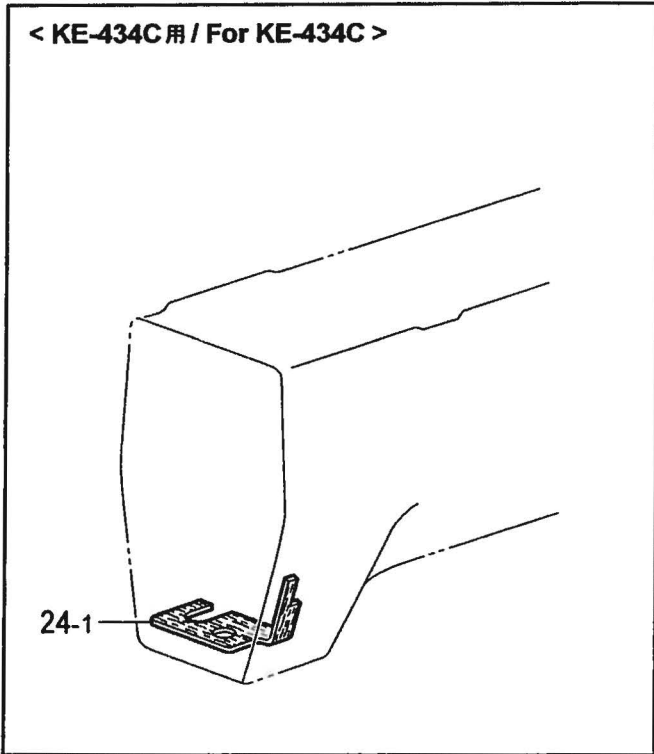

< KE-435C用 / For KE-435C >

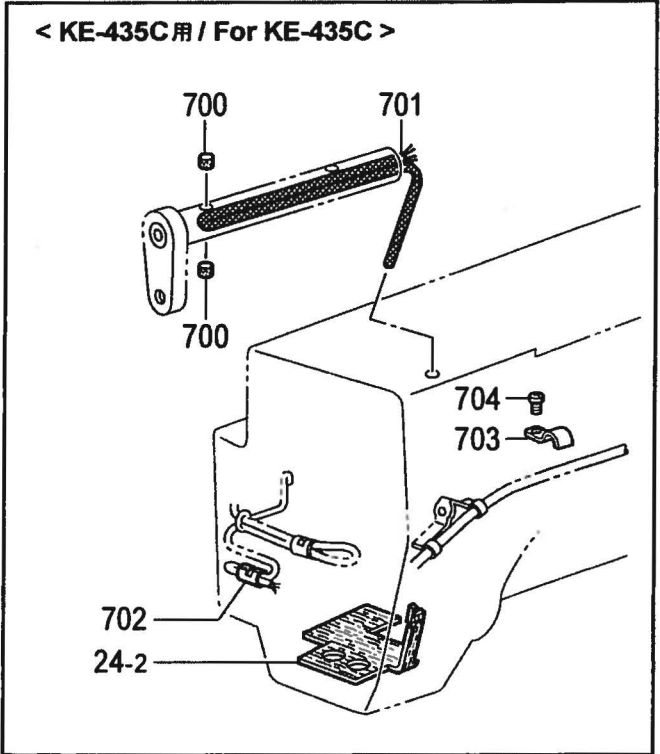

F. 給油潤滑関係 / Lubrication

REF.NO	CODE	Q'TY	ヒンメイ	NAME OF PARTS	RM
1	S49992000	1	オイルホツトマド	OIL GAUGE WINDOW	
2	S07333001	1	オイルクチパイプS	PIPE, S	
3	S07456000	1	ビニールチューブ	OIL TUBE, L=160	
4	148738000	1	クミヒモ	WICK, L=335	
5	107149001	1	フェルト	FELT	
6	S37983001	1	ウワジクキユウササエ	WICK SUPPORT	
7	062680612	1	ナヘコ4.37-40X6	SCREW, PAN SM4.37-40X6	
8	025680232	1	ヒラサカネチユウ4.37	WASHER, PLAIN M 4.37	
9	028680242	1	ハネサカネ2-4.37	WASHER, SPRING 2-4.37	
10	S10478000	1	ロツトキユウフェルト	FELT	
11	S34986000	1	ビニールチューブ	OIL TUBE, L=135	
12	S49982000	1	クミヒモ4X4	WICK, 4X4 L=400	
13	107149001	2	フェルト	FELT	
14	S49959001	1	テンヒンキユウササエ	WICK SUPPORT	
15	S10162201	1	ハリホウヒモササエ	WICK SUPPORT	
16	060670512	1	バインド357-40X5	SCREW, BIND SM3.57-40X5	
17	S49620000	2	ビニールチューブ	OIL TUBE, L=340	
18	S49957000	1	クミヒモ4X4	WICK, 4X4 L=700	
19	S49622000	1	クミヒモ4X4	WICK, 4X4 L=130	
20	S49983000	1	クミヒモ4X4	WICK, 4X4 L=800	
21	S49984000	1	ヒラクミヒモ	FLAT WICK, L=200	
22	104567101	1	クミヒモササエ	WICK SUPPORT	
23	159565000	1	クミヒモ2.5X150	WICK, L=150	
25	S37986000	1	ビニールチューブ	OIL TUBE, L=440	
26	S18093100	1	クミヒモ4X4	WICK, 4X4 L=1100	
27	145547001	1	チューブホルダ	TUBE HOLDER	
28	062670512	1	ナヘコ357-40X5	SCREW, PAN SM3.57-40X5	
29	S37987001	1	シタジクキユウササエ	LOWER SHAFT WICK SUPPORT	
30	S37988000	1	シタジクキユウフェルト	LOWER SHAFT WICK FELT	
31	062680612	1	ナヘコ4.37-40X6	SCREW, PAN SM4.37-40X6	
32	S09043000	1	フェルト	FELT	
33	152948001	1	オイルホツトマド	OIL GAUGE WINDOW	
34	S49623000	1	ビニールチューブ	OIL TUBE, L=280	
35	S49624000	1	ビニールチューブ	OIL TUBE, L=260	
36	S49625000	1	ビニールチューブ	OIL TUBE, L=160	
38	152969001	2	コードササエカネ	CORD HOLDER	
39	062670512	2	ナヘコ357-40X5	SCREW, PAN SM3.57-40X5	
40	148738000	1	クミヒモ	WICK, L=335	
41	148738000	1	クミヒモ	WICK, L=335	
42	152956001	1	クミヒモ4X4	WICK, 4X4 L=500	
44	228475000	3	ケツソクバンド1.9X80	TYING BAND 1.9X80	
45	153924001	1	フェルト	FELT	
46	S49957000	1	クミヒモ4X4	WICK, 4X4 L=700	
47	S49958000	1	クミヒモ4X4	WICK, 4X4 L=70	
48	S49985000	1	ビニールチューブ	OIL TUBE, L=170	
49	S49986000	1	ビニールチューブ	OIL TUBE, L=110	
50	S49987000	1	ビニールチューブ	OIL TUBE, L=150	
51	S49995001	1	コードササエカネ	CORD SUPPORT	
52	062670512	1	ナヘコ357-40X5	SCREW, PAN SM3.57-40X5	
53	S49618000	1	ビニールチューブ	OIL TUBE, L=210	
54	S55659000	1	クミヒモ	WICK, L=300	
			<KE-434C用>	<For KE-434C>	
24-1	S37985000	1	スイアケフェルト	FELT	
			<KE-435C用>	<For KE-435C>	
24-2	S42827200	1	スイアケフェルト	FELT	
700	S09043000	2	フェルト	FELT	
701	108802001	1	クミヒモ4X4	WICK, 4X4 L=250	
702	104567101	1	クミヒモササエ	WICK SUPPORT	
703	140647101	1	コードオサエ	CORD HOLDER	
704	062670612	1	ナヘコ357-40X6	SCREW, PAN SM3.57-40X6	

KE-434C/435C-350

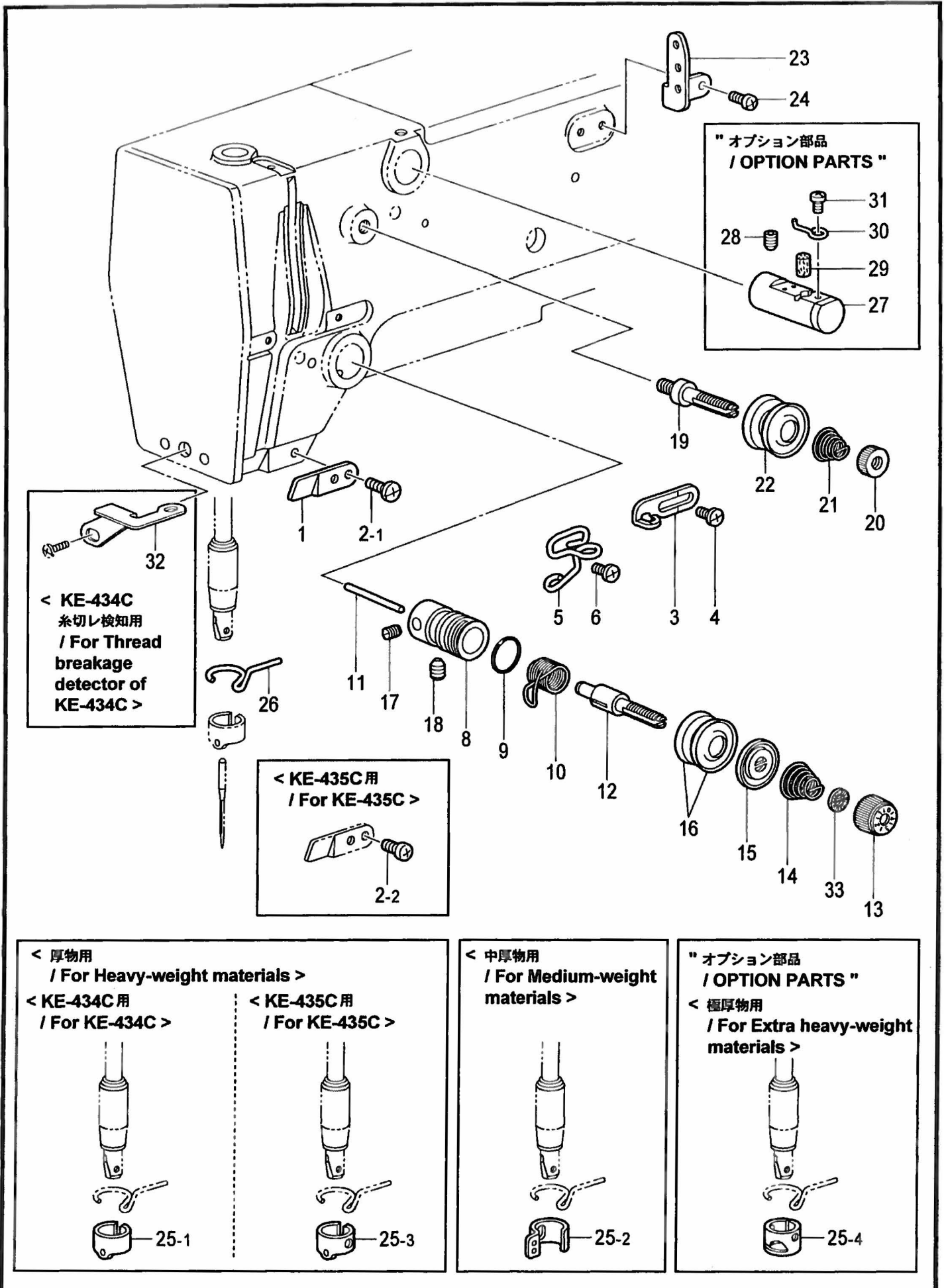

G . 糸通シ関係 / Threading mechanism

REF.NO	CODE	Q'TY	ヒンメイ	NAME OF PARTS	RM
1	S53097001	1	ア-ムトミチ <KE-434C用>	ARM THREAD GUIDE <For KE-434C>	
2-1	060670612	1	ハ-イント357-40X6 <KE-435C用>	SCREW, BIND SM3.57-40X6 <For KE-435C>	
2-2	062710612	1	ナ-コ476-32X6	SCREW, PAN SM4.76-32X6	
3	S49627001	1	ア-ムトカケ	ARM THREAD GUIDE	
4	060670612	1	ハ-イント357-40X6	SCREW, BIND SM3.57-40X6	
5	S51859101	1	ア-ムトアンナイ	ARM THREAD GUIDE	
6	060670612	1	ハ-イント357-40X6	SCREW, BIND SM3.57-40X6	
8	152872001	1	トチヨウシダイ	TENSION BRACKET	
9	114294001	1	リング	O-RING	
10	*	1	トトリハネ	THREAD TAKE-UP SPRING	
11	150551000	1	<KE-434C用> トチユルピン	<For KE-434C> TENSION RELEASE PIN	
11	S12699000	1	<KE-435C用> トチユルピン	<For KE-435C> TENSION RELEASE PIN	
12	116922001	1	トチヨウシホウ	TENSION STUD	
13	S31032001	1	トチヨウシナツ	TENSION NUT	
14	*	1	トチヨウシハネ	TENSION SPRING	
15	159805001	1	トチヨウシサラオサエ	TENSION DISC PRESSER	
16	145446001	2	トチヨウシサラ	TENSION DISC	
17	100402004	1	トメネジ3.57	SET SCREW, SM3.57	
18	S10469001	1	アナトメネジ5.95	SET SCREW, SOCKET SM5.95	
19	115186001	1	シュイトチヨウシホウ	MAIN TENSION STUD	
20	100136001	1	トチヨウシナツ	TENSION NUT	
21	115188001	1	シュイトチヨウシハネ	TENSION SPRING	
22	145446001	2	トチヨウシサラ	TENSION DISC	
23	152889001	1	ミツメトカケ	THREAD RETAINER	
24	062670612	2	ナ-コ357-40X6	SCREW, PAN SM3.57-40X6	
25-1	152890001	1	[厚物用] <KE-434C用> ハリホウイトアンナイA	[For Heavy-weight materials] <For KE-434C> NEEDLE BAR THREAD GUIDE, A	
25-3	S02438001	1	<KE-435C用> ハリホウイトアンナイA	<For KE-435C> N-BAR THREAD GUIDE, A	
25-2	S41222101	1	[中厚物用] ハリホウイトアンナイB	[For Medium-weight materials] NEEDLE BAR THREAD GUIDE, B	
26	152891101	1	ハリホウメタルDトアンナイ	N-BAR BUSH THREAD GUIDE, D	
33	S12441001	1	チヨウシハネウエサガネ	WASHER	
25-4	S02439001	1	" オプション部品 " [極厚物用] ハリホウイトアンナイB	" OPTION PARTS " [For Extra heavy-weight materials] N-BAR THREAD GUIDE, B	
27	152881001	1	エキレイタイクミ	NEEDLE COOLER ASSY	
28	014760632	1	アナクホミ595-28X6	SET SCREW, SOCKET SM5.95-28X6	
29	152883000	1	フェルト8X15.5	FELT, 8X15.5	
30	152884001	1	エキレイトカケ	NEEDLE COOLER THREAD GUIDE	
31	062670412	1	ナ-コ357-40X4	SCREW, PAN SM3.57-40X4	
32	S45083001	1	<KE-434C系切れ検知用> メンタイトアンナイ	<For Thread breakage detector of KE-434C> FACE PLATE THREAD GUIDE	

H. 糸巻関係 / Bobbin winder mechanism

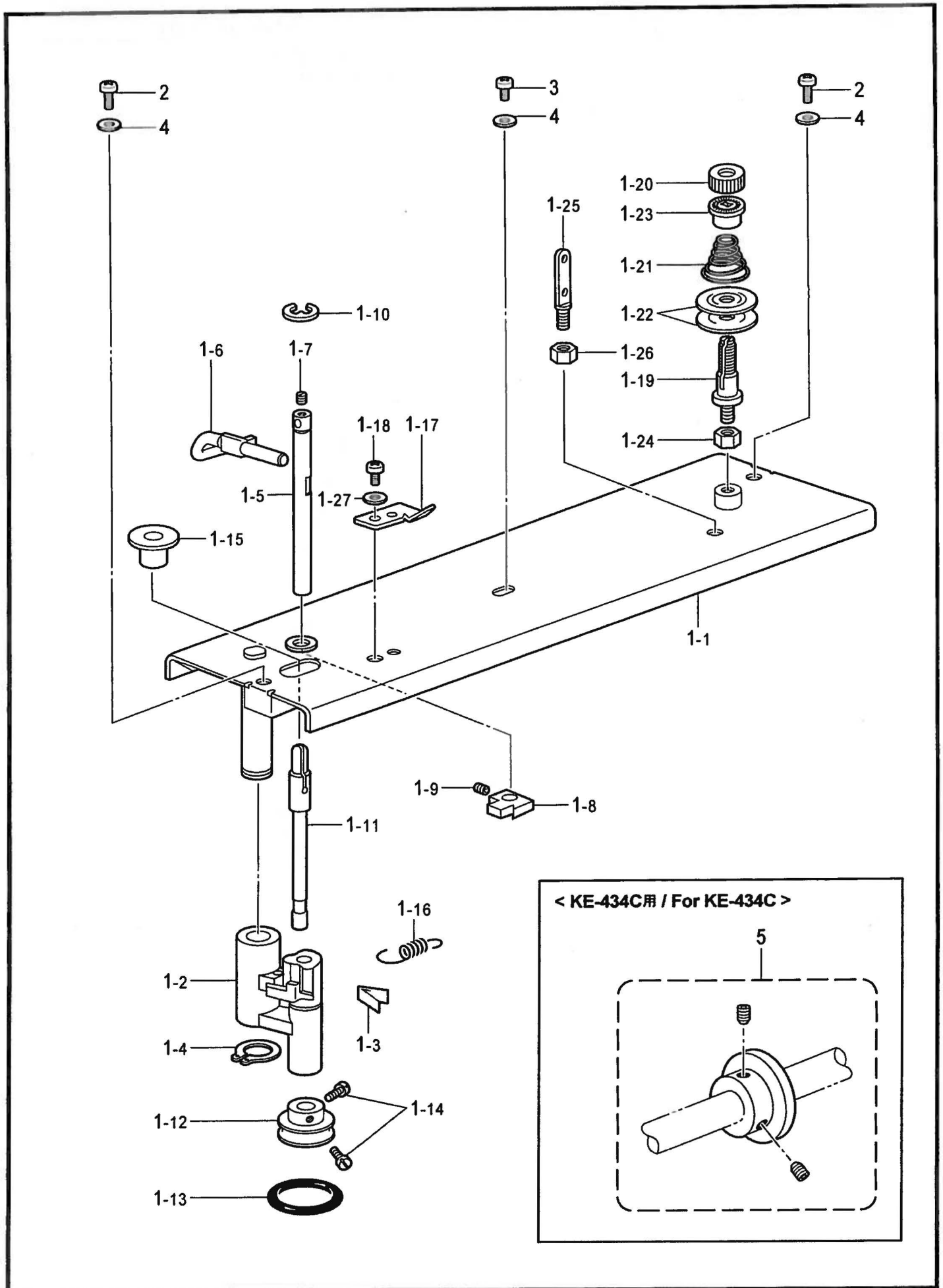

KE-434C/435C-402

H . 糸巻関係 / Bobbin winder mechanism

REF.NO	CODE	Q'TY	ヒンメイ	NAME OF PARTS	RM
1-1	S37991109	1	ウワフタ	TOP COVER	
1-2	S37992100	1	イトマキウデ	BOBBIN WINDER ARM	
1-3	S37993000	1	イタハネ	PLATE SPRING	
1-4	048100142	1	トメワシクヨウC10	RETAINING RING, EXTERNAL C10	
1-5	S37994001	1	イトマキツメジク	BOBBIN WINDER CLAW STUD	
1-6	S37995101	1	ホビンオサエ	BOBBIN PRESSER	
1-7	100402004	1	トメネジ3.57	SET SCREW, SM3.57	
1-8	S37996001	1	イトマキツメ	BOBBIN WINDER CLAW	
1-9	014680622	1	アタメネジ4.37クホミ	SET SCREW, SOCKET (CP) SM4.37	
1-10	048050342	1	トメワE5	RETAINING RING, E5	
1-11	S37997001	1	イトマキジク	BOBBIN WINDER SHAFT	
1-12	154528001	1	イトマキクルマ	BOBBIN WINDER WHEEL	
1-13	120448001	1	ゴムワ	RUBBER BAND	
1-14	120990001	2	アタマツキトメネジ4.37	SET SCREW, (CP) SM4.37-40X8	
1-15	S10174000	1	ホコリヨケイタ	DUST GUARD PLATE	
1-16	S37998001	1	イトマキウデハネ	SPRING	
1-17	157968001	1	メス	KNIFE	
1-18	062680512	1	ナヘコ437-40X5	SCREW, PAN SM4.37-40X5	
1-19	159574101	1	イトチヨウシホウ	TENSION STUD	
1-20	100136001	1	イトチヨウシナツト	TENSION NUT	
1-21	144110001	1	シタルハイトチヨウシハネ	TENSION ADJUSTING SPRING	
1-22	145446001	2	イトチヨウシサラ	TENSION DISC	
1-23	144105000	1	チヨウシハネウエサガネ	TENSION SPRING FLANGE WASHER	
1-24	021680202	1	ナツト2シユ4.37	NUT, 2 SM4.37	
1-25	141590001	1	イトオシホウ	THREADING BAR, U	
1-26	100022004	2	ナツト5.95	NUT, SM5.95	
1-27	025680232	1	ヒラザガネチユウ4.37	WASHER, PLAIN M 4.37	
2	062681212	2	ナヘコ437-40X12	SCREW, PAN SM4.37-40X12	
3	062680612	1	ナヘコ4.37-40X6	SCREW, PAN SM4.37-40X6	
4	025680232	3	ヒラザガネチユウ4.37	WASHER, PLAIN M 4.37	
5	S47335101	1	<KE-434C用> イトマキプーリクミ	<For KE-434C> BOBBIN WINDER PULLEY ASSY	

J. 糸切り関係 / Thread trimmer mechanism

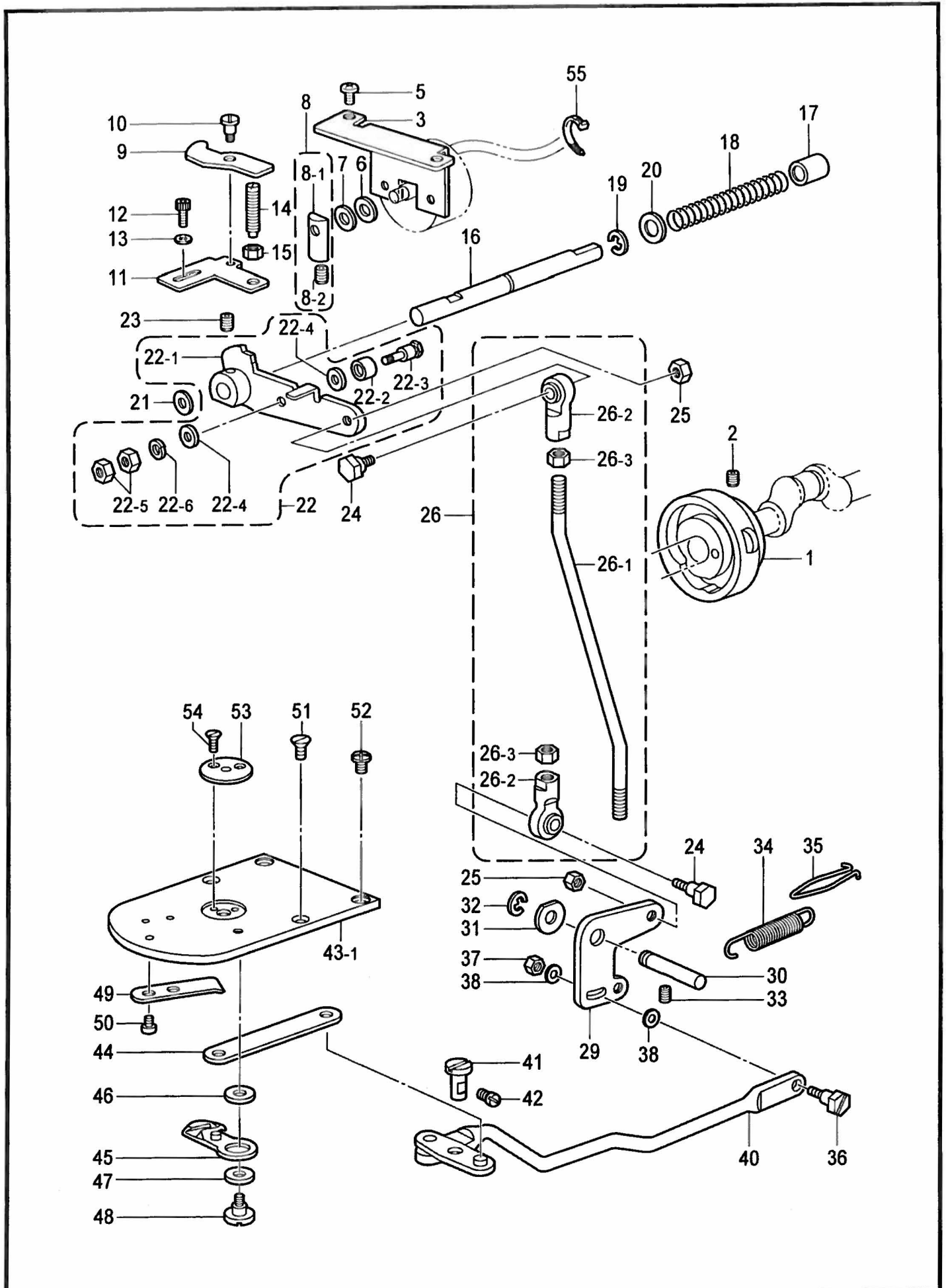

J. 糸切り関係 / Thread trimmer mechanism

REF.NO	CODE	Q'TY	ヒンメイ	NAME OF PARTS	RM
1	S49629201	1	イトキリカム	THREAD TRIMMER CAM	
2	014770632	2	アナクホミ635-40X6	SET SCREW, SOCKET SM6.35-40X6	
3	S38002201	1	ソレノイドトリツケイタ	SOLENOID SETTING PLATE	
5	060681212	2	バインド437-40X12	SCREW, BIND SM4.37-40X12	
6	154599000	1	ソレノイドクッション	SOLENOID CUSHION	
7	S02652001	1	サガネ	WASHER	
8	S23836001	1	ソレノイドレバークミ	SOLENOID LEVER ASSY	
8-1	S02654001	1	ソレノイドレバ	SOLENOID LEVER	
8-2	014680632	1	アナクホミ437-40X6	SET SCREW, SOCKET (CP) SM4.37	
9	S38003101	1	クトウレバ-オシレバ	DRIVING LEVER PUSH LEVER	
10	S49645001	1	ダンネジ4.76	SHOULDER SCREW, SM4.76	
11	S38004002	1	クトウレバ-ストツハ <記号2>	DRIVING LEVER STOPPER <Mraked in 2>	
11	S38004003	1	クトウレバ-ストツハ <記号3>	DRIVING LEVER STOPPER <Mraked in 3>	
11	S38004004	1	クトウレバ-ストツハ <記号4>	DRIVING LEVER STOPPER <Mraked in 4>	
12	S59893001	2	アナホルルト437-40X10	BOLT, SOCKET SM4.37-40X10	
13	148847001	2	サガネ	WASHER, PLAIN 4.76	
14	159905001	1	トメヌイチヨウセツネジ	ADJUSTING SCREW	
15	105812003	1	ナツト7.94	NUT, SM7.94	
16	S49644001	1	クトウレバ-アンナインク	DRIVING LEVER GUIDE SHAFT	
17	231071001	1	メタル8X15	BUSH, 8X15	
18	S32235001	1	ヌノオサエバネ	SPRING, COMPRESSION	
19	048070342	1	トメワE7	RETAINING RING, E7	
20	153596001	1	サガネ	WASHER	
21	154596000	1	イトキリカムレバ-クッション	CUSHION	
22	S49646101	1	イトキリクトウレバークミ	THREAD DRIVING LEVER ASSY	
22-1	S59874001	1	イトキリクトウレバ	THREAD DRIVING LEVER	
22-2	S59872001	1	イトキリコロ	THREAD TRIMMER ROLLER	
22-3	S59871001	1	ダンネジ4.37	SHOULDER SCREW, SM4.37	
22-4	S59873001	2	サガネ	WASHER, PLAIN	
22-5	SA0049001	2	ナツト4.37	NUT, SM4.37	
22-6	028680242	1	バネサガネ2-4.37	WASHER, SPRING 2-4.37	
23	014770632	1	アナクホミ635-40X6	SET SCREW, SOCKET SM6.35-40X6	
24	S02354001	2	タマツキテダンネジB	SHOULDER SCREW, B	
25	100022005	2	ナツト5.95	NUT, SM5.95	
26	S49648001	1	イトキリロツトクミ	THREAD TRIMMER ROD ASSY	
26-1	S49649001	1	イトキリロツト	THREAD TRIMMER ROD	
26-2	141492001	2	タマツキテクミ	JOINT ASSY	
26-3	100022005	2	ナツト5.95	NUT, SM5.95	
29	S49650001	1	イトキリレバ	THREAD TRIMMER LEVER	
30	S10195101	1	イトキリレバ-ジク	THREAD TRIMMER LEVER SHAFT	
31	110367001	1	サガネ	WASHER, PLAIN SPECIAL 8	
32	048060342	1	トメワE6	RETAINING RING, E6	
33	014760632	1	アナクホミ595-28X6	SET SCREW, SOCKET SM5.95-28X6	
34	S38011001	1	イトキリモトシバネ	SPRING, EXTENSION	
35	S49651001	1	バネカケ	SPRING HOOK	
36	110233001	1	ダンネジ4.76	SHOULDER SCREW, SM4.76	
37	110161004	1	ナツト4.76	NUT, SM4.76	
38	S49994001	2	サガネ4.76	WASHER, PLAIN 4.76	
40	S38012001	1	レンカンレバークミ	CONNECTING ROD LEVER ASSY	
41	S10202201	1	レンカンレバ-ジク	LEVER SHAFT	
42	121007001	1	アタマツキトメネジ4.37	SET SCREW, SM4.37	
43	S38015001	1	ハリイタ	NEEDLE PLATE	
44	S38016001	1	イトキリレンカン	THREAD CONNECTING ROD	
45	S49988001	1	イトウハNクミ	MOVABLE KNIFE ASSY, N	
46	S10208001	1	イトウハカンザ <t=0.4>	MOVABLE KNIFE SPACER <t=0.4>	
46	S10208002	1	イトウハカンザ <t=0.5>	MOVABLE KNIFE SPACER <t=0.5>	
46	S10208003	1	イトウハカンザ <t=0.6>	MOVABLE KNIFE SPACER <t=0.6>	
47	S00705001	1	イトウハカラー	MOVABLE KNIFE COLLAR	
48	S10209101	1	シメネジ4.37	SCREW, SM4.37	
49	S10210201	1	コテイハ	FIXED KNIFE	

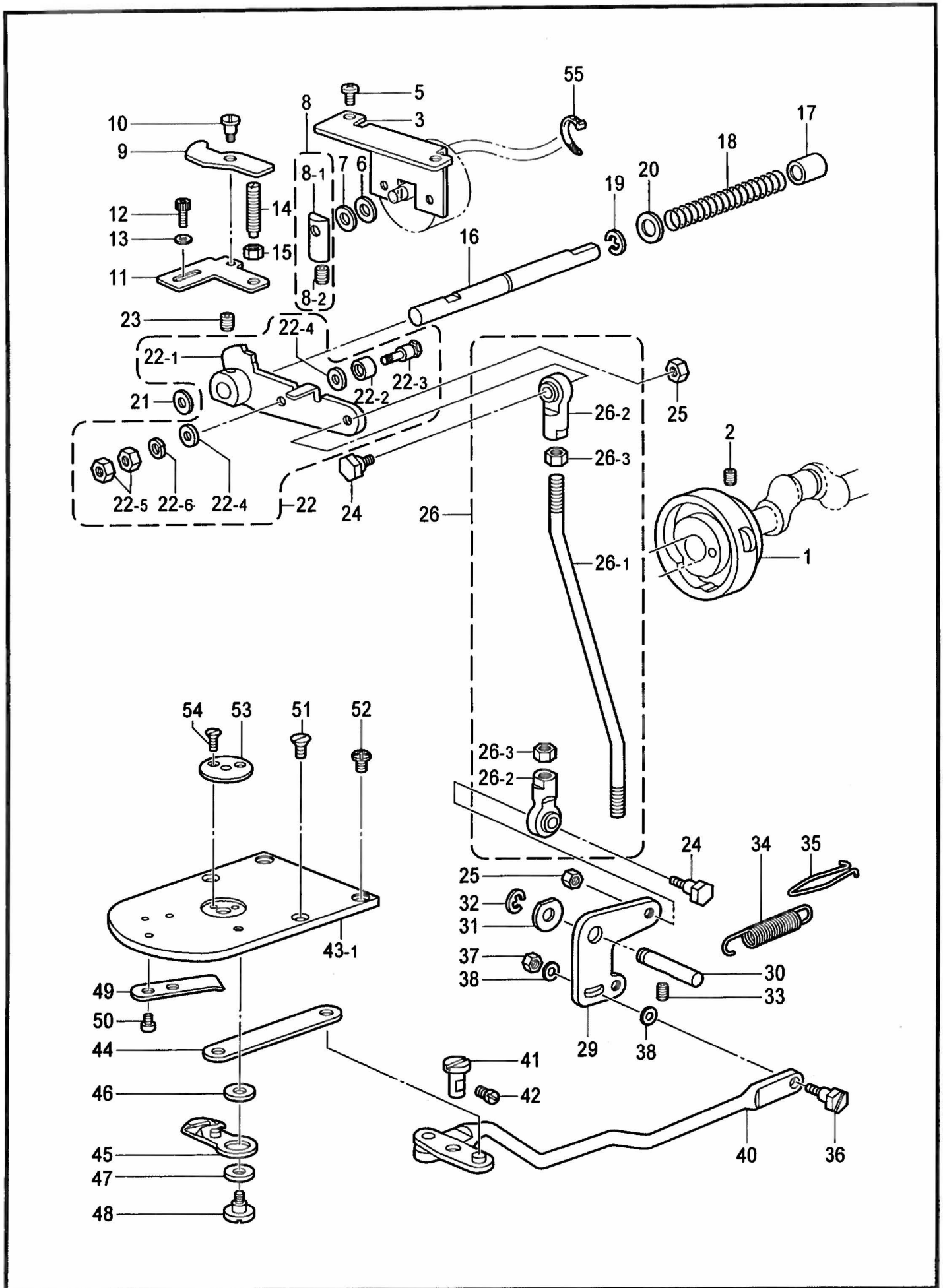

J. 糸切り関係 / Thread trimmer mechanism

REF.NO	CODE	Q'TY	品名	NAME OF PARTS	RM
50	111140002	2	シメネジ2.38	SCREW, SM2.38	
51	100032004	2	サラネジ4.37	SCREW, FLAT SM4.37-40X8	
52	S11244001	2	シメネジ4.37	SCREW, SM4.37	
53	*	1	ハリアナイタ	NEEDLE HOLE PLATE	
54	100360003	2	サラネジ2.38	SCREW, FLAT SM2.38	
55	228475000	1	ケツソクバンド1.9X80	TYING BAND 1.9X80	

< 電磁式用 / For Solenoid type >

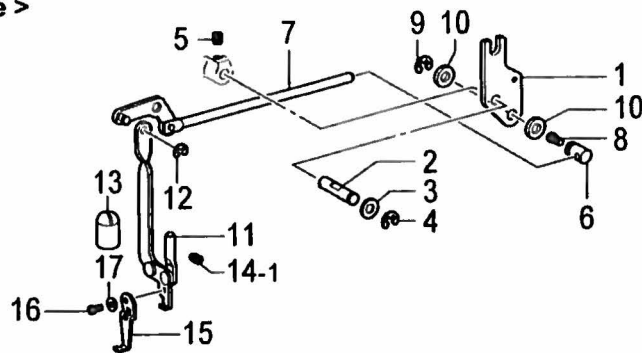

< エアー式用、反転用 / For Pneumatic type & Inner clamping device >

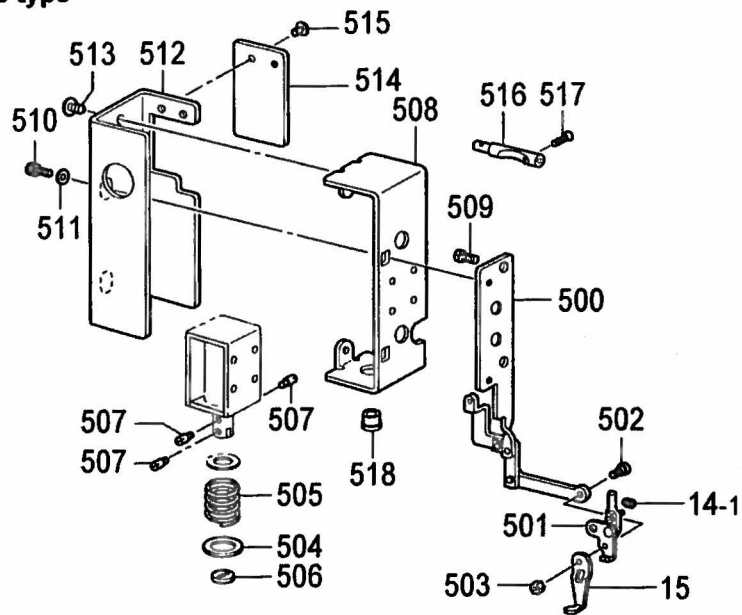

< KE-435C用 / For KE-435C >

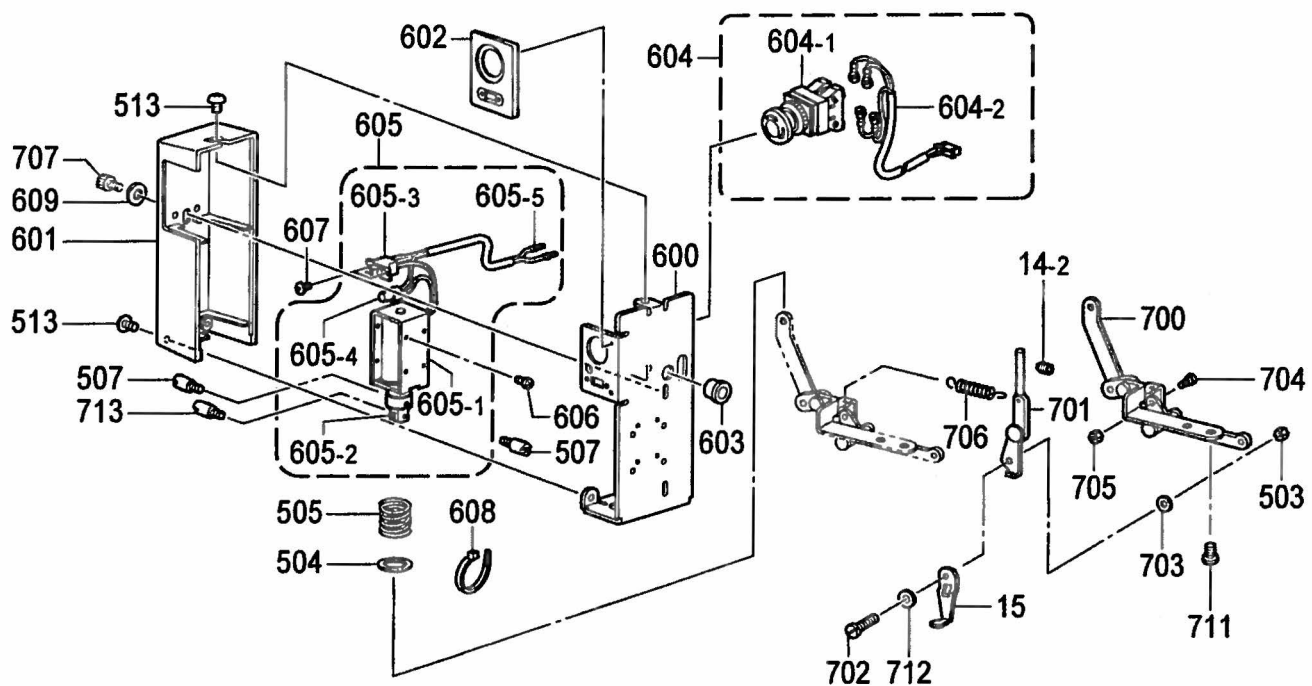

K . 糸払イ関係 / Thread wiper mechanism

REF.NO	CODE	Q'TY	ヒンメイ	NAME OF PARTS	RM
			<電磁式用>	<For Solenoid type>	
1	S49652101	1	ワイパー駆動レバー	THREAD WIPER DRIVING LEVER	
2	152822101	1	ワイパーシャフト	THREAD WIPER SHAFT	
3	025770232	1	ヒラサガネチユウ6.35	WASHER, PLAIN M 6.35	
4	048040342	1	トメワE4	RETAINING RING, E4	
5	014760632	1	アナクホミ595-28X6	SET SCREW, SOCKET SM5.95-28X6	
6	S38024101	1	ワイパーロッドシャフト	THREAD WIPER ROD SHAFT	
7	S38025101	1	ワイパーロッドアッシー	THREAD WIPER ROD ASSY	
8	121007001	1	アタマツキトメネジ4.37	SCREW	
9	048060342	1	トメワE6	RETAINING RING, E6	
10	116629001	2	サガネ	WASHER	
11	S41284301	1	ワイパーウデクミ	THREAD WIPER ARM ASSY	
12	048030342	1	トメワE3	RETAINING RING, E3	
13	152827001	1	オイルキリセン	OIL CAP	
14-1	014710532	1	アナクホミ476-32X5	SET SCREW, SOCKET SM4.76-32X5	
15	SA2150001	1	ワイパーA	THREAD WIPER, A	
16	062670412	1	ナベコ357-40X4	SCREW, PAN SM3.57-40X4	
17	141542001	1	サラネジ3.18	SCREW 3.18	
			<エア一式用、反転用>	<For Pneumatic type & Inner clamping device>	
14-1	014710532	1	アナクホミ476-32X5	SET SCREW, SOCKET SM4.76-32X5	
15	156206101	1	ワイパーA	THREAD WIPER, A	
500	S41656001	1	イトハラレンカンクミ	TR-WIPER CONNECTING ROD ASSY	
501	S44600001	1	ワイパーウデクミ	THREAD WIPER ARM ASSY	
502	153112001	1	ダンネジ3.57	SHOULDER SCREW, SM3.57	
503	021670202	1	2シュナツト357-40	NUT, 2 SM3.57-40	
504	S41205001	1	ヒラサガネ	WASHER, PLAIN	
505	S41206001	1	イトハラワイパー	THREAD WIPER SPRING	
506	S41207000	1	スペーサゴム	SPACER RUBBER	
507	S25456001	3	プランジャピン	PLUNGER PIN	
508	S42017109	1	Wソレノイドトリツケイタ	W-SOLENOID SETTING PLATE	
509	062680812	2	ナベコ437-40X8	SCREW, PAN SM4.37-40X8	
510	018400632	2	アナホルルト4X6	BOLT, SOCKET M4X6	
511	100645003	2	サガネ	WASHER	
512	S42018109	1	Wソレノイドカバー	WIPER SOLENOID COVER	
513	008400604	2	トラスコ4X6	SCREW, TRUSS M4X6	
514	S37806109	1	ソレノイドカバー-E7タ	SOLENOID COVER LID, E	
515	008400604	2	トラスコ4X6	SCREW, TRUSS M4X6	
516	S41657001	1	イトユルメロッドDW	TENSION RELEASE ROD, DW	
517	061350616	1	サラコ35X6	SCREW, FLAT M3.5X6	
518	104449001	1	ゴムセン15.5	RUBBER CAP, 15.5	
			<KE-435C用>	<For KE-435C>	
14-2	014760632	1	アナクホミ595-28X6	SET SCREW, SOCKET SM5.95-28X6	
15	156206101	1	ワイパーA	THREAD WIPER, A	
503	021670202	1	2シュナツト357-40	NUT, 2 SM3.57-40	
505	S41206001	1	イトハラワイパー	THREAD WIPER SPRING	
504	S41205001	1	ヒラサガネ	WASHER, PLAIN	
507	S25456001	2	プランジャピン	PLUNGER PIN	
600	S55149100	1	イトハラISOLトリツケイタ	T-WIPER SOLENOID SETTING PLATE	
601	S55150000	1	イトハラISOLカバー	THREAD WIPER SOLENOID COVER	
513	S55151000	3	トラスコ4X6	SCREW, TRUSS M4X6	
602	S55133000	1	イトハラISOLカバー-フタ	SOLENOID COVER LID	
603	S38059000	1	グロメットNG79F	RUBBER CAP, NG79F	
604	S57878001	1	EMロックスイッチクミ	EM-LOCK SWITCH ASSY	
604-1	S52744000	1	スイッチA22E-M-11	SWITCH, A22E-M-11	
604-2	S49466000	1	EMSWハーネス	EM-SWITCH HARNESS	
605	S41202151	1	イトハラISOLソレノイド	THREAD WIPER SOLENOID ASSY	
605-1	S41203051	1	イトハラISOLソレノイド	THREAD WIPER SOLENOID	

KE-434C/435C-405

< 電磁式用 / For Solenoid type >

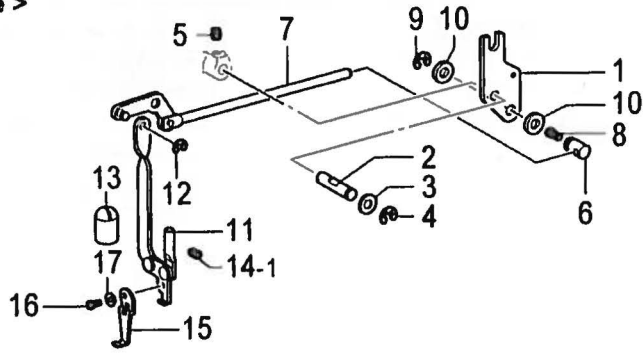

< エアー式用、反転用 / For Pneumatic type & Inner clamping device >

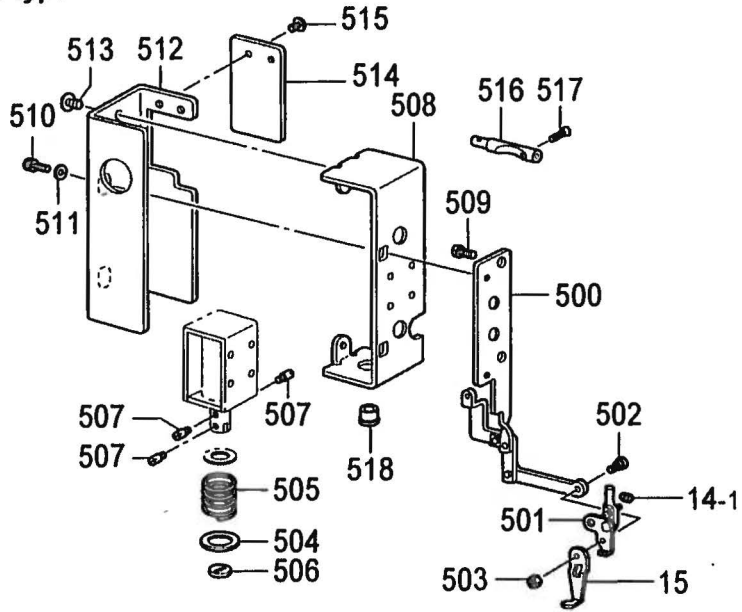

< KE-435C用 / For KE-435C >

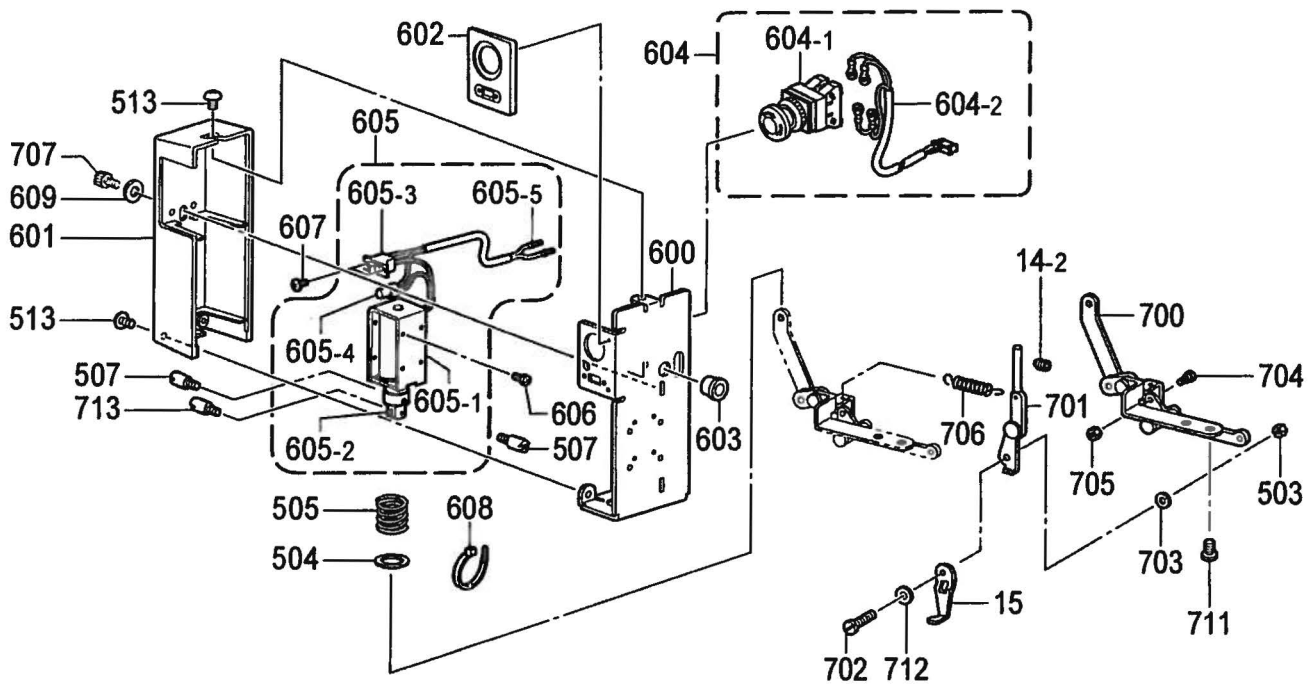

K . 糸払イ関係 / Thread wiper mechanism

REF.NO	CODE	Q'TY	ヒンメイ	NAME OF PARTS	RM
605-2	S41204050	1	プランジヤゴム	PLUNGER RUBBER	
605-3	S02664051	1	イトハライスイッチ	THREAD WIPER SWITCH	
605-4	S02665050	1	ヘイタンセツゾクシ	TERMINAL CONNECTOR	
605-5	143549050	2	ピンターミナルオス	TERMINAL PIN, MALE	
606	062300616	4	ナベコ3X6	SCREW, PAN M3X6	
607	S55184000	2	トラスコ3X6	SCREW, TRUSS M3X6	
608	228475000	2	ケツソクバンド1.9X80	FASTENING BAND, 1.9X80	
609	100645003	2	ザガネ	WASHER	
700	S42859001	1	イトハライレンカンヨコミ	T-WIPER CONNECTING ROD ASSY	
701	S42864101	1	ワイパーウデクミ	WIPER ARM ASSY	
702	S13385001	1	シメネジ3.57X10	SCREW, SM3.57-40X10	
703	S12668001	1	カラー	COLLAR	
704	100659001	1	ダンネジ3.18	SHOULDER SCREW, SM3.18	
705	021660102	1	1シユナツト318-40	NUT, 1 SM3.18-40	
706	159111001	1	Cクラッチアンナイバネ	C CLUTCH GUIDE SPRING	
707	S59893001	2	アナボルト437-40X10	BOLT, SOCKET SM4.37-40X10	
711	S59892001	2	アナボルト437-40X5	BOLT, SOCKET SM4.37-40X5	
712	S21875001	1	ザガネ	WASHER	
713	S25456001	1	プランジヤピン	PLUNGER PIN	

< KE-434C用 / For KE-434C >

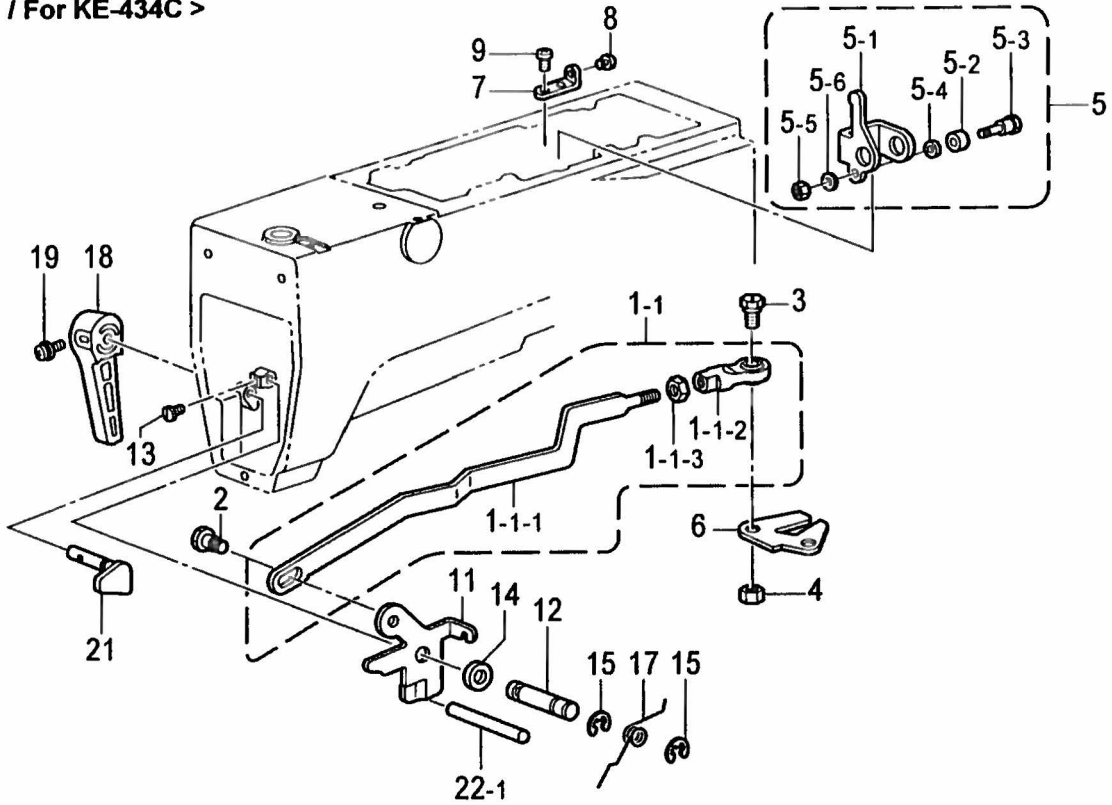

< KE-435C用 / For KE-435C >

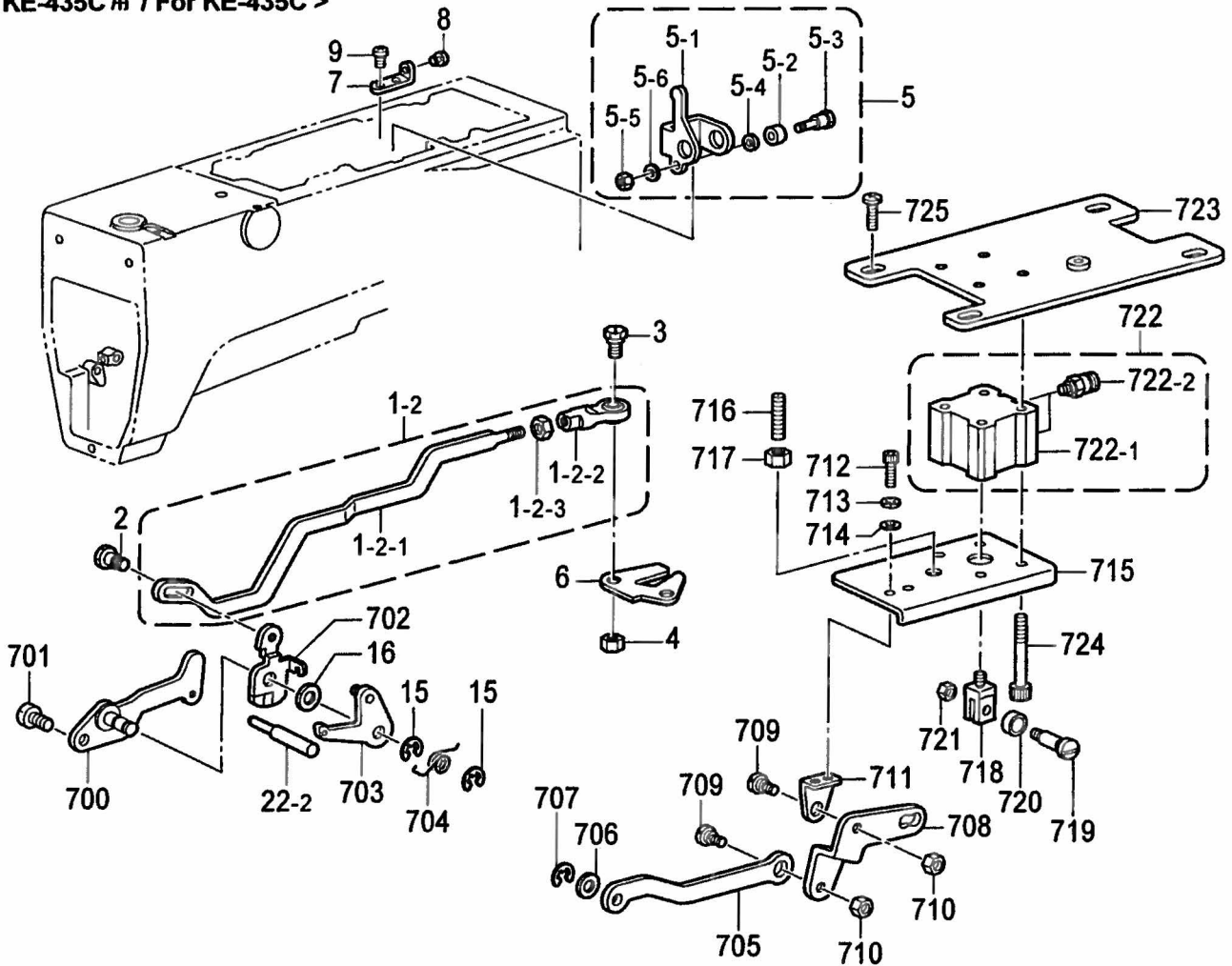

L . 糸締メ関係 / Thread nipper mechanism

REF.NO	CODE	Q'TY	ヒンメイ	NAME OF PARTS	RM
			<KE-434C用>	<For KE-434C>	
1-1	S49665001	1	イトウルメロツト`クミ	TENSION RELEASE ROD ASSY	
1-1-1	S49666001	1	イトウルメロツト`	TENSION RELEASE ROD	
1-1-2	141492001	1	タマツキ`テクミ	JOINT ASSY	
1-1-3	100022005	1	ナツト5.95	NUT, SM5.95	
2	145478101	1	ダンネジ`4.76	SHOULDER SCREW, SOCKET SM4.76	
3	S02354001	1	タマツキ`テダンネジ`B	SHOULDER SCREW, B	
4	100022005	1	ナツト5.95	NUT, SM5.95	
5	S49653001	1	イトウルメクド`ウレバ`クミ	TR-RELEASE DRIVING LEVER ASSY	
5-1	S49654001	1	イトウルメクド`ウレバ`	TENSION RELEASE DRIVING LEVER	
5-2	153597001	1	シタイトサハ`キカラ`	LOWER THREAD RETAINER COLLAR	
5-3	S30033001	1	ダンネジ`3.57	SHOULDER SCREW, SM3.57	
5-4	S49655001	1	カラ`	COLLAR	
5-5	106129002	1	ナツト3.57	NUT, SM3.57	
5-6	028350242	1	ハ`ネサ`ガ`ネ2-3.5	WASHER, SPRING 2-3.5	
6	S49656001	1	イトウルメレバ`U	TENSION RELEASE LEVER, U	
7	S49657001	1	ユルメレバ`U`ストツハ`	RELEASE LEVER U STOPPER	
8	S19748001	1	サド`ウクランククツシヨ`ン	CUSHION	
9	062680812	2	ナベ`コ437-40X8	SCREW, PAN SM4.37-40X8	
11	S38032001	1	イトウルメレバ`	TENSION RELEASE LEVER	
12	S46734001	1	オサエアゲレバ`シク	W-CLAMP LEVER LIFTER SHAFT	
13	S01998001	1	アタマツキトメネジ`3.57	SET SCREW, SM3.57-40X6	
14	S38033001	1	カラ`13	COLLAR, 13	
15	048040342	2	トメワE4	RETAINING RING, E4	
17	SA0703001	1	イトウルメレバ`ハ`ネ	TENSION RELEASE LEVER SPRING	
18	S31006001	1	オサエアゲ`テコ	LIFTING LEVER	
19	S39051001	1	ナベ`サ`クミ35X12	SCREW, PAN (S/P W) M3.5X12	
21	S31952001	1	オサエアゲ`クランク	PRESSER BAR LIFTER CRANK	
22-1	S10239001	1	イトウルメホ`ウ	TENSION RELEASE STUD	
			<KE-435C用>	<For KE-435C>	
1-2	S55108001	1	イトウルメロツト`クミ	TENSION RELEASE ROD ASSY, SF	
1-2-1	S55109001	1	イトウルメロツト`	TENSION RELEASE ROD	
1-2-2	141492001	1	タマツキ`テクミ	JOINT ASSY	
1-2-3	100022005	1	ナツト5.95	NUT, SM5.95	
2	145478101	1	ダンネジ`4.76	SHOULDER SCREW, SOCKET SM4.76	
3	S02354001	1	タマツキ`テダンネジ`B	SHOULDER SCREW, B	
4	100022005	1	ナツト5.95	NUT, SM5.95	
5	S49653001	1	イトウルメクド`ウレバ`クミ	TR-RELEASE DRIVING LEVER ASSY	
5-1	S49654001	1	イトウルメクド`ウレバ`	TENSION RELEASE DRIVING LEVER	
5-2	153597001	1	シタイトサハ`キカラ`	LOWER THREAD RETAINER COLLAR	
5-3	S30033001	1	ダンネジ`3.57	SHOULDER SCREW, SM3.57	
5-4	S49655001	1	カラ`	COLLAR	
5-5	106129002	1	ナツト3.57	NUT, SM3.57	
5-6	028350242	1	ハ`ネサ`ガ`ネ2-3.5	WASHER, SPRING 2-3.5	
6	S49656001	1	イトウルメレバ`U	TENSION RELEASE LEVER, U	
7	S49657001	1	ユルメレバ`U`ストツハ`	RELEASE LEVER U STOPPER	
8	S19748001	1	サド`ウクランククツシヨ`ン	CUSHION	
9	062680812	2	ナベ`コ437-40X8	SCREW, PAN SM4.37-40X8	
15	048040342	2	トメワE4	RETAINING RING, E4	
16	109763002	1	サ`ガ`ネ	WASHER	
22-2	S55199001	1	イトウルメピンL	TENSION RELEASE PIN, L	
700	S42870201	1	イトウルメブ`ラケツト	TENSION RELEASE BRACKET	
701	062771012	1	ナベ`コ635-40X10	SCREW, PAN SM6.35-40X10	
702	S42873101	1	イトウルメレバ`	T-RELEASE LEVER	
703	S42871201	1	オサエアシアゲレバ`クミ	WORK CLAMP LIFTER LEVER ASSY	
704	S10229101	1	オサエレバ`ハ`ネ	SPRING	
705	S43900001	1	カンケツリンクA	STEPPING LINK, A	
706	025750132	1	ヒラサ`ガ`ネシヨウ5.56	WASHER, PLAIN S 5.56	
707	048040342	1	トメワE4	RETAINING RING, E4	

< KE-434C 用 / For KE-434C >

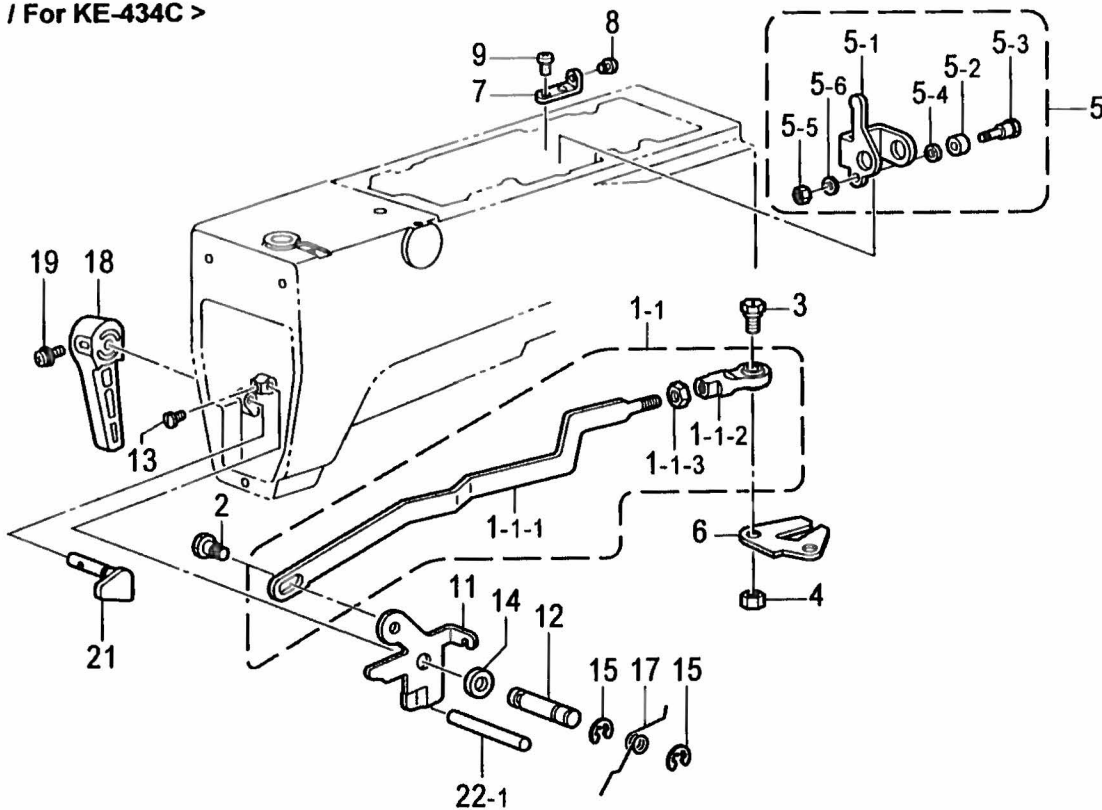

< KE-435C 用 / For KE-435C >

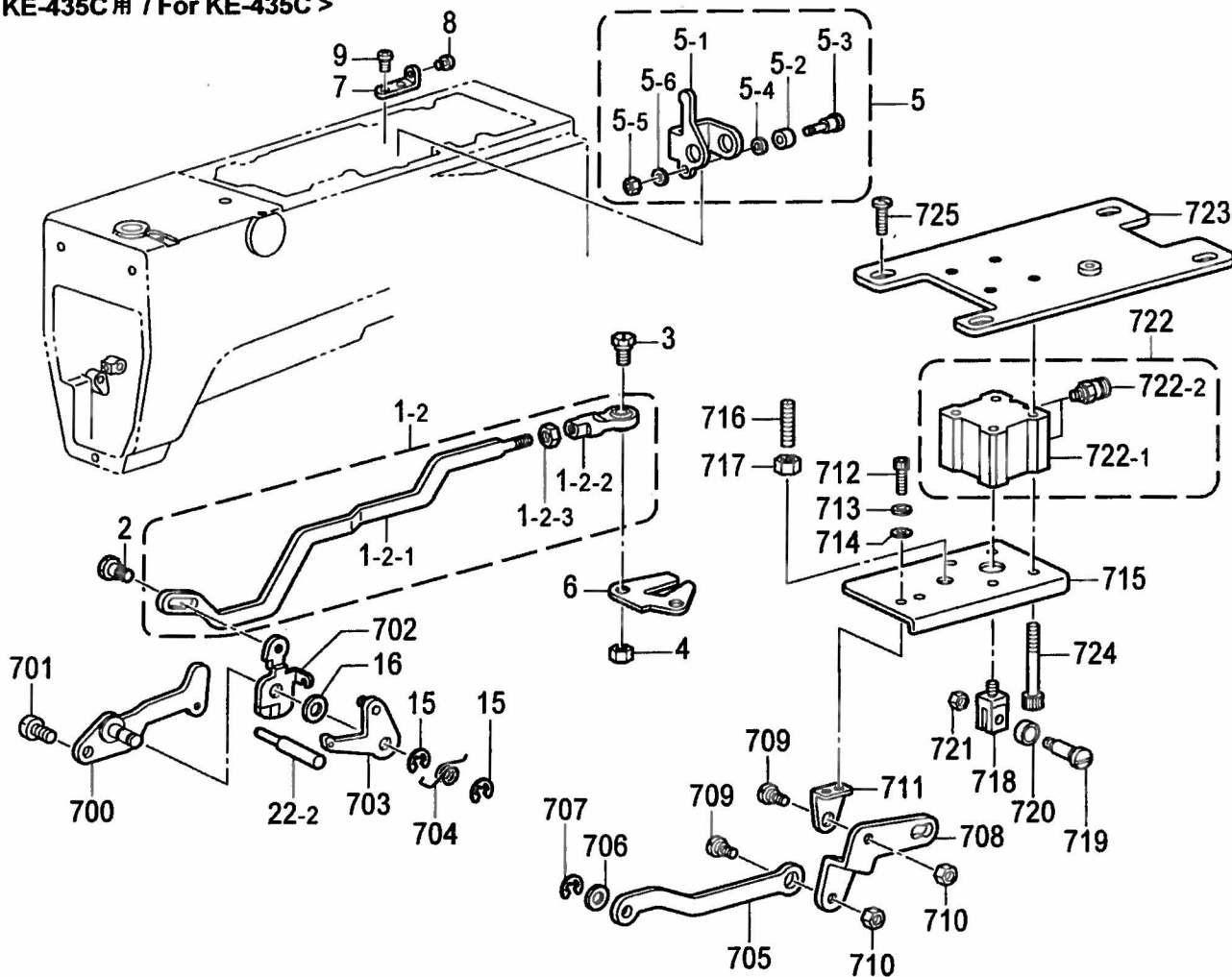

L . 糸締メ関係 / Thread nipper mechanism

REF.NO	CODE	Q'TY	ヒンメイ	NAME OF PARTS	RM
			<KE-435C用>	<For KE-435C>	
708	S43901001	1	カンケツリンクB	STEPPING LINK, B	
709	151907001	2	ダンネジ 5.95	STUD SCREW 5.95	
710	100022005	2	ナツト 5.95	NUT, SM5.95	
711	S43902001	1	カンケツリンクC	STEPPING LINK, C	
712	S59893001	2	アナボルト 437-40X10	BOLT, SOCKET SM4.37-40X10	
713	028680242	2	ハネサガネ 2-4.37	WASHER, SPRING 2-4.37	
714	100645003	2	サガネ	WASHER	
715	S43909001	1	カンケツリンクベース	STEPPING LINK BASE	
716	159905001	1	トメヌイチヨウセツネジ	ADJUSTING SCREW	
717	106147002	1	ナツト 7.94	NUT, SM7.94	
718	S43903001	1	シリンダツギテ	CYLINDER JOINT	
719	148764001	1	ダンネジ 4.76	SHOULDER SCREW, SM4.76	
720	S10123001	1	オサエカムカラー	COLLAR	
721	110161004	2	ナツト 4.76	NUT, SM4.76	
722	S46144100	1	シリンダ 25X15クミ	CYLINDER ASSY, 25X15	
722-1	S46145000	1	シリンダ 25X15	CYLINDER, 25X15	
722-2	S04905000	2	ハーフユニオン	HALF UNION	
723	S43904101	1	エアシリンダトリツケイタ	AIR CYLINDER SETTING PLATE	
724	S24729000	4	CQ2ボルト M5X45	BOLT, CQ2 M5X45	
725	060681212	4	ハインド 437-40X12	SCREW, BIND SM4.37-40X12	

< KE-434C用 / For KE-434C >

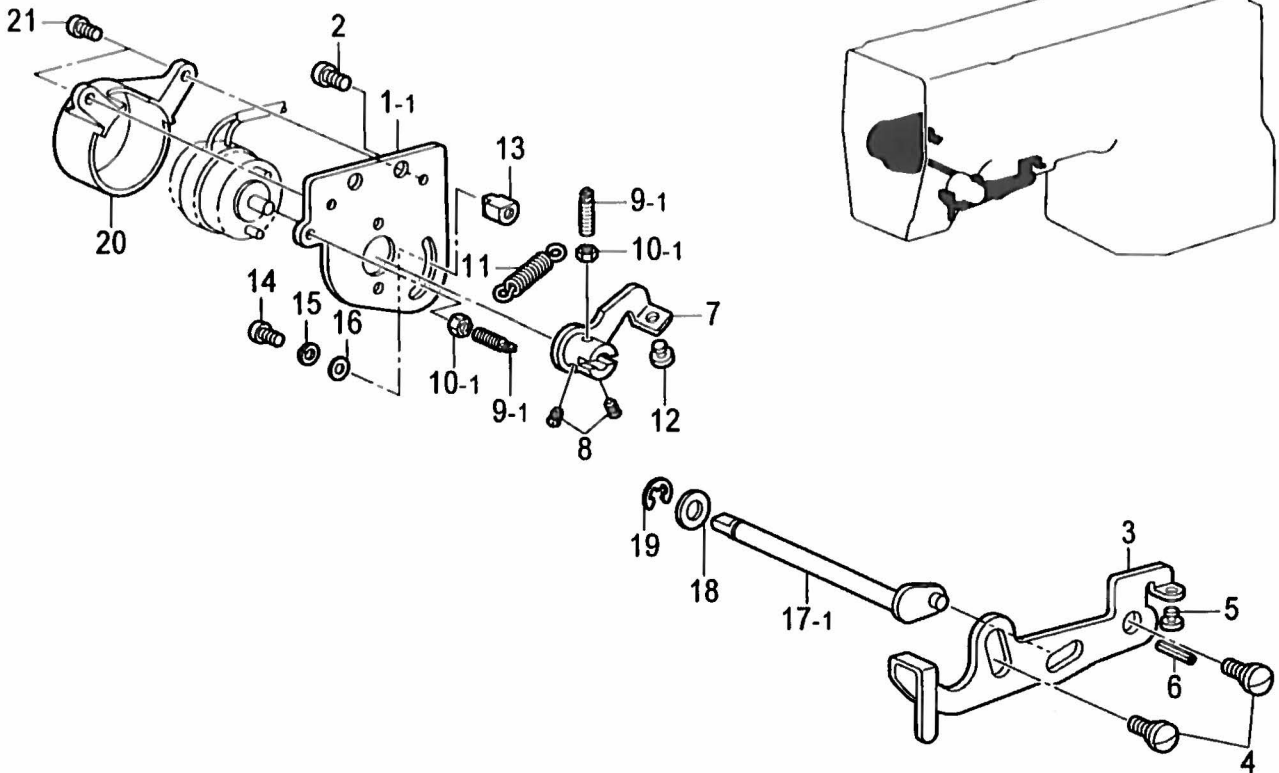

< KE-435C用 / For KE-435C >

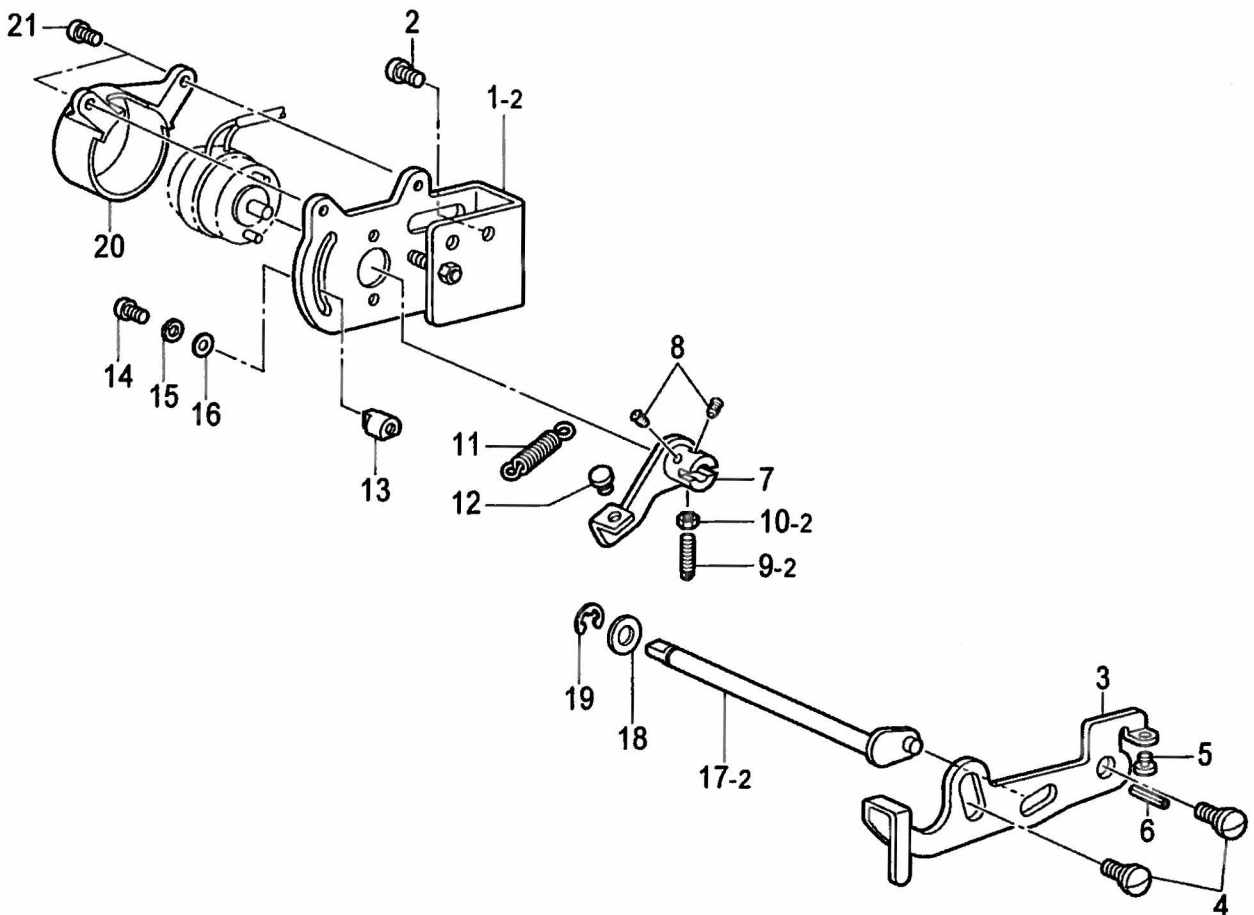

M. 糸取り関係 / Thread take-up mechanism

REF.NO	CODE	Q'TY	ヒンメイ	NAME OF PARTS	RM
			<KE-434C用>	<For KE-434C>	
1-1	S49659001	1	ソレノイドリツケイタ	SOLENOID SETTING PLATE	
2	062710812	2	ナベコ476-32X8	SCREW, PAN SM4.76-32X8	
3	S49660101	1	イトリレバー	THREAD TAKE-UP LEVER	
4	107321003	2	ダンネジ4.76	SHOULDER SCREW, SM4.76	
5	S19748001	1	サトウクランククッション	CUSHION	
6	047401442	1	スプリングピンAW4	PIN, SPRING ROLL AW4	
7	S49661101	1	ソレノイドツキテ		
8	S01998001	2	アタマツキメネジ3.57	SET SCREW, SM3.57-40X6	
9-1	110251001	2	ヌノオサエウデハネカケ	SPRING HOOK	
10-1	021670102	2	ナツト1シユ3.57	NUT, 1 SM3.57	
11	S34883001	1	イトキリハネ	SPRING, EXTENSION	
12	S19748001	1	サトウクランククッション	CUSHION	
13	S49663001	1	ナツト3.57	NUT, SM3.57	
14	062671012	1	ナベコ357-40X10	SCREW, PAN SM3.57-40X10	
15	028350242	1	ハネサガネ2-3.5	WASHER, SPRING 2-3.5	
16	025350332	1	ヒラサガネダ13.5	WASHER, PLAIN L 3.5	
17-1	S49662001	1	イトリレバークランク	TREAD TAKE-UP LEVER CRANK	
18	155559001	1	ヒラサガネ	WASHER, PLAIN	
19	048040342	1	トメワE4	RETAINING RING, E4	
20	S49664000	1	イトリソレノイドカバー	TREAD TAKE-UP SOLENOID COVER	
21	062670612	2	ナベコ357-40X6	SCREW, PAN SM3.57-40X6	
			<KE-435C用>	<For KE-435C>	
1-2	S55181001	1	ソレノイドリツケイタミ	SOLENOID SETTING PLATE ASSY	
2	062710812	2	ナベコ476-32X8	SCREW, PAN SM4.76-32X8	
3	S49660101	1	イトリレバー	THREAD TAKE-UP LEVER	
4	107321003	2	ダンネジ4.76	SHOULDER SCREW, SM4.76	
5	S19748001	1	サトウクランククッション	CUSHION	
6	047401442	1	スプリングピンAW4	PIN, SPRING ROLL AW4	
7	S49661101	1	ソレノイドツキテ		
8	S01998001	2	アタマツキメネジ3.57	SET SCREW, SM3.57-40X6	
9-2	110251001	1	ヌノオサエウデハネカケ	SPRING HOOK	
10-2	021670102	1	ナツト1シユ3.57	NUT, 1 SM3.57	
11	S34883001	1	イトキリハネ	SPRING, EXTENSION	
12	S19748001	1	サトウクランククッション	CUSHION	
13	S49663001	1	ナツト3.57	NUT, SM3.57	
14	062671012	1	ナベコ357-40X10	SCREW, PAN SM3.57-40X10	
15	028350242	1	ハネサガネ2-3.5	WASHER, SPRING 2-3.5	
16	025350332	1	ヒラサガネダ13.5	WASHER, PLAIN L 3.5	
17-2	S55111001	1	イトリレバークランク	T/TAKE-UP LEVER CRANK	
18	155559001	1	ヒラサガネ	WASHER, PLAIN	
19	048040342	1	トメワE4	RETAINING RING, E4	
20	S49664000	1	イトリソレノイドカバー	TREAD TAKE-UP SOLENOID COVER	
21	062670612	2	ナベコ357-40X6	SCREW, PAN SM3.57-40X6	

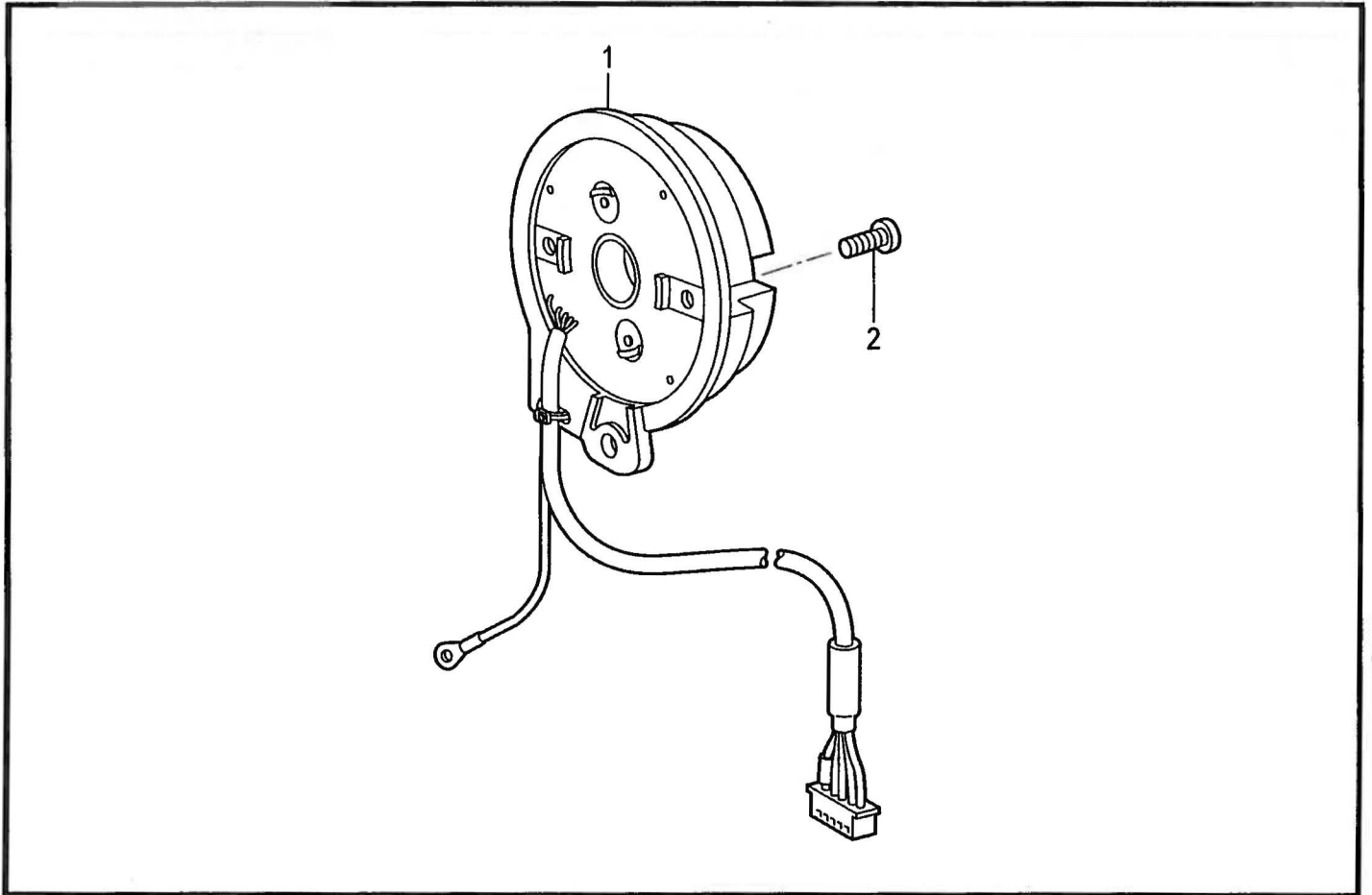

KE-434C/435C-501

P. プリント基板関係 / Printed circuit board mechanism

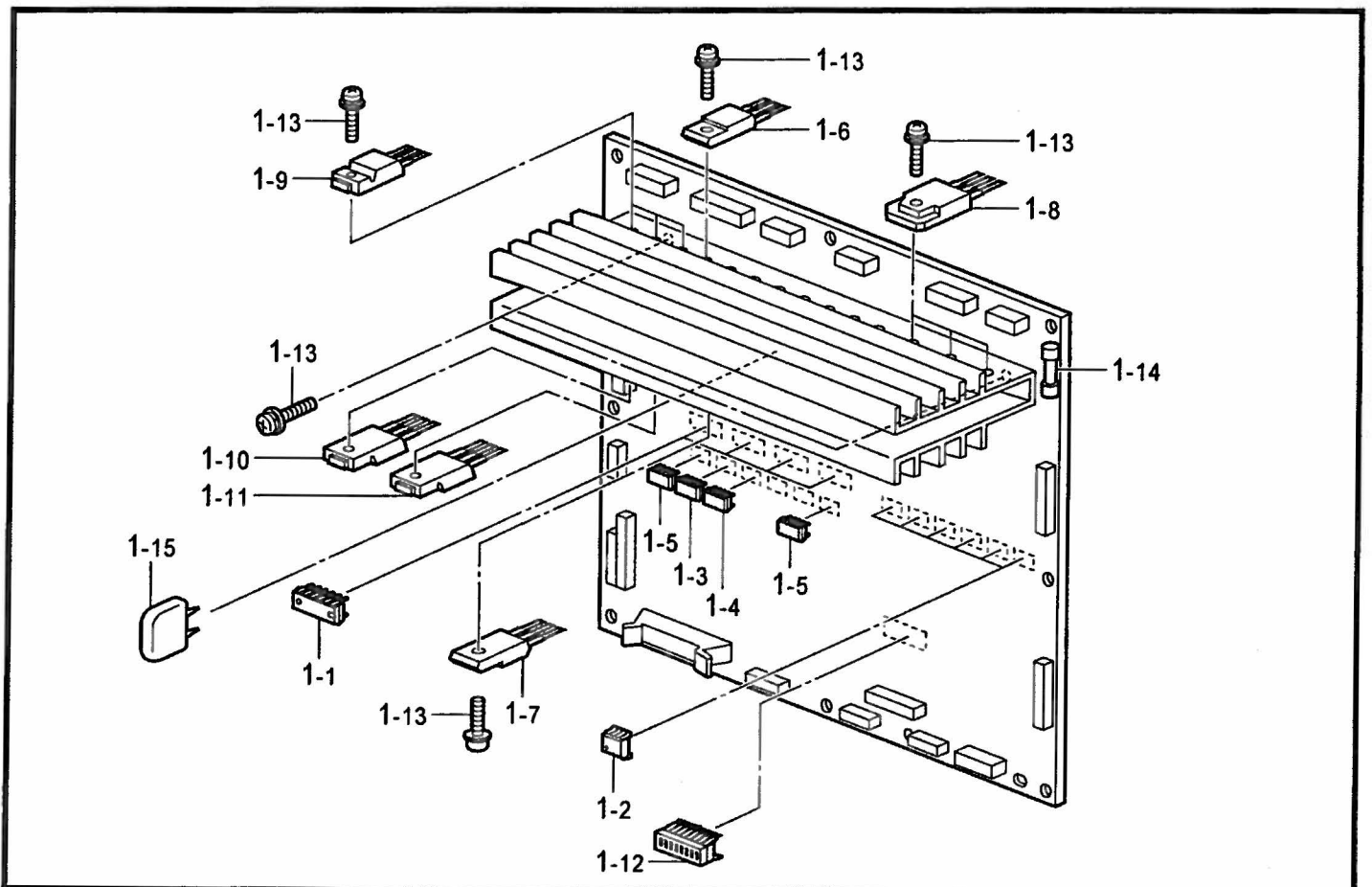

KE-434C/435C-518

N . 針位置検出器関係 / Synchronizer

REF.NO	CODE	Q'TY	ヒンメイ	NAME OF PARTS	RM
1	S48666001	1	シンクロナイザ'クミ	SYNCHRONIZER ASSY	
2	062400806	2	ナベ'コ4X8	SCREW, PAN M4X8	

KE-434C/435C-501

P . プリント基板関係 / Printed circuit board mechanism

REF.NO	CODE	Q'TY	ヒンメイ	NAME OF PARTS	RM
1	S49479001	1	メインキ'パンクミ	MAIN PCB ASSY	
1-1	S29019000	4	ICM54640P	IC:M54640P	
1-2	S43178000	6	PHカ'プ'ラPC9231	PHOTO COUPLER:PC9231	
1-3	093650008	1	IC74HC08FT	IC:74HC08F	
1-4	093650032	1	IC74HC32FT	IC:74HC32F	
1-5	091170009	2	IC:74LS09T	IC:74LS09F-T	
1-6	S49484000	8	MOSFETFS10KMJ-2	TRANSISTOR, FET:FS10KMJ-2	
1-7	SA3722001	8	MOSFETFX6KMJ-2	TRANSISTOR, FET:FX6KMJ-2	
1-8	S49471000	6	MOSFETFK18SM-12	TRANSISTOR, FET:FK18SM-12	
1-9	S38155000	3	MOSFET2SK1306	TRANSISTOR, FET:2SK1306	
1-10	S50645000	1	MOSFET2SK1307	TRANSISTOR, FET:2SK1307	
1-11	S49486000	1	MOSFET2SJ222	TRANSISTOR, FET:2SJ222	
1-12	U32744000	1	DIPSWDSS708	DIP SWITCH:DSS708	
1-13	0A4301005	31	ナベ'サ'クミ3X10DA	SCREW, PAN (S/P WASHER) M3X10	
1-14	S48578000	1	GFUSE5AFB'リ'ト'ツ'キ	GLASS FUSE, 5A W/LEED WIRE	
1-15	Y51030150	1	ホ'リC50B103	CAPACITOR, POLYESTER 50B103	

KE-434C/435C-518

Q1 . コントロールボックス関係 / Control box mechanism

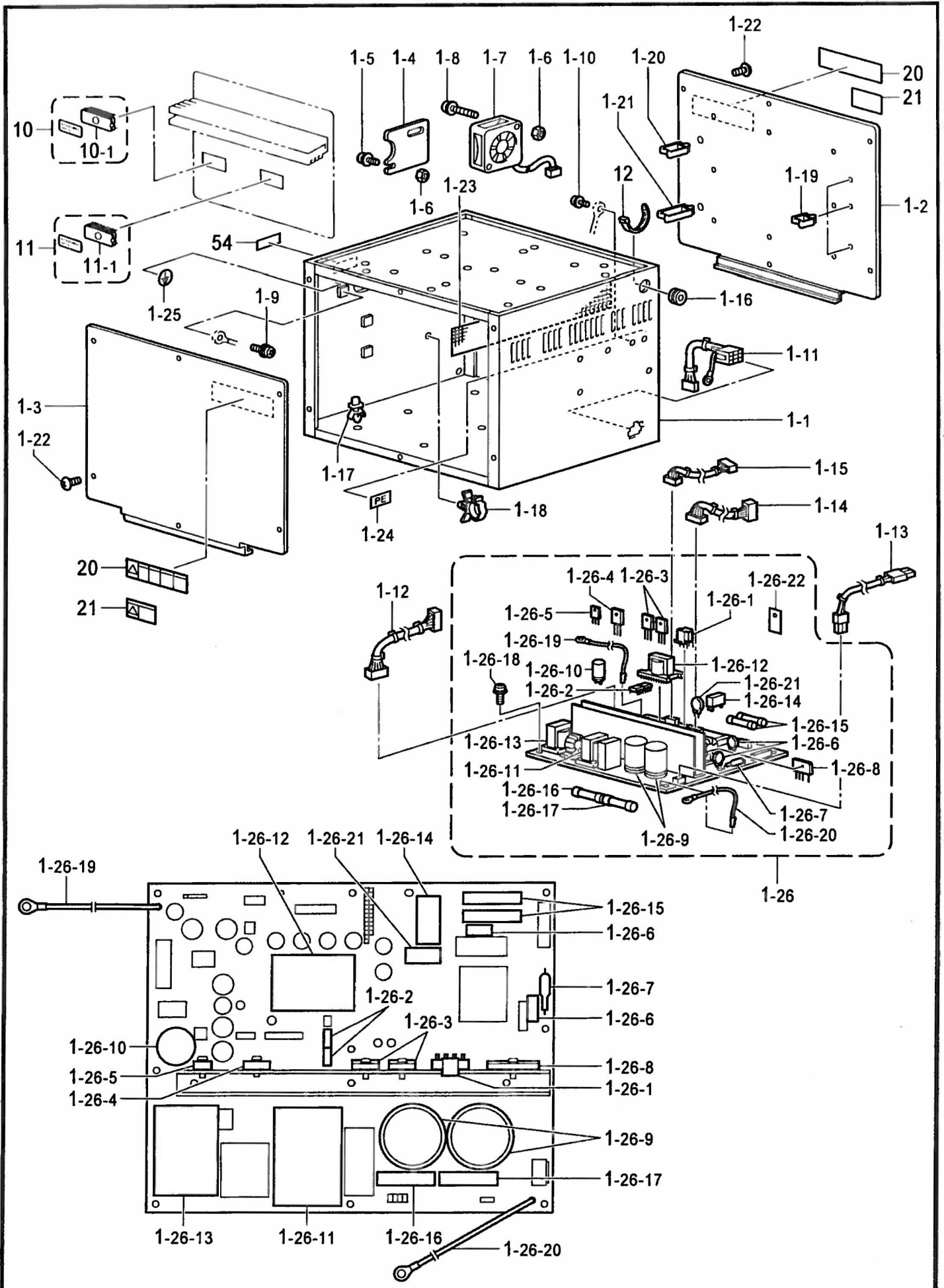

Q1 . コントロールボックス関係 / Control box mechanism

REF.NO	CODE	Q'TY	ヒンメイ	NAME OF PARTS	RM
1	S49467001	1	ボックス	BOX ASSY	
1-1	S49468001	1	デンケンボックス	POWER SUPPLY BOX	
1-2	S49469001	1	メイン基板トリツケ	MAIN PCB SETTING PLATE	
1-3	S49470001	1	ボックス	BOX COVER	
1-4	S38093000	1	コート	HOLDER PLATE	
1-5	0A5401206	2	ナット	SCREW, PAN (S/P WASHER) M4X12	
1-6	021400206	2	ナット	NUT, 2 M4	
1-7	S47692000	1	DCファン	FAN MOTOR ASSY, DC	
1-8	0A5403006	2	ナット	SCREW, PAN (S/P WASHER) M4X30	
1-9	0A5400806	1	ナット	SCREW, PAN (S/P WASHER) M4X8	
1-10	0A5401206	2	ナット	SCREW, PAN (S/P WASHER) M4X12	
1-11	S42260000	1	フットSW	FOOT SWITCH HARNESS ASSY, 434	
1-12	S38107100	1	セイキョ	CONTROL POWER SUPPLY HARNESS	
1-13	S38108000	1	モータ	MOTOR POWER SUPPLY HARNESS	
1-14	S38109100	1	ゲート	H-P POWER SUPPLY HARNESS	
1-15	S38110000	1	PER	POWER HARNESS	
1-16	S11949000	1	ゴム	RUBBER BUSH	
1-17	S00554000	17	サポ	SUPPORT, 6NS	
1-18	S31760000	2	CKS	CORD CLAMP, 26-L	
1-19	S43275000	6	コード	CORD CLAMP, WS2NS	
1-20	S43276000	4	コード	CORD CLAMP, WS3NS	
1-21	S43277000	1	コード	CORD CLAMP, WS4NS	
1-22	008400604	12	トラス	SCREW, TRUSS M4X6	
1-23	S38116000	1	ホウ	FRAGMENT PROTECTOR NET	
1-24	S37059001	1	PE	LABEL, PE	
1-25	S37060001	1	ア	LABEL, GROUNDING	
1-26	S49939101	1	デンケン	POWER SUPPLY PCB ASSY	
1-26-1	S43177000	1	MA3830	IC :MA3830	
1-26-2	S43184000	2	PH	PHOTO COUPLER :PC923	
1-26-3	S49586000	2	MOSFET	TRANSISTOR, FET :2SK1941	
1-26-4	S55473000	1	SIDPA	DIODE, AR :PA905C6-F	
1-26-5	S38203000	1	SBDYG	DIODE :YG8022C04R	
1-26-6	SA0037000	2	バリ	VARISTOR:V14D511	
1-26-7	232384001	1	Sア	SURGE ABSORBER :DSA362MA	
1-26-8	S49071000	1	DBRD	DIODE BRIDGE :25XB60	
1-26-9	S38205000	2	デン	CAPACITOR, ALUM-ELEC 250B182	
1-26-10	SA1034000	1	デン	CAPACITOR, ALUM-ELEC 63B562	
1-26-11	S43175000	1	トランス	TRANSFORMER :54AA159	
1-26-12	S43176000	1	トランス	TRANSFORMER :35AD199	
1-26-13	S43181000	1	コイル	COIL :49AD289AC	
1-26-14	S38208000	1	RYJW	RELAY :JW1AFSN/DC 5V	
1-26-15	153242000	2	ヒュー	FUSE, 6A	
1-26-16	S08030000	1	ヒュー	FUSE, 5A :FB	
1-26-17	S48580000	1	GFUSE	FUSE, 7A :FB	
1-26-18	0A4301005	8	ナット	SCREW, PAN (S/P WASHER) M3X10	
1-26-19	S43189000	1	PCBE1	PCB E1 HARNESS	
1-26-20	S43187000	1	PCBE2	PCB E2 HARNESS	
1-26-21	S49472000	1	サー	THERMISTOR :6D-22	
1-26-22	S49938000	1	ゼツ	INSULATION SHEET	
10	S49477000	1	PROM	PROM CONTROL ASSY	
10-1	UA4817000	1	MOSLSI	EPROM:27C2001	
11	S49478000	1	PROM	PROM MOTOR ASSY	
11-1	S38143000	1	CM0SLSI	LSI:27C512	
12	228475000	1	ケツ	TYING BAND 1.9X80	

KE-434C/435C-502

RM欄に*が付いている部品をご注文いただきますと、基板等必要な部品が一式入ったセットになっています。
When ordering parts which have an (*) in the RM column, these parts will be supplied as a set together with other necessary parts such as circuit boards.

Q1. コントロールボックス関係 / Control box mechanism

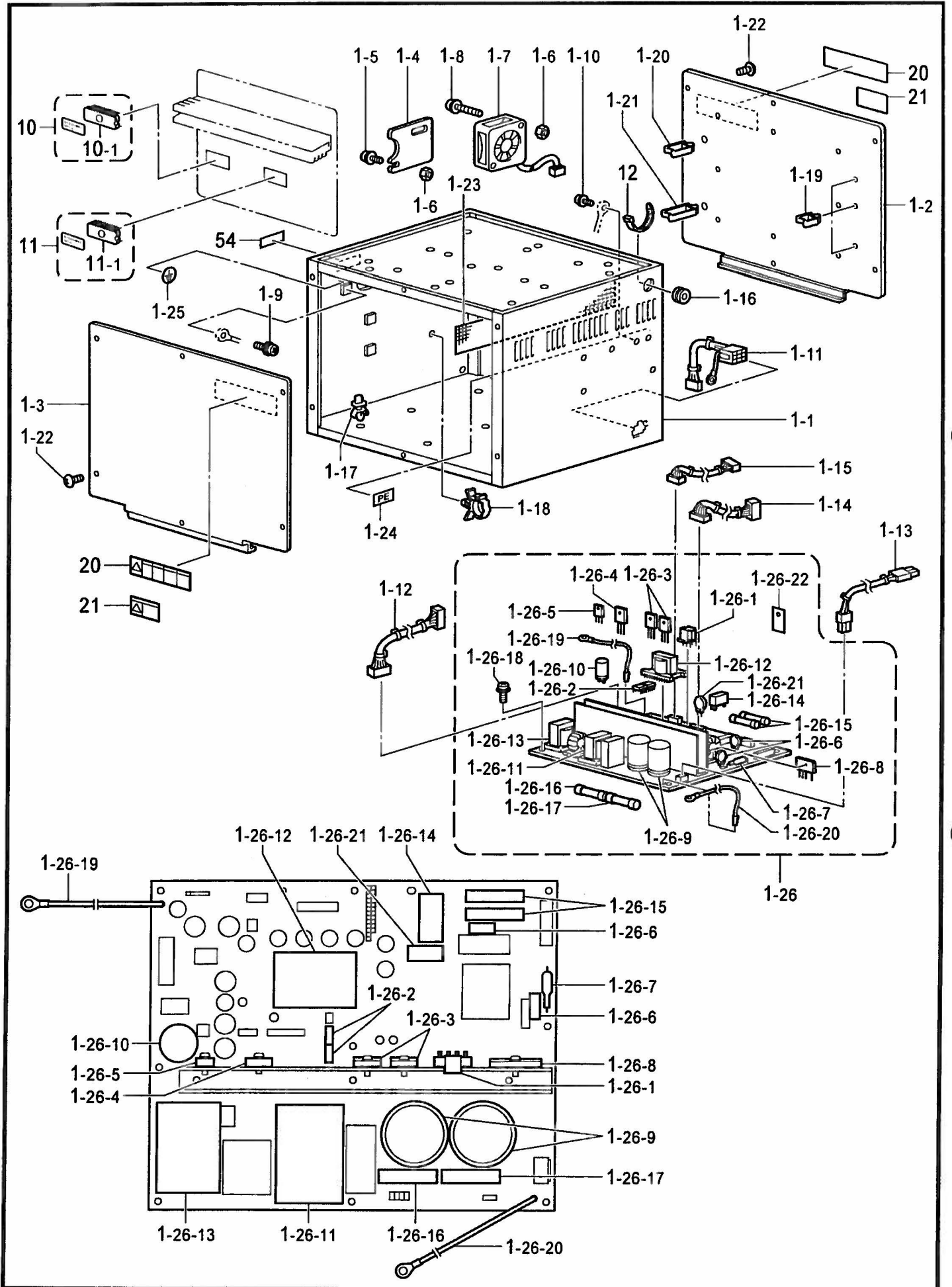

Q1 . コントロールボックス関係 / Control box mechanism

REF.NO	CODE	Q'TY	ヒンメイ	NAME OF PARTS	RM
20	S38352101	2	<輸出用> デンゲキラベル.4カコク	<For Export> LABEL, ELEC. SHOCK 4 LANG.	
21	S38353101	2	<国内向用> デンゲキラベル.ワ	<For Japan only>	
54	S55627001	1	IMラベル	IM LABEL	
H-1	S53031001	1	" 補給用部品 " <三相200V、220V用> ボックスソウクミA1-IM	" For Supply parts " <For "3-Phase 200V & 220V AC"> BOX UNIT, A1-IM	*
H-2	S53033001	1	<単相200V、230V用> ボックスソウクミA2-IM	<For "1-Phase 200V & 230V AC"> BOX UNIT, A2-IM :1-P. 220/230V	*
H-3	S53034001	1	<単相100V用> ボックスソウクミB1-IM	<For Japan only>	*
H-4	S53035001	1	<単相110V、120V用> ボックスソウクミB2-IM	<For "1-Phase 110V & 120V AC"> BOX UNIT, B2-IM :1-P. 110V AC	*
H-5	S53036001	1	<三相415V用> ボックスソウクミC1-IM	<For "3-Phase 415V AC"> BOX UNIT, C1-IM :3-P. 415V AC	*
H-6	S53037001	1	<三相380V用> ボックスソウクミC2-IM	<For "3-Phase 380V AC"> BOX UNIT, C2-IM :3-P. 380V AC	*
H-7	S53038001	1	<単相240V用> ボックスソウクミC3-IM	<For "1-Phase 240V AC"> BOX UNIT, C3-IM :1-P. 240V AC	*
H-8	S53039001	1	<三相400V用> ボックスソウクミE-IM	<For "3-Phase 400V AC"> BOX UNIT, E-IM :3-P. 400V AC	*
H-9	S53040001	1	<単相230V用> ボックスソウクミF-IM	<For "1-Phase 230V AC"> BOX UNIT, F-IM :1-P. 230V AC	*

KE-434C/435C-502

RM欄に*が付いている部品をご注文いただきますと、基板等必要な部品が一式入ったセットになっています。
When ordering parts which have an (*) in the RM colum, these parts will be supplied as aset together with other neccsary parts such as sucuit boards.

< 三相200V,220V用 / For "3-Phase 200V & 220V AC" >

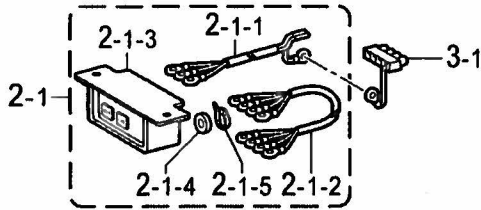

< 単相220V,230V用 / For "1-Phase 220V & 230V AC" >

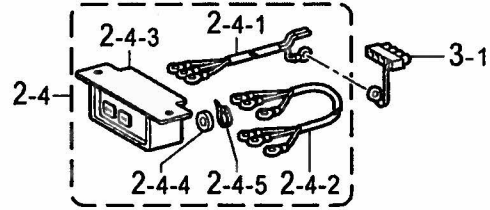

< 単相100V用 / For Japan only >

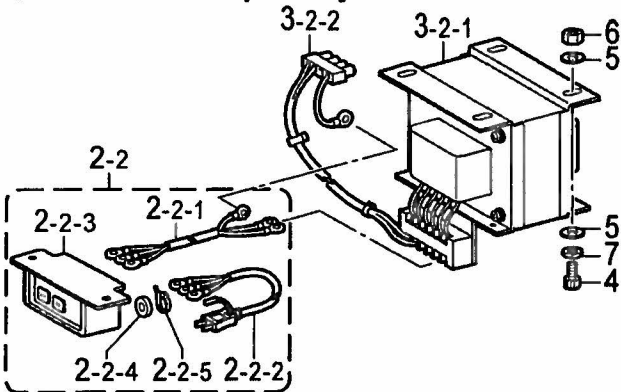

< 単相110V,120V用 / For "1-Phase 110V & 120V AC" >

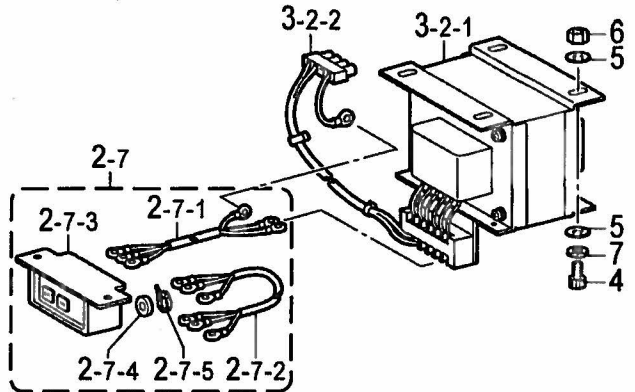

< 三相415V,380V用 / For "3-Phase 415V & 380V AC" >

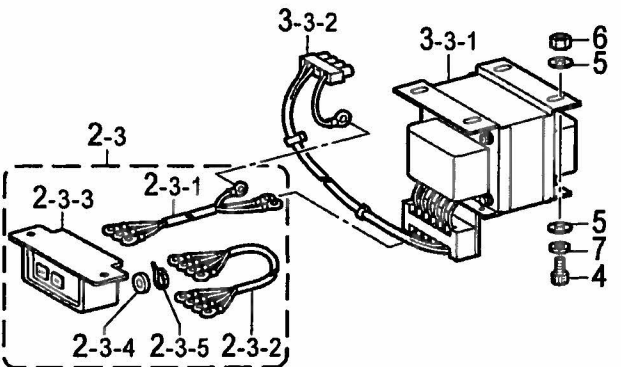

< 単相240V用 / For "1-Phase 240V AC" >

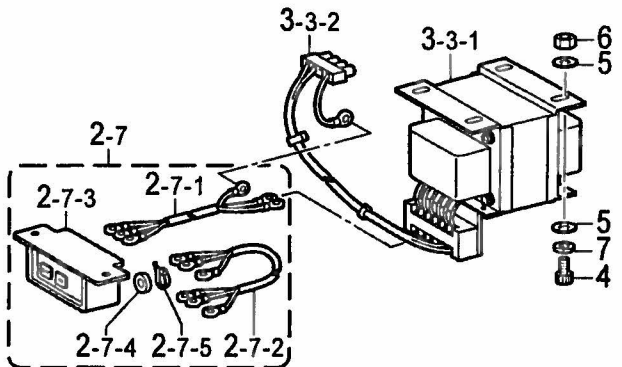

" オプション部品 / OPTION PARTS "

< 三相400V / For "3-Phase 400V AC" >

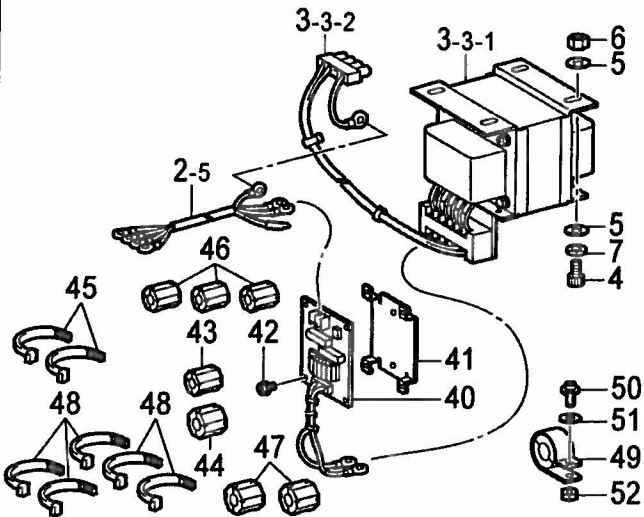

< 単相230V / For "1-Phase 230V AC" >

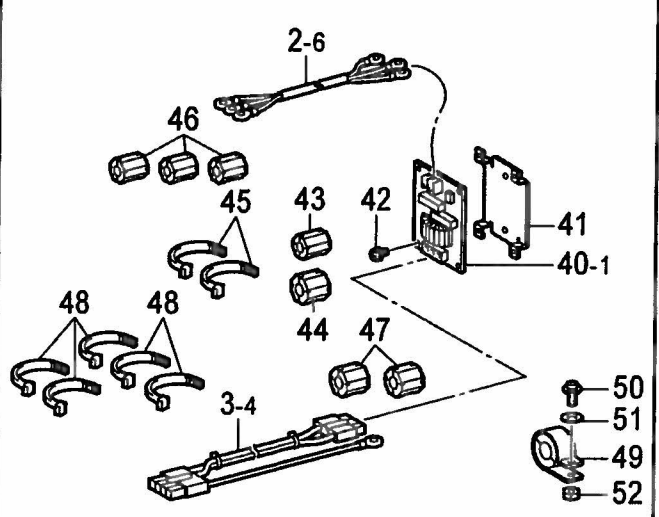

Q2 . コントロールボックス関係 / Control box mechanism

REF.NO	CODE	Q'TY	ヒンメイ	NAME OF PARTS	RM
			<三相200V、220V用>	<For "3-Phase 200V & 220V AC">	
2-1	S38112001	1	デンゲンSWクミA	POWER SUPPLY SWITCH ASSY, A	
2-1-1	S38113000	1	デンゲンINコードA	POWER SUPPLY IN HARNESS, A	
2-1-2	S38133000	1	デンゲンコード	POWER SUPPLY HARNESS	
2-1-3	J02657001	1	3PオシSW#17	3P. PUSH SWITCH, #17	
2-1-4	224514001	2	セツエンイタ	INSULATION PLATE	
2-1-5	218859001	2	バインダM150	BINDER, M150	
			<単相100V用>	<For Japan only>	
2-2	S38114000	1	デンゲンSWクミB	_____	
2-2-1	S38115000	1	デンゲンINコードB	_____	
2-2-2	S38118000	1	デンゲンコードコナイ	_____	
2-2-3	J02657001	1	3PオシSW#17	_____	
2-2-4	224514001	2	セツエンイタ	_____	
2-2-5	218859001	2	バインダM150	_____	
			<三相415V、380V用>	<For "3-Phase 415V & 380V AC">	
2-3	S38117000	1	デンゲンSWクミC	POWER SUPPLY SWITCH ASSY, C	
2-3-1	S38115000	1	デンゲンINコードB	POWER SUPPLY IN HARNESS, B	
2-3-2	S38133000	1	デンゲンコード	POWER SUPPLY HARNESS	
2-3-3	J02657001	1	3PオシSW#17	3P. PUSH SWITCH, #17	
2-3-4	224514001	2	セツエンイタ	INSULATION PLATE	
2-3-5	218859001	2	バインダM150	BINDER, M150	
			<単相200V、230V用>	<For "1-Phase 200V & 230V AC">	
2-4	S47592000	1	デンゲンSWクミD	POWER SUPPLY SWITCH ASSY, D	
2-4-1	S38113000	1	デンゲンINコードA	POWER SUPPLY IN HARNESS, A	
2-4-2	S47595000	1	デンゲンコードユシュツ	POWER SUPPLY HARNESS, EXP.	
2-4-3	J02657001	1	3PオシSW#17	3P. PUSH SWITCH, #17	
2-4-4	224514001	2	セツエンイタ	INSULATION PLATE	
2-4-5	218859001	2	バインダM150	BINDER, M150	
			" オプション部品 "	" OPTION PARTS "	
			<三相400V用>	<For "3-Phase 400V AC">	
2-5	S38120000	1	デンゲンINコードE	POWER SUPPLY IN HARNESS, E	
			<単相230V用>	<For "1-Phase 230V AC">	
2-6	S43188000	1	デンゲンINコードF	POWER SUPPLY IN HARNESS, F	
			<単相110V、120V、240V用>	<For "1-Phase 110V, 120V & 240V AC">	
2-7	S47594000	1	デンゲンSWクミG	POWER SUPPLY SWITCH ASSY, G	
2-7-1	S38115000	1	デンゲンINコードB	POWER SUPPLY IN HARNESS, B	
2-7-2	S47595000	1	デンゲンコードユシュツ	POWER SUPPLY HARNESS, EXP.	
2-7-3	J02657001	1	3PオシSW#17	3P. PUSH SWITCH, #17	
2-7-4	224514001	2	セツエンイタ	INSULATION PLATE	
2-7-5	218859001	2	バインダM150	BINDER, M150	
			<単相220V、230V 三相200V、220V用>	<For "1-Phase 220V & 230V AC 3-Phase 200V & 220V AC">	
3-1	S38123000	1	ACINコネクタミ	AC-IN CONNECTOR ASSY	
			<単相100V、110V、120V用>	<For "1-Phase 100V, 110V & 120V AC">	
3-2	S49473000	1	ハンカトランスBクミ	CONVERSION TRANSFORMER ASSY, B	
3-2-1	S49474000	1	ハンカトランスB	CONVERSION TRANSFORMER, B	
3-2-2	S38126000	1	ACINコード	AC-IN HARNESS	

< 三相200V,220V用 / For "3-Phase 200V & 220V AC" >

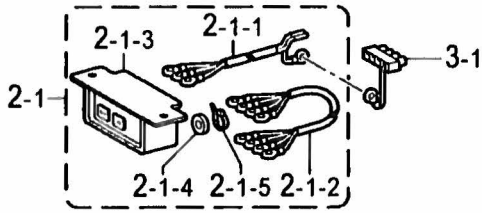

< 単相220V,230V用 / For "1-Phase 220V & 230V AC" >

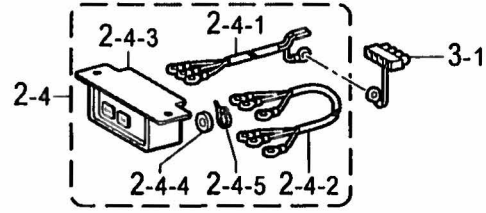

< 単相100V用 / For Japan only >

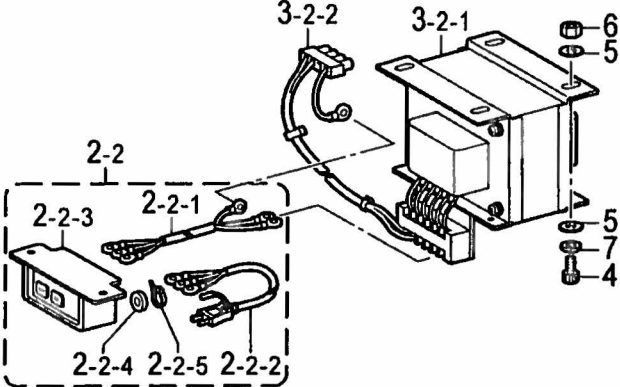

< 単相110V,120V用 / For "1-Phase 110V & 120V AC" >

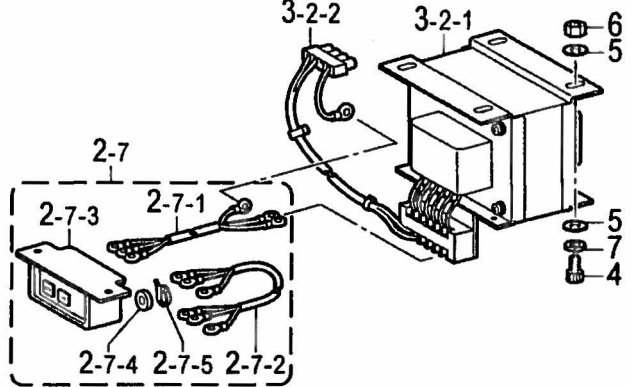

< 三相415V,380V用 / For "3-Phase 415V & 380V AC" >

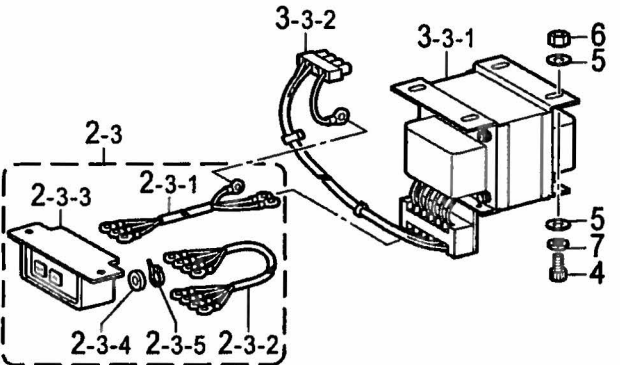

< 単相240V用 / For "1-Phase 240V AC" >

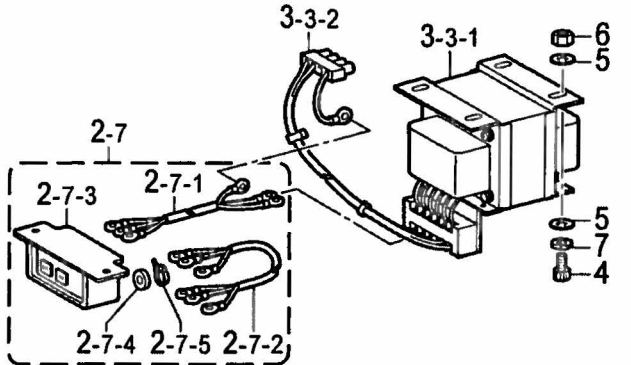

" オプション部品 / OPTION PARTS "

< 三相400V / For "3-Phase 400V AC" >

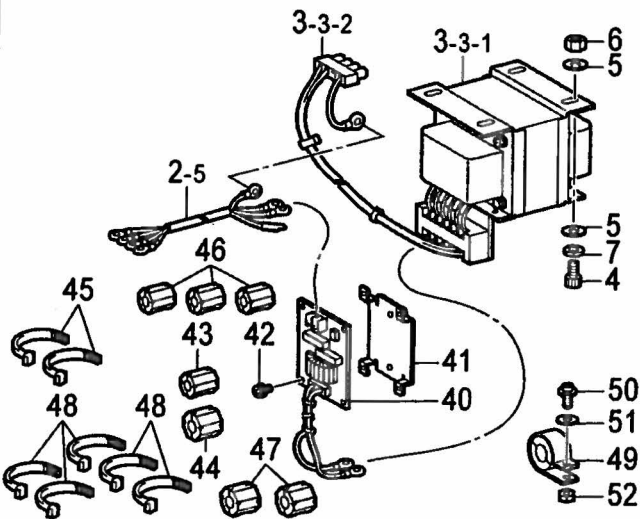

< 単相230V / For "1-Phase 230V AC" >

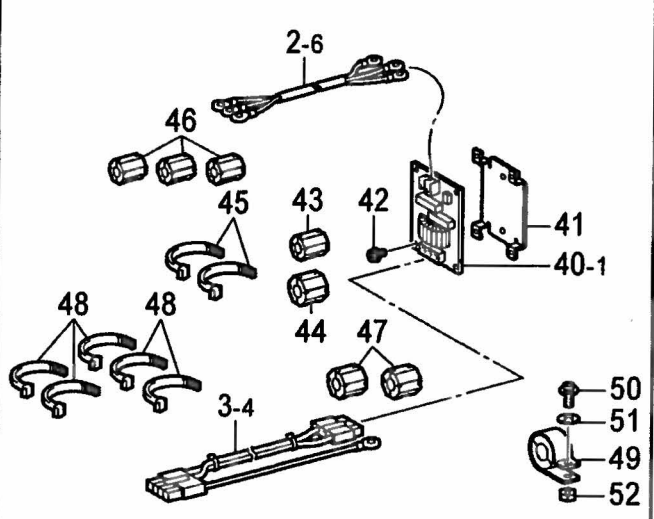

Q2 . コントロールボックス関係 / Control box mechanism

REF.NO	CODE	Q'TY	ヒンメイ	NAME OF PARTS	RM
3-3	S49475000	1	<単相240V 三相400V、415V、380V用>	<For "1-Phase 240V AC 3-Phse 400V, 415V & 380V AC">	
3-3-1	S49476000	1	ハンカトランスC	CONVERSION TRANSFORMER ASSY, C	
3-3-2	S38126000	1	ハンカトランスC	CONVERSION TRANSFORMER, C	
			ACINコード	AC-IN HARNESS	
3-4	S43201000	1	" オプション部品 " <単相230V用>	" OPTION PARTS " <For "1-Phase 230V AC">	
			ACINコードF	AC-IN HARNESS, F	
4	018061436	4	<単相200V, 220V, 230V以外> アナホルト6X14	<Except for "200V, 220V & 230V AC"> BOLT, SOCKET M6X14	
5	025060236	8	ヒラザガネチユウ6	WASHER, PLAIN M 6	
6	021060106	4	1シユナツ6	NUT, 1 M6	
7	028060246	4	ハネザガネ2-6	WASHER, SPRING 2-6	
40	S40635001	1	" オプション部品 " <三相400V用>	" OPTION PARTS " <For "3-Phase 400V AC">	
			ノイズフィルタ430E	NOISE FILTER ASSY, 430E	
40-1	S40616001	1	<単相230V用>	<For "1-Phase 230V AC">	
			ノイズフィルタEMC	NOISE FILTER ASSY, EMC	
41	S40620000	1	<単相230V, 三相400V用>	<For "1-Phase 230V AC & 3-Phase 400V AC">	
42	0A4400605	6	キハントリツケイタ	PCB SETTING PLATE	
43	S40621000	1	ナベザクミ4X6DA	SCREW, PAN (S/P WASHER) M4X6	
44	S40622000	1	EMIコアESD-SR-15	EMI CORE, ESD-SR-15	
45	149809000	2	EMIコアESD-SR-25	EMI CORE, ESD-SR-25	
46	S40621000	3	タイラツPL	BEAD BAND, L=200	
47	S40622000	2	EMIコアESD-SR-15	EMI CORE, ESD-SR-15	
48	149809000	2	EMIコアESD-SR-25	EMI CORE, ESD-SR-25	
49	S40623000	5	タイラツPL	BEAD BAND, L=200	
50	0A5401606	1	EMIコアTR-40-27	EMI CORE, TR-40-27	
51	025040236	1	ナベザクミ4X16DB	SCREW, PAN (S/P WASHER) M4X16	
52	021400106	1	ヒラザガネチユウ4	WASHER, PLAIN M 4	
			ナツト1シユ4	NUT, 1 M4	

" オプション部品 / OPTION PARTS "

< エアー式ソフト押工用
/ For soft work clamp of Pneumatic type >

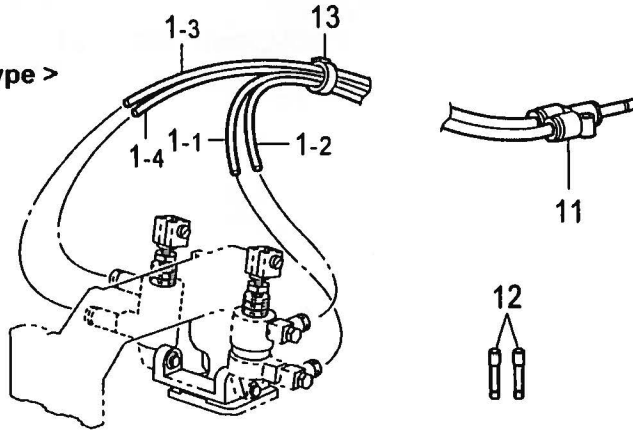

< エアー式用 / For Pneumatic type >

500

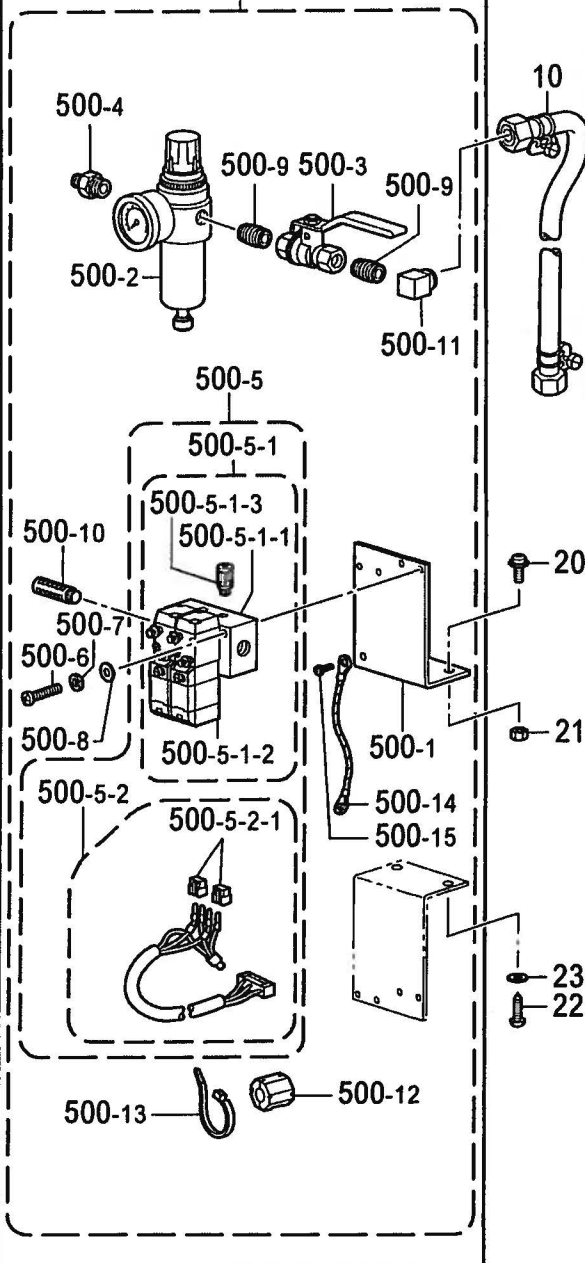

< 反転用 / For Inner clamping device >

600

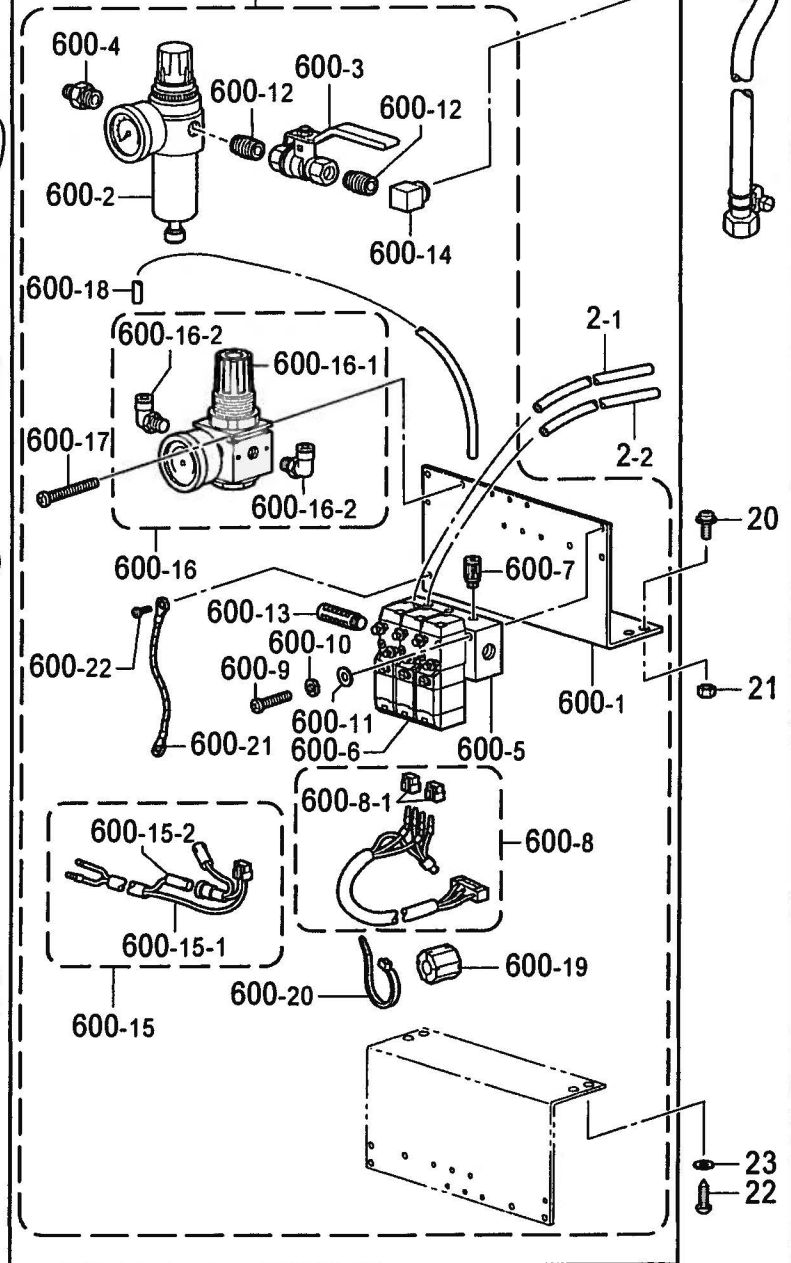

R1 . 空圧関係 (KE-434C) / Air pressure mechanism (KE-434C)

REF.NO	CODE	Q'TY	ヒンメイ	NAME OF PARTS	RM
			“ オプション部品 ” ＜エア一式ソフト押工用＞	“ OPTION PARTS ” ＜For Soft work clamp of pneumatic type＞	
1-1	S43687001	1	ナイロンチューブR	AIR TUBE, R	
1-2	S43687002	1	ナイロンチューブR	AIR TUBE, R	
1-3	S43688001	1	ナイロンチューブL	AIR TUBE, L	
1-4	S43688002	1	ナイロンチューブL	AIR TUBE, L	
11	S08178000	2	フランジUY-4	BRANCH, UY-4	
12	S04897000	2	プラグ4	PLUG, 4	
13	228475000	3	ケツソクバンド1.9X80	TYING BAND 1.9X80	
			＜エア一式用＞	＜For Pneumatic type＞	
10	149796001	1	ゴムホースカナグツキ	AIR HOSE, W/CONNECTOR	
20	0A5501205	2	+ナヘサグミ5X12DB	SCREW, PAN (S/P WASHER) M5X12	
21	021500106	2	1シュナツト5	NUT, 1 M5	
22	032422003	2	+マルモクネジ4.1X20	WOOD SCREW, ROUND M4.1X20	
23	148847001	2	サガネ	WASHER, PLAIN 4.76	
500	S55424001	1	デンジバルブ2Aクミ	SOLENOID VALVE 2A ASSY	
500-1	S31551209	1	バルブトリツケイタ2-3	SETTING PLATE, 2-3 :VALVE	
500-2	S09318101	1	インテグレータ	INTEGRATOR	
500-3	S40628000	1	ボールバルブ1/4	BALL VALVE, 1/4	
500-4	S09228000	1	イケニツプル	NIPPLE, 1/4X1/8	
500-5	S43679101	1	デンジバルブ2クミ	SOLENOID VALVE ASSY, 2	
500-5-1	S43680001	1	エアマニホルドクミ	AIR MANIFOLD ASSY	
500-5-1-1	S43684001	1	エアマニホルド	AIR MANIFOLD	
500-5-1-2	S43683001	2	デンジバルブ	SOLENOID VALVE	
500-5-1-3	S18415101	4	ハーフユニオンQ4M5	HALF UNION :Q4M5	
500-5-2	S43682100	1	バルブハーネスX2クミ	VALVE HARNESS ASSY, X2	
500-5-2-1	S12404000	2	クロダバルブコネクタ	VALVE CONNECTOR	
500-6	062302506	2	ナヘコ3X25	SCREW, PAN M3X25	
500-7	028030242	2	ハネサガネ2-3	WASHER, SPRING 2-3	
500-8	025030232	2	ヒラサガネチユウ3	WASHER, PLAIN M 3	
500-9	S40629000	2	ハレルニツプル	BARREL NIPPLE	
500-10	S23880000	2	エアマフラー	AIR MUFFLER	
500-11	S43686000	1	PTエルボ1/4	ELBOW, PT 1/4	
500-12	S40622000	1	EMコアESD-SR-25	EMI CORE, ESD-SR-25	
500-13	149809000	1	タイラツプル	BEAD BAND, L=200	
500-14	S44287000	1	アースセン1050	GROUND WIRE, 1050	
500-15	0A5400806	1	+ナヘサグミ4X8DB	SCREW, PAN (S/P WASHER) M4X8	
			＜反転用＞	＜For Inner clamping device＞	
2-1	S53118001	1	ナイロンチューブ	AIR TUBE, RV-3A L=1600	
2-2	S53118002	1	ナイロンチューブ	AIR TUBE, RV-3B L=1600	
10	149796001	1	ゴムホースカナグツキ	AIR HOSE, W/CONNECTOR	
20	0A5501205	2	+ナヘサグミ5X12DB	SCREW, PAN (S/P WASHER) M5X12	
21	021500106	2	1シュナツト5	NUT, 1 M5	
22	032422003	2	+マルモクネジ4.1X20	WOOD SCREW, ROUND M4.1X20	
23	148847001	2	サガネ	WASHER, PLAIN 4.76	
600	S51855209	1	ハンデンバルブ3Aクミ	REVERSE VALVE ASSY, 3A	
600-1	S31570409	1	バルブトリツケイタ4-5H	VALVE SETTING PLATE, 4-5H	
600-2	S09318101	1	インテグレータ	INTEGRATOR	
600-3	S40628000	1	ボールバルブ1/4	BALL VALVE, 1/4	
600-4	S09228000	1	イケニツプル	NIPPLE, 1/4X1/8	
600-5	S44748001	1	エアマニホルド3	AIR MANIFOLD, 3	
600-6	S43683001	3	デンジバルブ	SOLENOID VALVE	
600-7	S18415101	6	ハーフユニオンQ4M5	HALF UNION :Q4M5	
600-8	S43682100	1	バルブハーネスX2クミ	VALVE HARNESS ASSY, X2	
600-8-1	S12404000	2	クロダバルブコネクタ	VALVE CONNECTOR	
600-9	062302506	2	ナヘコ3X25	SCREW, PAN M3X25	
600-10	028030242	2	ハネサガネ2-3	WASHER, SPRING 2-3	

" オプション部品 / OPTION PARTS "

< エア式ソフト押工用
/ For soft work clamp of Pneumatic type >

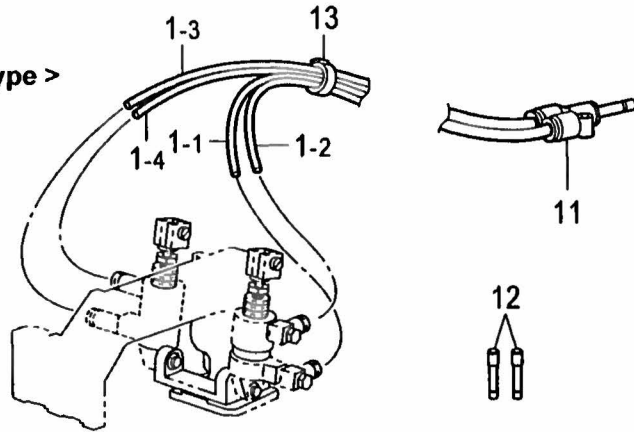

< エア式用 / For Pneumatic type >

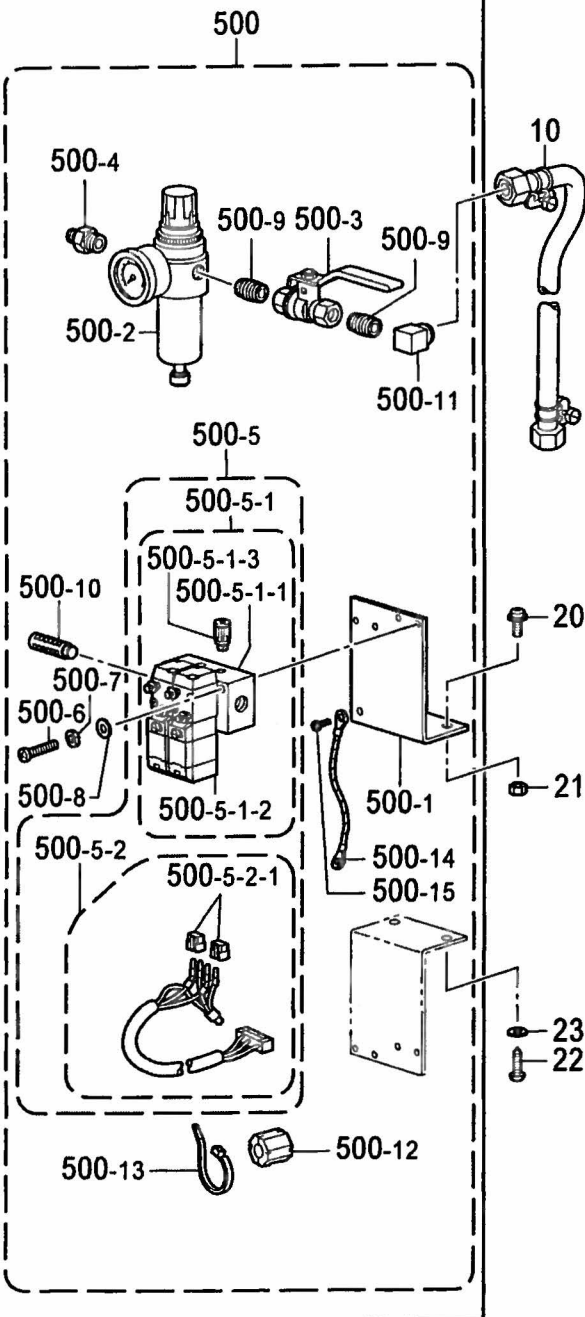

< 反転用 / For Inner clamping device >

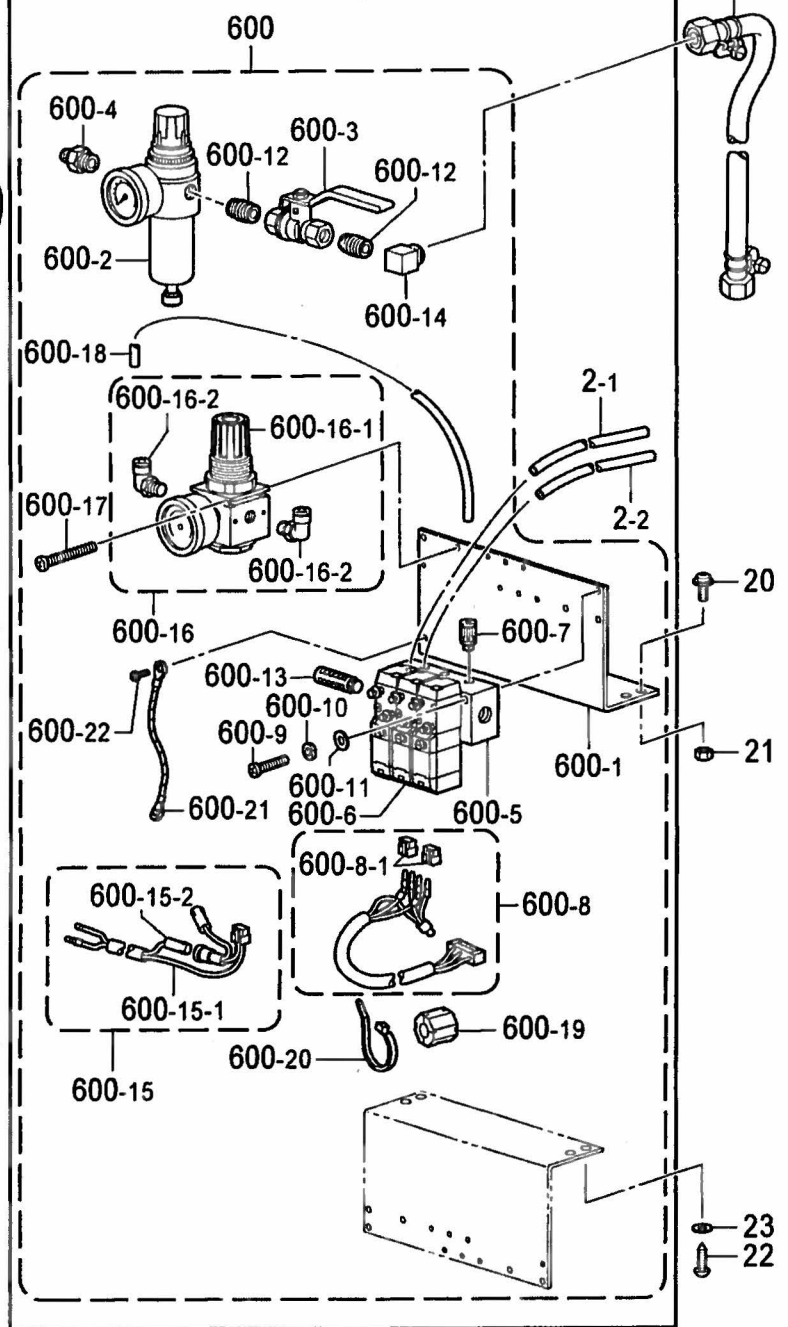

R1 . 空圧関係 (KE-434C) / Air pressure mechanism (KE-434C)

REF.NO	CODE	Q'TY	品名	NAME OF PARTS	RM
			<反転用>	<For Inner clamping device>	
600-11	025030232	2	ヒラサガネチユウ3	WASHER, PLAIN M 3	
600-12	S40629000	2	ハレルニツプル	BARREL NIPPLE	
600-13	S23880000	2	エアマフラー	AIR MUFFLER	
600-14	S43686000	1	PTエルボ1/4	ELBOW, PT 1/4	
600-15	S43696100	1	バルブハーネスX1クミ	VALVE HARNESS ASSY, X1	
600-15-1	S44746100	1	ツイカバルブハーネス	VALVE HARNESS	
600-15-2	S44750100	1	ツイカバルブハーネス24V	VALVE HARNESS, 24V	
600-16	S45252000	1	レギュレータクミ	REGULATOR ASSY	
600-16-1	S45253000	1	レギュレータ	REGULATOR	
600-16-2	S45254000	2	ツギテ3109-4-10	JOINT, 3109-4-10	
600-17	062404005	2	ナベコ4X40	SCREW, PAN M4X40	
600-18	S28741000	1	エアチューブ	AIR TUBE, 4 L=300	
600-19	S40622000	1	EMIコアESD-SR-25	EMI CORE, ESD-SR-25	
600-20	149809000	1	タイラツプル	BEAD BAND, L=200	
600-21	S44287000	1	アースセン1050	GROUND WIRE, 1050	
600-22	0A5400806	1	+ナベサクミ4X8DB	SCREW, PAN (S/P WASHER) M4X8	

" オプション部品 / OPTION PARTS "

< エアー式ソフト押工用
/ For soft work clamp of Pneumatic type >

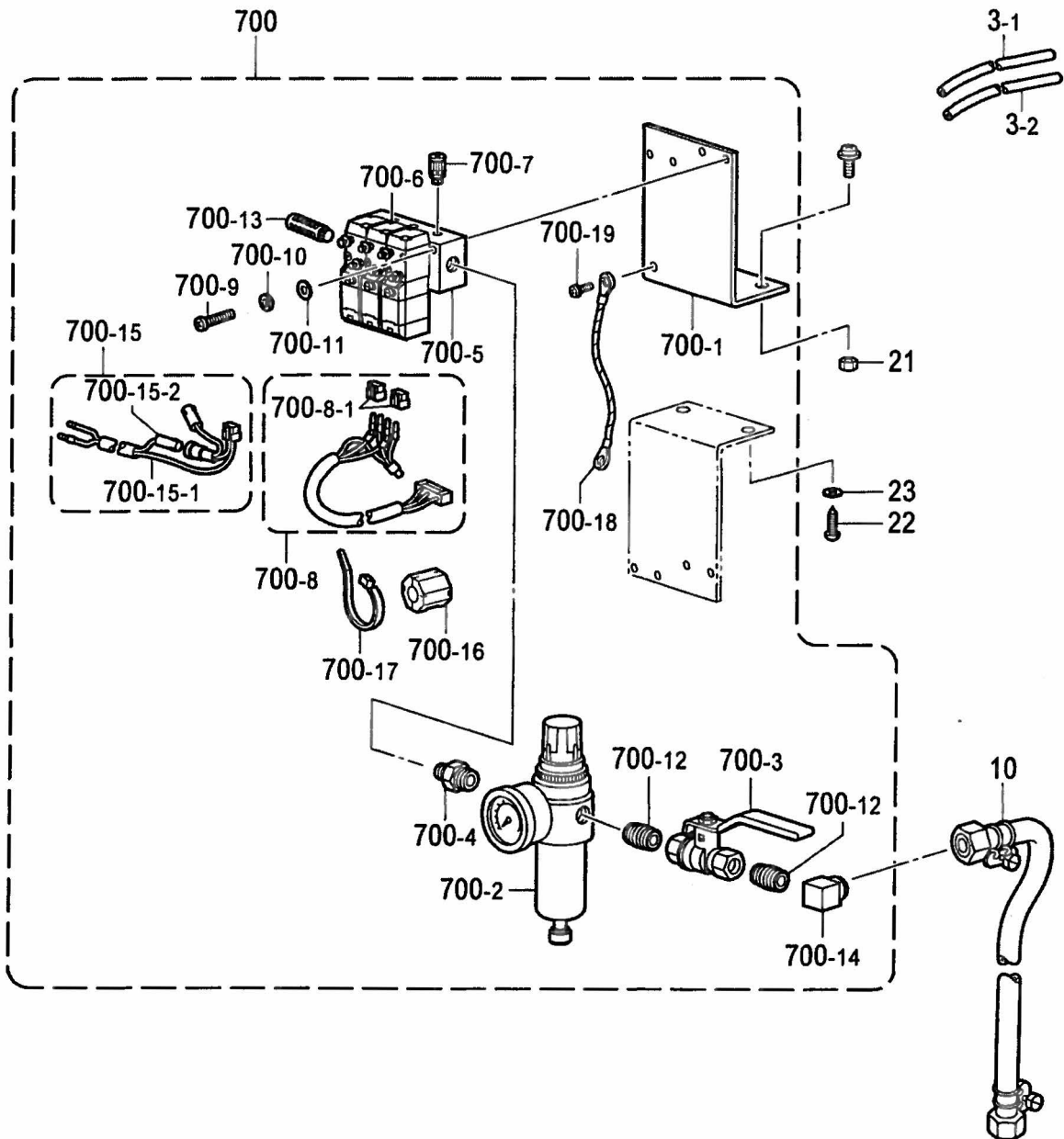
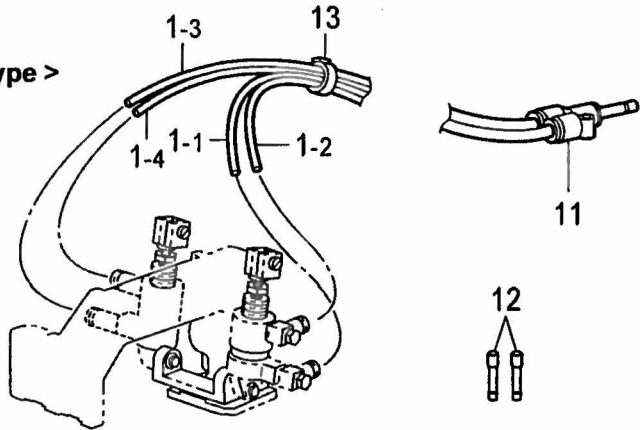

R2 . 空圧関係 (KE-435C) / Air pressure mechanism (KE-435C)

REF.NO	CODE	Q'TY	ヒンメイ	NAME OF PARTS	RM
			" オプション部品 " <エア一式ソフト押工用>	" OPTION PARTS " <For Soft work clamp of pneumatic type>	
1-1	S43687001	1	ナイロンチューブR	AIR TUBE, R	
1-2	S43687002	1	ナイロンチューブR	AIR TUBE, R	
1-3	S43688001	1	ナイロンチューブL	AIR TUBE, L	
1-4	S43688002	1	ナイロンチューブL	AIR TUBE, L	
10	149796001	1	ゴムホースカナグツキ	AIR HOSE, W/CONNECTOR	
11	S08178000	2	ブランチUY-4	BRANCH, UY-4	
12	S04897000	2	プラグ4	PLUG, 4	
13	228475000	3	ケツソクバンド1.9X80	FASTENING BAND, 1.9X80	
21	021500106	2	1シユナツト5	NUT, 1 M5	
22	032422003	2	+2マルモク41X20	WOOD SCREW, ROUND 2 M4.1X20	
23	148847001	2	ザガネ	WASHER, PLAIN 4.76	
3-1	S53118001	1	ナイロンチューブ	AIR TUBE, RV-3A L=1600	
3-2	S53118002	1	ナイロンチューブ	AIR TUBE, RV-3B L=1600	
700	S51854209	1	デソソバルブ3Aクミ	VALVE ASSY, 3A	
700-1	S31551209	1	バルブトリツケイタ2-3	SETTING PLATE, 2-3 : VALVE	
700-2	S09318101	1	インテグレータ	INTEGRATOR	
700-3	S40628000	1	ボールバルブ1/4	BALL VALVE, 1/4	
700-4	S09228000	1	イケイニツプル	NIPPLE, 1/4X1/8	
700-5	S44748001	1	エアマニホルド3	AIR MANIFOLD, 3	
700-6	S43683001	3	デソソバルブ	SOLENOID VALVE	
700-7	S18415101	6	ハーフユニオンQ4M5	HALF UNION : Q4M5	
700-8	S43682100	1	バルブハーネスX2クミ	VALVE HARNESS ASSY, X2	
700-8-1	S12404000	2	クワタバルブコネクタ	VALVE CONNECTOR	
700-9	062302506	2	ナベコ3X25	SCREW, PAN M3X25	
700-10	028030242	2	ハネザガネ2-3	WASHER, SPRING 2-3	
700-11	025030232	2	ヒラザガネチユウ3	WASHER, PLAIN M 3	
700-12	S40629000	2	バレルニツプル	BARREL NIPPLE	
700-13	S23880000	2	エアマフラー	AIR MUFFLER	
700-14	S43686000	1	PTエルボ1/4	ELBOW, PT 1/4	
700-15	S43696100	1	バルブハーネスX1クミ	VALVE HARNESS ASSY, X1	
700-15-1	S44746100	1	ツイカバルブハーネス	VALVE HARNESS	
700-15-2	S44750100	1	ツイカバルブハーネス24V	VALVE HARNESS, 24V	
700-16	S40622000	1	EMIコアESD-SR-25	EMI CORE, ESD-SR-25	
700-17	149809000	1	タイラツプル	BEAD BAND, L=200	
700-18	S44287000	1	アースセン1050	GROUND WIRE, 1050	
700-19	0A5400806	1	+ナベザクミ4X8DB	SCREW, PAN (S/P WASHER) M4X8	

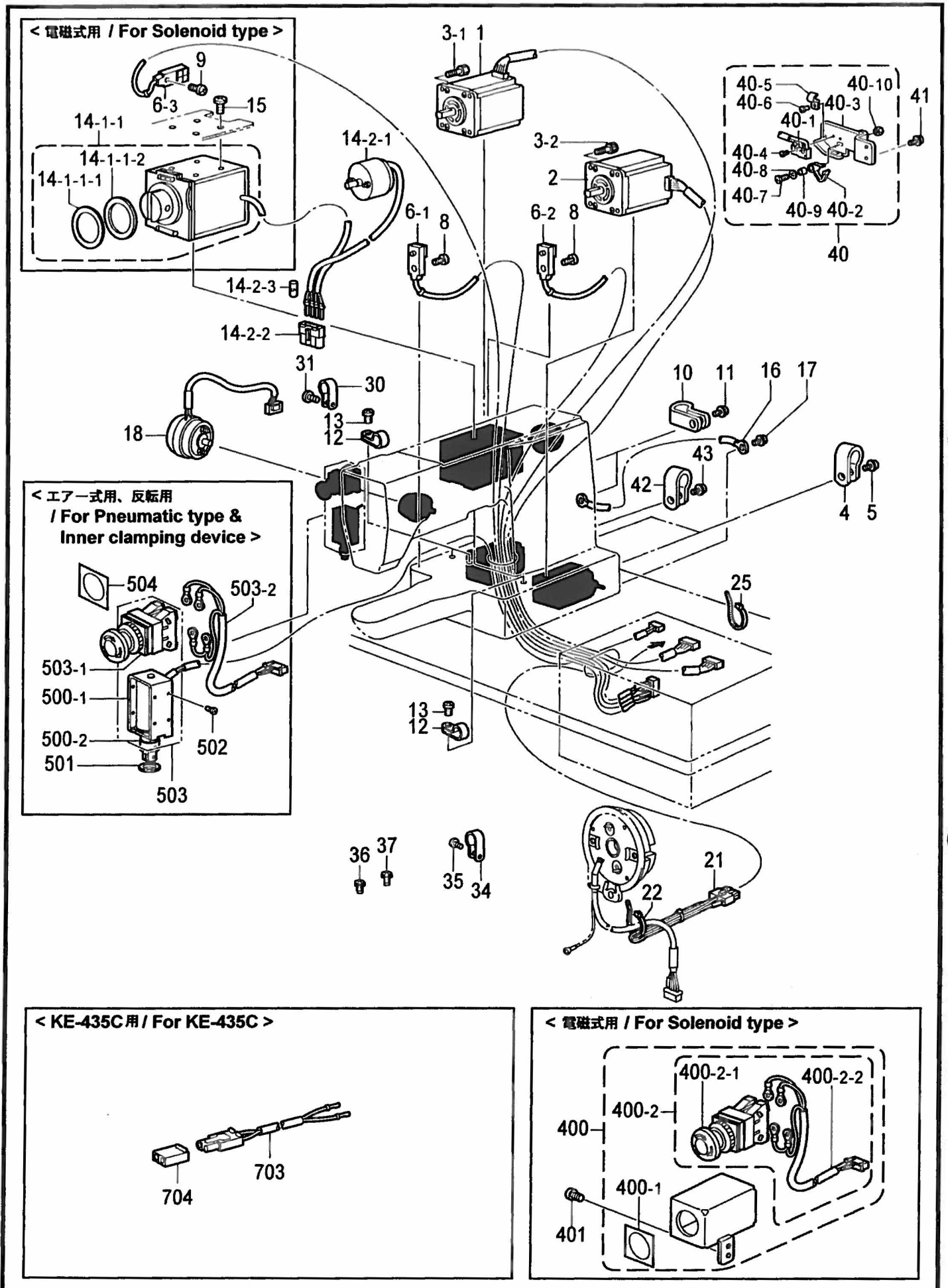

S. 電装品関係 / Power supply equipment mechanism

REF.NO	CODE	Q'TY	ヒンメイ	NAME OF PARTS	RM
			<KE-434C, KE-435C用>	<For KE-434C & KE-435C>	
1	S48587000	1	パルスモータXクミ	PULSE MOTOR ASSY, X	
2	S48589000	1	パルスモータYクミ	PULSE MOTOR ASSY, Y	
3-1	155055001	4	アナホルト4X45	BOLT, SOCKET M4X45	
3-2	018402532	4	アナホルト4X25	BOLT, SOCKET M4X25	
4	552907000	2	コードホルダ#10	CORD HOLDER, 10N	
5	0A5401006	2	ナベコハネヒラ4X10	SCREW, PAN (S/P WASHER) M4X10	
8	062300806	2	ナベコ3X8	SCREW, PAN M3X8	
10	552907000	2	コードホルダ#10	CORD HOLDER, 10N	
11	0A5401006	2	ナベコハネヒラ4X10	SCREW, PAN (S/P WASHER) M4X10	
12	625010000	3	ナイロンクランプNK-2N	NYLON CLAMP NK-2N	
13	062670512	3	ナベコ357-40X5	SCREW, PAN SM3.57-40X5	
16	S38148000	1	アースセン1	GROUND WIRE, 1	
17	0A5400806	1	ナベコサクミ4X8DB	SCREW, PAN (S/P WASHER) M4X8	
18	S49464000	1	イトリソレノイドクミ	THREAD TAKE-UP SOLENOID ASSY	
22	228475000	1	ケツソクバンド1.9X80	TYING BAND 1.9X80	
25	218859001	1	バインダM150	BINDER, M150	
34	S00480000	2	コードホルダ#5	CORD HOLDER, 5N	
35	060670612	2	バインド357-40X6	SCREW, BIND SM3.57-40X6	
36	060670612	1	バインド357-40X6	SCREW, BIND SM3.57-40X6	
37	060400616	1	バインドM4X6	SCREW, BIND M4X6	
40	S55629101	1	トウブスイッチクミ	HEAD SWITCH ASSY	
40-1	S55630001	1	マイクロスイッチクミ	MICRO SWITCH ASSY	
40-2	S38744101	1	スイッチイタハネ	SWITCH PLATE SPRING	
40-3	S55632001	1	スイッチダイ	SWITCH BRACKET	
40-4	062020806	2	ナベコ2X8	SCREW, PAN M2X8	
40-5	140647101	1	コードオサエ	CORD HOLDER	
40-6	062400616	1	ナベコM4X6	SCREW, PAN M4X6	
40-7	062401216	1	ナベコM4X12	SCREW, PAN M4X12	
40-8	026040236	1	ヒラサガネミガキ4	WASHER, PLAIN 4	
40-9	154514001	1	スペーサー	SPACER	
40-10	021400106	1	ナット1シユ4	NUT, 1 M4	
41	0A5401006	2	ナベコハネヒラ4X10	SCREW, PAN (S/P WASHER) M4X10	
42	552907000	1	コードホルダ#10	CORD HOLDER, 10N	
43	0A5401006	1	ナベコハネヒラ4X10	SCREW, PAN (S/P WASHER) M4X10	
			<KE-434C電磁式用>	<For Solenoid type of KE-434C>	
6	S49463100	1	トウブセンサクミ	HEAD SENSOR ASSY	
6-1	S56167000	1	キンセツセンサGL-N12F	PROXIMITY SENSOR, GL-12NF	
6-2	S56167001	1	キンセツセンサGL-N12F	PROXIMITY SENSOR, GL-12NF	
6-3	S56167003	1	キンセツセンサGL-N12F	PROXIMITY SENSOR, GL-12NF	
9	062300806	1	ナベコ3X8	SCREW, PAN M3X8	
14-1-1	S49979400	1	オサエソレノイドクミ	PRESSER SOLENOID ASSY	
14-1-1-1	S59366000	1	ダンバ1	SHOCK ABSORBER, 1	
14-1-1-2	S59367000	1	ダンバ2	SHOCK ABSORBER, 2	
14-2-1	S38144100	1	イトキソレノイドクミ	THREAD TRIMMER SOLENOID ASSY	
14-2-2	S38146000	1	コネクタ3191-04R	CONNECTOR :3191-04R	
14-2-3	S38147000	1	マークチューブ5	MARK TUBE, 5	
15	060501016	4	バインドM5X10	SCREW, BIND M5X10	
			<中厚物用>	<For Medium-weight materials>	
21	S49465006	1	ショウキリカエコネクタクミ	CONNECTOR ASSY	
			<厚物用>	<For Heavy-weight materials>	
21	S49465007	1	ショウキリカエコネクタクミ	CONNECTOR ASSY	
30	525664000	3	コードホルダ#6	CORD HOLDER, 6N	
31	060670612	3	バインド357-40X6	SCREW, BIND SM3.57-40X6	

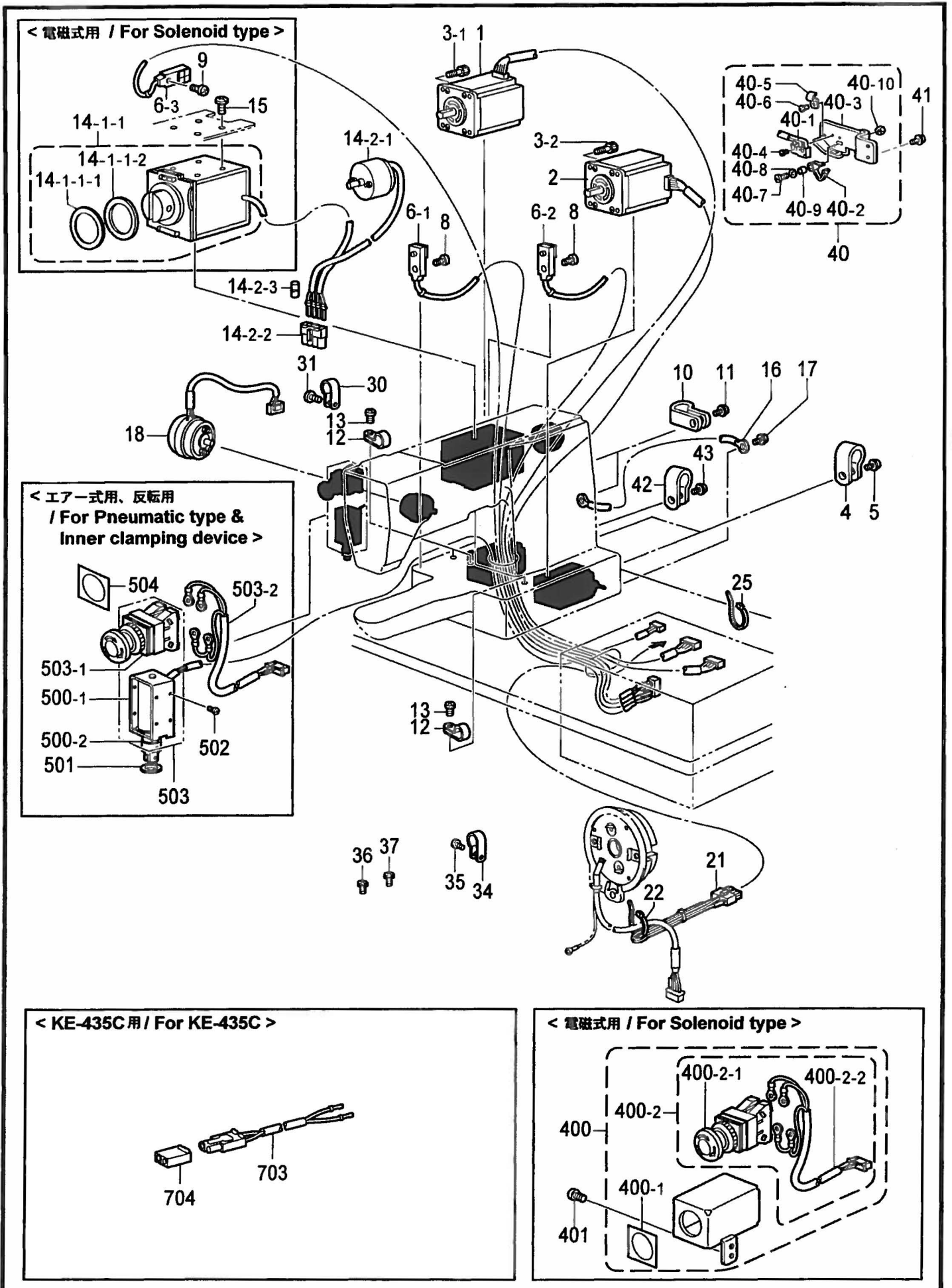

S . 電装品関係 / Power supply equipment mechanism

REF.NO	CODE	Q'TY	ヒンメイ	NAME OF PARTS	RM
400	S49934009	1	<KE-434C電磁式用> EMロックSWクミ	<For Solenoid type of KE-434C> EM-LOCK SWITCH ASSY	
400-1	S37057001	1	EMスイッチスペーサ3	EM-SWITCH SPACER, 3	
400-2	S49482000	1	EMロックSWハーネスクミ	EM-LOCK SWITCH & HARNESS ASSY	
400-2-1	S32335100	1	SW-AVS311N	SWITCH :AVS311N	
400-2-2	S49466000	1	EMSWハーネス	EM-SWITCH HARNESS	
401	062710812	2	ナベコ476-32X8	SCREW, PAN SM4.76-32X8	
			<KE-434Cエア一式用、 反転用>	<For Pneumatic type & Inner clamping device of KE-434C>	
6	S53136100	1	トウブセンサエアクミ	HEAD SENSOR AIR ASSY	
6-1	S56167000	1	キンセツセンサGL-N12F	PROXIMITY SENSOR, GL-12NF	
6-2	S56167001	1	キンセツセンサGL-N12F	PROXIMITY SENSOR, GL-12NF	
14-2-1	S38144100	1	イトキリソレノイドクミ	THREAD TRIMMER SOLENOID ASSY	
14-2-2	S38146000	1	コネクタ3191-04R	CONNECTOR :3191-04R	
14-2-3	S38147000	1	マークチューブ5	MARK TUBE, 5	
			<KE-434Cエア一式用>	<For Pneumatic type of KE-434C>	
21	S49465010	1	シヨウキリカエコネクタクミ	CONNECTOR ASSY	
			<KE-434C反転用>	<Inner clamping device of KE-434C>	
21	S49465011	1	シヨウキリカエコネクタクミ	CONNECTOR ASSY	
30	525664000	6	コードホルダ#6	CORD HOLDER, 6N	
31	0A5400806	6	ナベサクミ4X8DB	SCREW, PAN (S/P WASHER) M4X8	
500-1	S41203051	1	イトハラソレノイド	THREAD WIPER SOLENOID	
500-2	S41204050	1	プランジヤコム	PLUNGER RUBBER	
501	115007001	1	サカネ	WASHER,PLAIN 13	
502	062300612	4	ナベコ3X6	SCREW, PAN M3X6	
503	S49482000	1	EMロックSWハーネスクミ	EM-LOCK SWITCH & HARNESS ASSY	
503-1	S32335100	1	SW-AVS311N	SWITCH :AVS311N	
503-2	S49466000	1	EMSWハーネス	EM-SWITCH HARNESS	
504	S37057001	1	EMスイッチスペーサ3	EM-SWITCH SPACER, 3	
			<KE-435C用>	<For KE-435C>	
6	S53136100	1	トウブセンサエアクミ	HEAD SENSOR AIR ASSY	
6-1	S56167000	1	キンセツセンサGL-N12F	PROXIMITY SENSOR, GL-12NF	
6-2	S56167001	1	キンセツセンサGL-N12F	PROXIMITY SENSOR, GL-12NF	
14-2-1	S38144100	1	イトキリソレノイドクミ	THREAD TRIMMER SOLENOID ASSY	
14-2-2	S38146000	1	コネクタ3191-04R	CONNECTOR :3191-04R	
14-2-3	S38147000	1	マークチューブ5	MARK TUBE, 5	
21	S49465012	1	シヨウキリカエコネクタクミ	CONNECTOR ASSY	
30	525664000	6	コードホルダ#6	CORD HOLDER, 6N	
31	0A5400806	6	ナベサクミ4X8DB	SCREW, PAN (S/P WASHER) M4X8	
703	S55432000	1	ワイパーチュークエイハーネス	RELAY HARNESS, WIPER	
704	S55433000	1	コネクタ3191-02P1	CONNECTOR:3191-02P1	

T. 操作パネル関係 / Operation panel mechanism

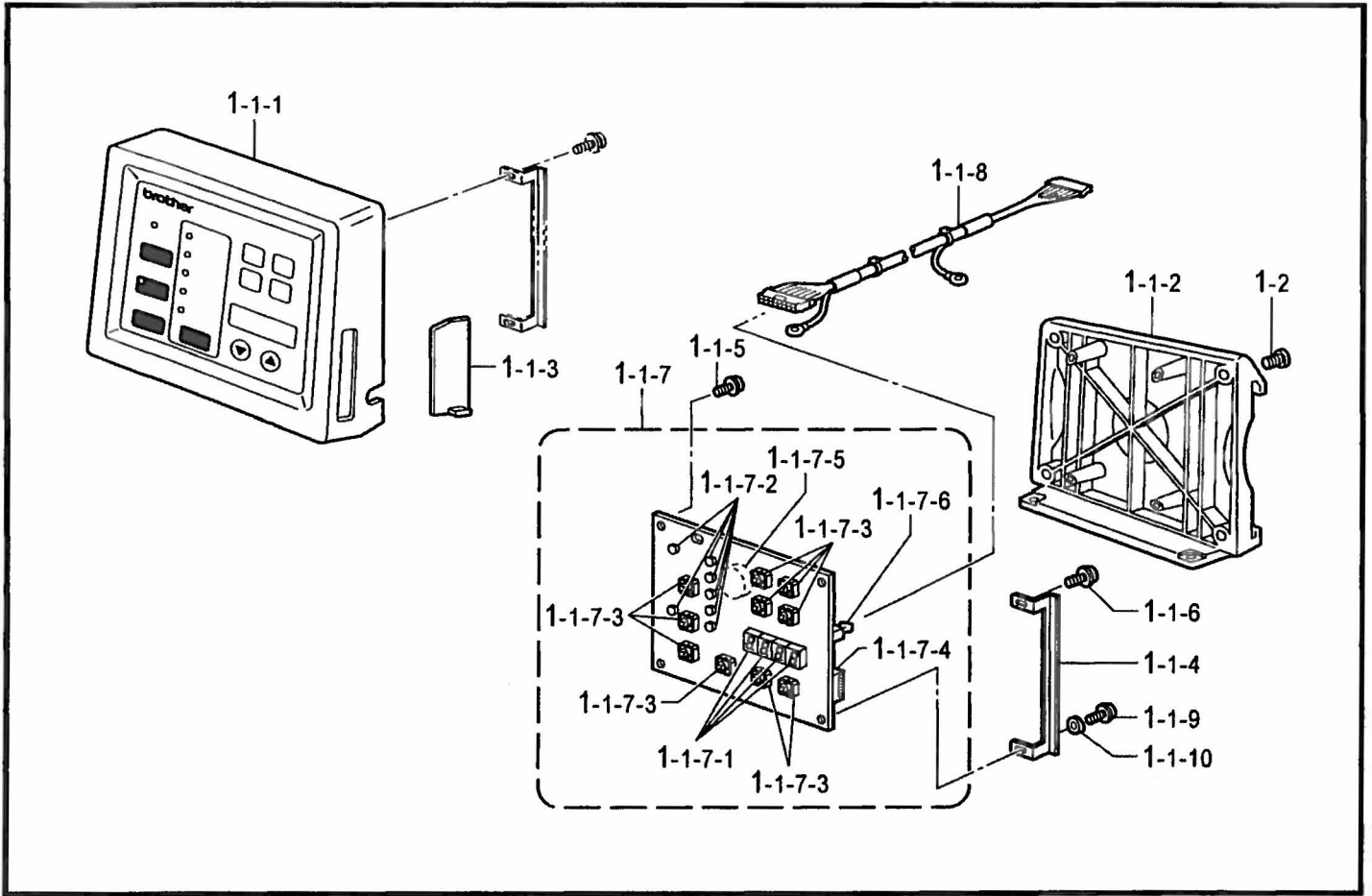

KE-434C/435C-530

U. 動力台関係 / Power table

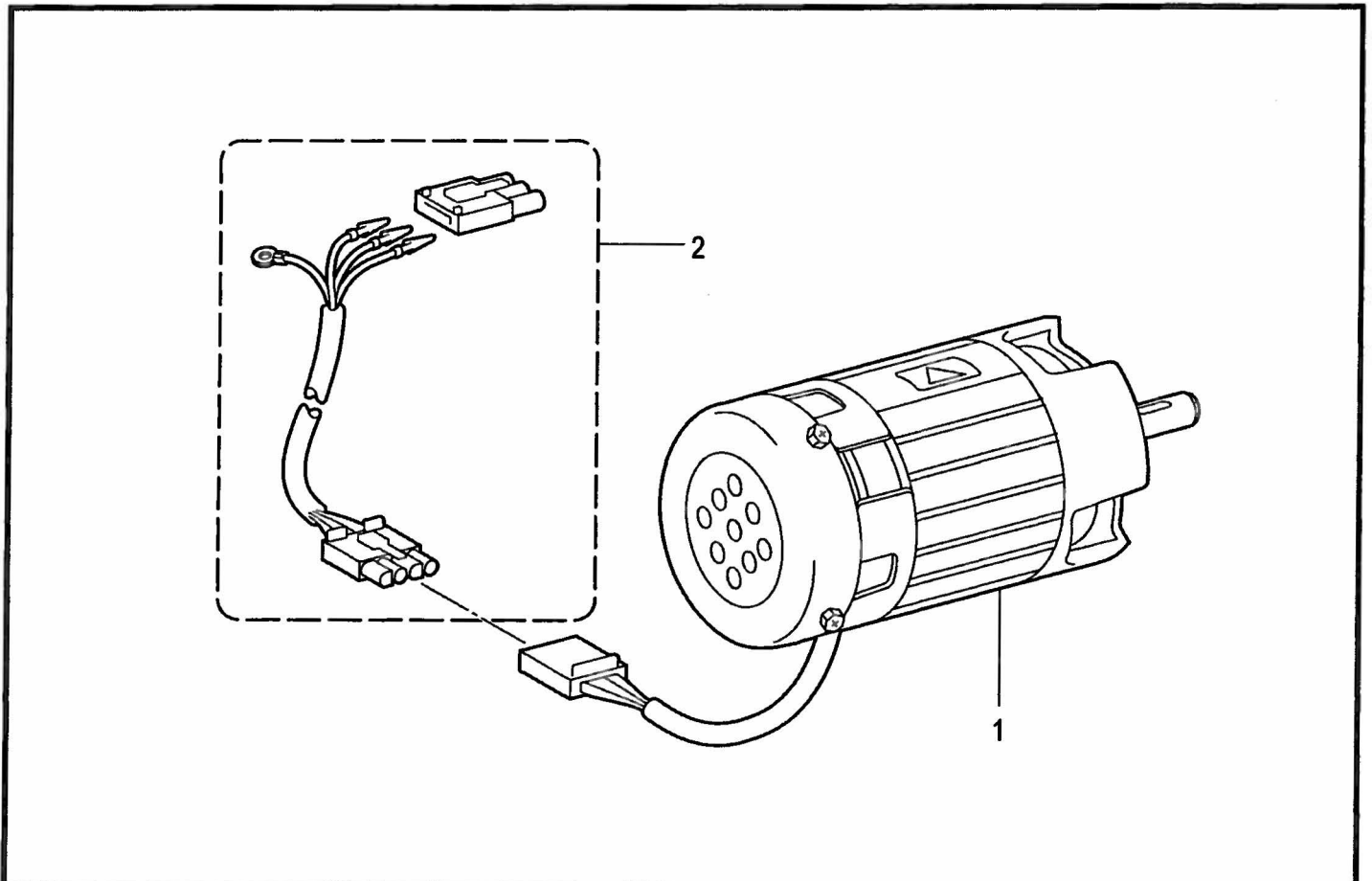

KE-434C/435C-652

T. 操作パネル関係 / Operation panel mechanism

REF.NO	CODE	Q'TY	ヒンメイ	NAME OF PARTS	RM
1	S55889001	1	ソウサパネルソウキ	OPERATION PANEL UNIT	
1-1	S55890001	1	ソウサパネルIMキ	OPERATION PANEL ASSY, IM	
1-1-1	S55891000	1	マエフレームIMキ	FRONT FRAME ASSY, IM	
1-1-2	S52091000	1	ウシロフレームキ	REAR FRAME ASSY	
1-1-3	S49495000	1	パネルヨコカバー	PANEL SIDE COVER	
1-1-4	S49496001	1	パネルヨコカバーガイド	PANEL SIDE COVER GUIDE	
1-1-5	087310815	2	カップBタイ3X8	TAPTITE, CUP B M3X8	
1-1-6	0A4400805	1	ナベサキキ4X8DA	SCREW, PAN (S/P WASHER) M4X8	
1-1-7-1	S49497001	1	パネルキバンキ	PANEL PCB ASSY	
1-1-7-2	S29023000	4	LEDGL9P040	LED :GL9P040	
1-1-7-3	S46703000	7	LEDPG5307S	LED :PG5307S	
1-1-7-4	S48579000	10	SWB3F-4050	SWITCH :B3F-4050	
1-1-7-5	U34870001	1	DIPSW KSP08	DIP SWITCH:KSP08	
1-1-7-6	S30280000	1	ブザーPKB24SPC3	BUZZER :PKB24SPC36	
1-1-7-7	UL0025000	1	コネクタ3429-6002S	CONNECTOR:3429-6002SC	
1-1-8	S49510000	1	パネルケーブルキ	PANEL HARNESS ASSY	
1-1-9	087311015	2	カップBタイ3X10	TAPTITE, CUP B M3X10	
1-1-10	XA2220050	2	キバンオサエ	PCB HOLDER	
1-2	062300806	4	ナベコ3X8	SCREW, PAN M3X8	

KE-434C/435C-530

U. 動力台関係 / Power table

REF.NO	CODE	Q'TY	ヒンメイ	NAME OF PARTS	RM
1	J80868001	1	CIMモータ430キホ	CIM MOTOR ASSY, 430	
2	S53055100	1	IMハーネスキ	HARNESS ASSY, IM	

KE-434C/435C-652

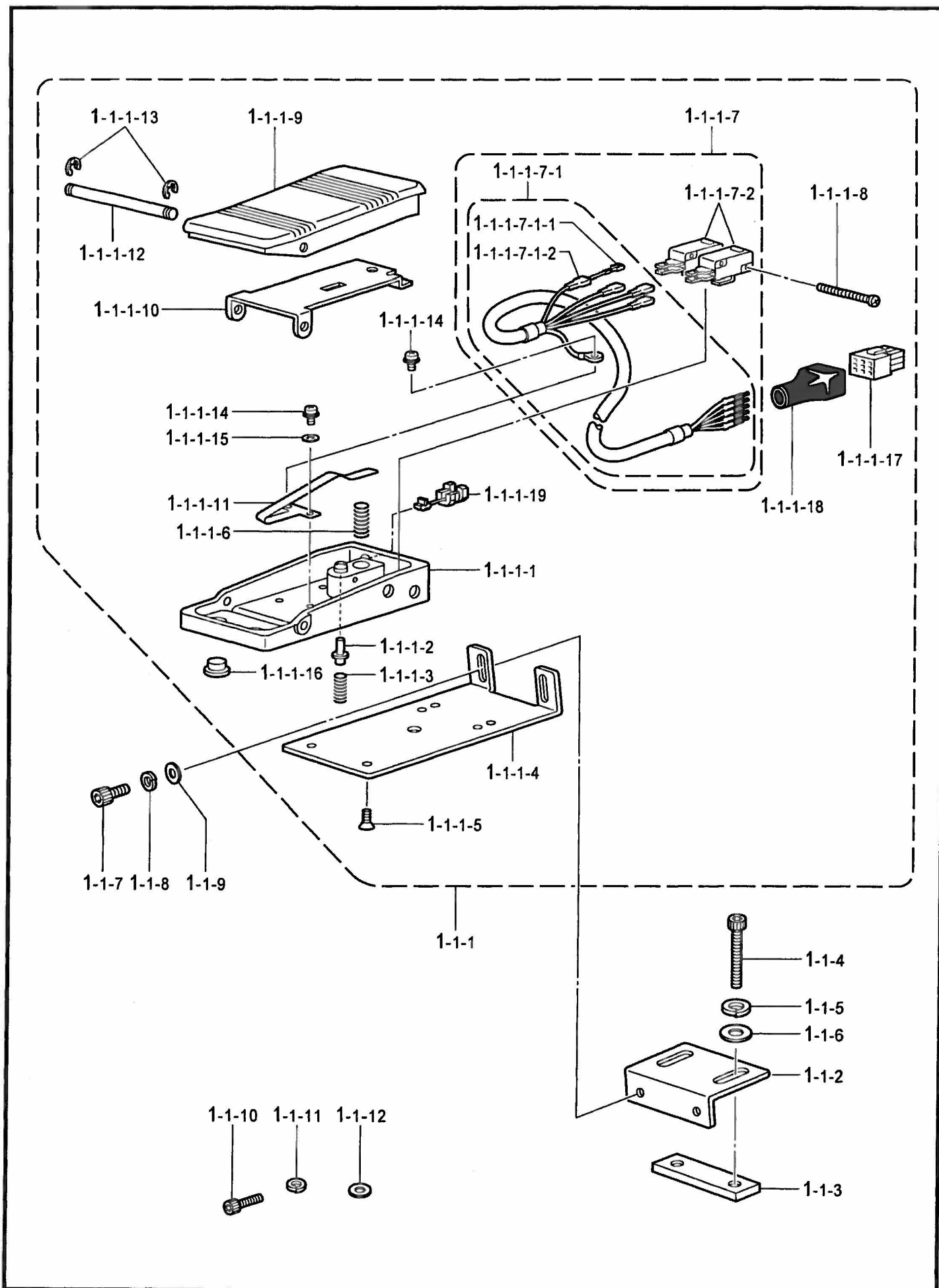

V1 . 踏板関係 (KE-434C電磁式用) / Foot switch pedal mechanism (For Solenoid type of KE-434C)

REF.NO	CODE	Q'TY	ヒンメイ	NAME OF PARTS	RM
1-1	S49667101	1	2ダンフツSWセット	2-STEP FOOT SWITCH SET	
1-1-1	S49668101	1	2ダンフツSWクミ	2-STEP FOOT SWITCH ASSY	
1-1-1-1	S49669100	1	フツペダルタイクミ	FOOT PEDAL BASE ASSY	
1-1-1-2	S49672001	1	2ダンSWピン	2-STEP SWITCH PIN	
1-1-1-3	S38168001	1	アツシユクハネ	SPRING, COMPRESSION 10X30	
1-1-1-4	S38169201	1	フツSWジジイタB	FOOT SWITCH SUPPORT PLATE, B	
1-1-1-5	004400603	2	+サヲコネジ4X6	SCREW, FLAT M4X6	
1-1-1-6	S38170001	1	フツペダルハネ	FOOT PEDAL SPRING	
1-1-1-7	S54648000	1	フツSWハーネスクミ	FOOT SWITCH HARNESS ASSY	
1-1-1-7-1	S54646000	1	フツSWハーネス	FOOT SWITCH HARNESS	
1-1-1-7-1-1	S54644000	2	サシヨミタンシメス	TERMINAL, FEMALE	
1-1-1-7-1-2	S54645000	2	セツエンカバー	INSULATION COVER	
1-1-1-7-2	S36260000	2	スイツチVXヒンボタン	MICRO SWITCH, VX :PIN BUTTON	
1-1-1-8	062302506	2	ナヘコ3X25	SCREW, PAN M3X25	
1-1-1-9	S51451000	1	フツペダル	FOOT PEDAL	
1-1-1-10	S49673000	1	ペダルホゴイタ	PEDAL PROTECTION PLATE	
1-1-1-11	S49674001	1	スイツチオサエハネ	SWITCH PRESSER SPRING	
1-1-1-12	S38177001	1	フツペダルジク	FOOT PEDAL SHAFT	
1-1-1-13	048050346	2	トメワE5	RETAINING RING, E5	
1-1-1-14	052400606	2	ナヘコハネヒラ4X6	SCREW, PAN (S/P WASHER) M4X6	
1-1-1-15	025040236	1	ヒラサカネチユウ4	WASHER, PLAIN M 4	
1-1-1-16	117936001	4	ゴムセン9.4	RUBBER CAP, 9.4	
1-1-1-17	S38180000	1	コネクタ172169-1	CONNECTOR :172169-1	
1-1-1-18	S36682000	1	コネクタキャップ	CONNECTOR CAP	
1-1-1-19	S46694000	1	コードフツシユKR61A	CORD BUSH :KR61A	
1-1-2	S38178101	1	フツSWジジイタA	FOOT SWITCH SUPPORT PLATE, A	
1-1-3	S38179101	1	フツSWジジイタC	FOOT SWITCH SUPPORT PLATE, C	
1-1-4	018082536	2	アナホルト8X25	BOLT, SOCKET M8X25	
1-1-5	028080246	2	ハネサカネ2-8	WASHER, SPRING 2-8	
1-1-6	025080236	2	ヒラサカネチユウ8	WASHER, PLAIN M 8	
1-1-7	018501036	2	アナホルト5X10	BOLT, SOCKET M5X10	
1-1-8	028050246	2	ハネサカネ2-5	WASHER, SPRING 2-5	
1-1-9	025050236	2	ヒラサカネチユウ5	WASHER, PLAIN M 5	
1-1-10	018401236	2	アナホルト4X12	BOLT, SOCKET M4X12	
1-1-11	028040246	2	ハネサカネ2-4	WASHER, SPRING 2-4	
1-1-12	025040236	2	ヒラサカネチユウ4	WASHER, PLAIN M 4	

V2. 踏板関係 (KE-434C 電磁式用オプション部品) /

Foot switch pedal mechanism (Option parts for Solenoid type of KE-434C)

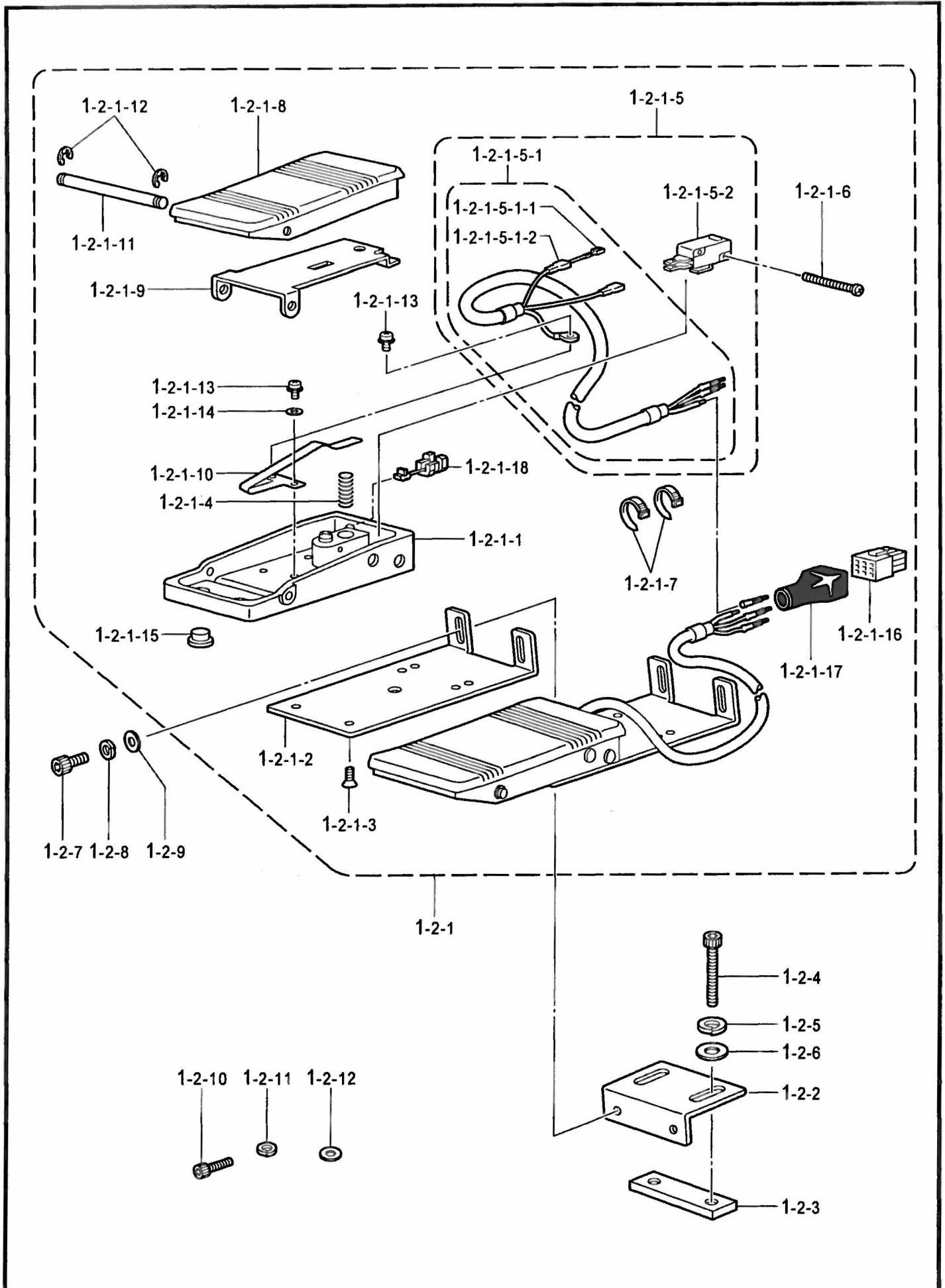

KE-434C/435C-651

V2 . 踏板関係 (KE-434C電磁式用オプション部品) /

Foot switch pedal mechanism (Option parts for Solenoid type of KE-434C)

REF.NO	CODE	Q'TY	ヒンメイ	NAME OF PARTS	RM
1-2	S49675101	1	2レンペダルセット	2-PEDAL FOOT SWITCH SET	
1-2-1	S49676101	1	2レンペダルクミ	2-PEDAL FOOT SWITCH ASSY	
1-2-1-1	S49669100	2	フットペダルタイクミ	FOOT PEDAL BASE ASSY	
1-2-1-2	S38169201	2	フットSWシジイタB	FOOT SWITCH SUPPORT PLATE, B	
1-2-1-3	004400603	4	+サラコネジ4X6	SCREW, FLAT M4X6	
1-2-1-4	S38170001	2	フットペダルハネ	FOOT PEDAL SPRING	
1-2-1-5	S54649000	1	2レンフットSWハーネスクミ	2-PEDAL FOOT SW HARNESS ASSY	
1-2-1-5-1	S54647000	2	2レンフットSWハーネス	2-PEDAL FOOT SWITCH HARNESS	
1-2-1-5-1-1	S54644000	4	サシコミタンシメス	TERMINAL, FEMALE	
1-2-1-5-1-2	S54645000	4	ゼツエンカバー	INSULATION COVER	
1-2-1-5-2	S36260000	2	スイッチVXピンボタン	MICRO SWITCH, VX :PIN BUTTON	
1-2-1-6	062301205	4	ナベコ3X12	SCREW, PAN M3X12	
1-2-1-7	228475000	8	ケツソクバンド1.9X80	TYING BAND 1.9X80	
1-2-1-8	S51451000	2	フットペダル	FOOT PEDAL	
1-2-1-9	S49673000	2	ペダルホコイタ	PEDAL PROTECTION PLATE	
1-2-1-10	S49674001	2	スイッチオサエハネ	SWITCH PRESSER SPRING	
1-2-1-11	S38177001	2	フットペダルシク	FOOT PEDAL SHAFT	
1-2-1-12	048050346	4	トメワE5	RETAINING RING, E5	
1-2-1-13	052400606	4	ナベコハネヒラ4X6	SCREW, PAN (S/P WASHER) M4X6	
1-2-1-14	025040236	2	ヒラサカネチユウ4	WASHER, PLAIN M 4	
1-2-1-15	117936001	8	ゴムセン9.4	RUBBER CAP, 9.4	
1-2-1-16	S38180000	1	コネクタ172169-1	CONNECTOR :172169-1	
1-2-1-17	S38060000	1	コネクタキャップ18X19	CONNECTOR CAP, 18X19	
1-2-1-18	S46694000	2	コードブッシュKR61A	CORD BUSH :KR61A	
1-2-2	S38178101	2	フットSWシジイタA	FOOT SWITCH SUPPORT PLATE, A	
1-2-3	S38179101	2	フットSWシジイタC	FOOT SWITCH SUPPORT PLATE, C	
1-2-4	018082536	4	アナホルト8X25	BOLT, SOCKET M8X25	
1-2-5	028080246	4	ハネサカネ2-8	WASHER, SPRING 2-8	
1-2-6	025080236	4	ヒラサカネチユウ8	WASHER, PLAIN M 8	
1-2-7	018501036	4	アナホルト5X10	BOLT, SOCKET M5X10	
1-2-8	028050246	4	ハネサカネ2-5	WASHER, SPRING 2-5	
1-2-9	025050236	4	ヒラサカネチユウ5	WASHER, PLAIN M 5	
1-2-10	018401236	4	アナホルト4X12	BOLT, SOCKET M4X12	
1-2-11	028040246	4	ハネサカネ2-4	WASHER, SPRING 2-4	
1-2-12	025040236	4	ヒラサカネチユウ4	WASHER, PLAIN M 4	

V3 . 踏板関係 (エア一式用) / Foot switch pedal mechanism (For Pneumatic type)

< KE-434C 反転用 / For Inner clamping device of KE-434C >
 < KE-434C エア一式用 / For Pneumatic type of KE-434C >
 < KE-435C 用 / For KE-435C >

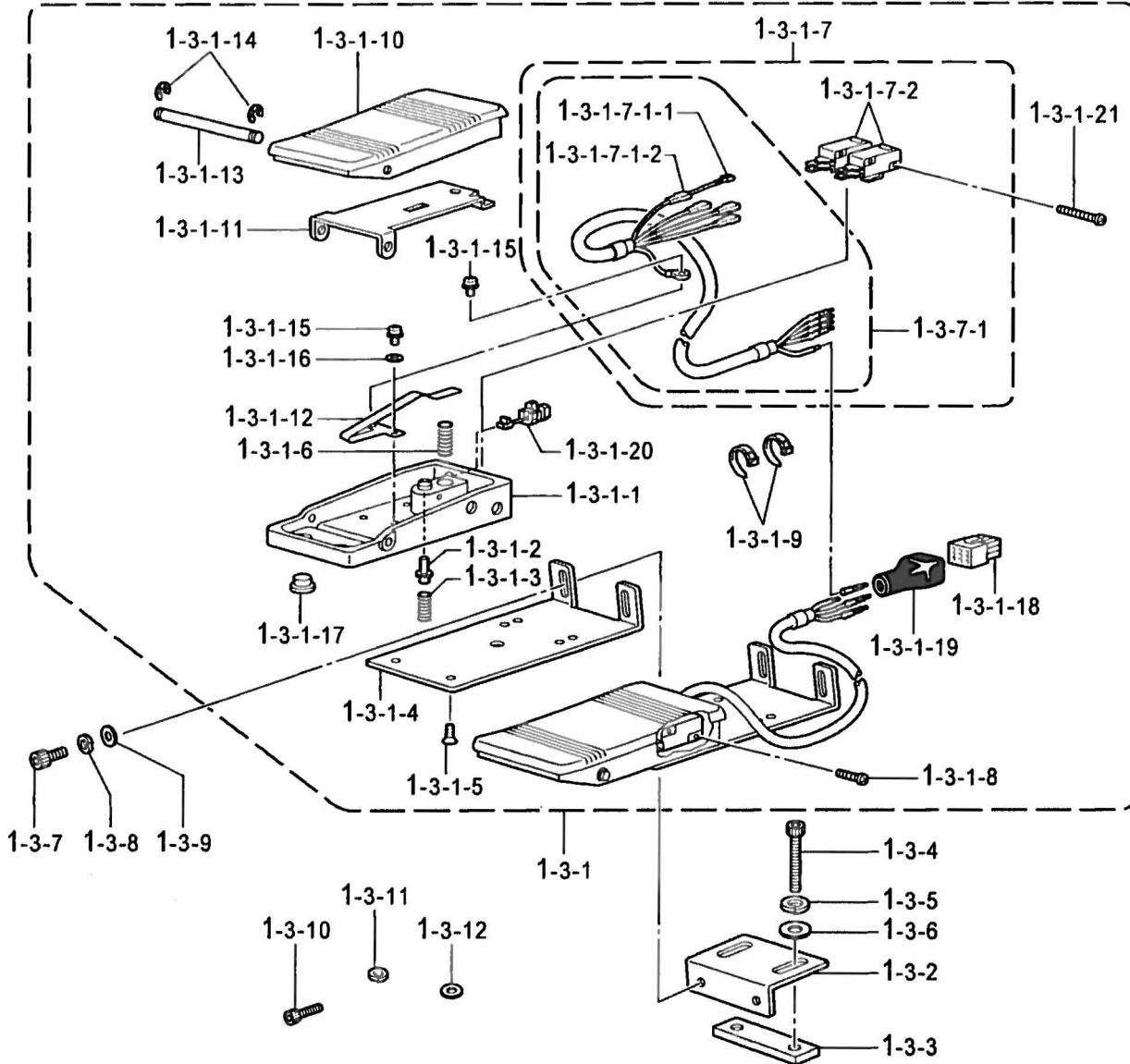

" オプション部品 / OPTION PARTS "

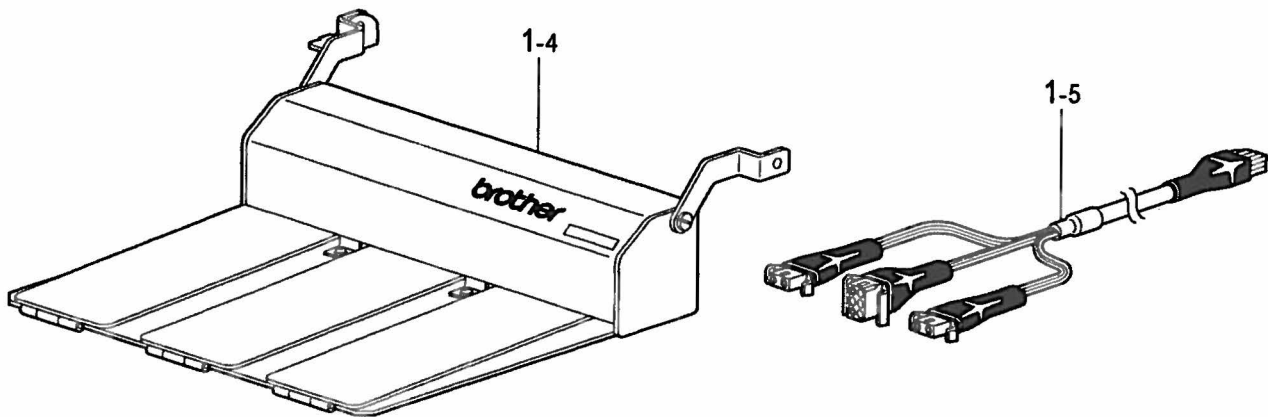

V3 . 踏板関係 (エア一式用) / Foot switch pedal mechanism (For pneumatic type)

REF.NO	CODE	Q'TY	ヒンメイ	NAME OF PARTS	RM
			<KE-434Cエア一式用> <KE-434C反転用> <KE-435C用>	<For pneumatic type of KE-434C> <For Inner clamping device of KE-434C> <For KE-435C>	
1-3	S51846101	1	2レソフツ3SWセツ	2-PEDAL FOOT SWITCH SET, 3	
1-3-1	S51847101	1	2レソフツ3SWクミ	2-PEDAL FOOT SWITCH ASSY, 3	
1-3-1-1	S49669100	2	フツヘダルダイクミ	FOOT PEDAL BASE ASSY	
1-3-1-2	S49672001	1	2ダンSWピン	2-STEP SWITCH PIN	
1-3-1-3	S38168001	1	アツシユクハネ	SPRING, COMPRESSION 10X30	
1-3-1-4	S38169201	2	フツSWシヅイタB	FOOT SWITCH SUPPORT PLATE, B	
1-3-1-5	004400603	4	+サラコネジ4X6	SCREW, FLAT M4X6	
1-3-1-6	S38170001	2	フツヘダルハネ	FOOT PEDAL SPRING	
1-3-1-7	S54650000	1	2レソフツ3SWハーネスクミ	2-PEDAL F-SWITCH HARNESS ASSY	
1-3-1-7-1	S54691000	1	2レソフツ3SWハーネス	2-PEDAL FOOT SWITCH HARNESS	
1-3-1-7-1-1	S54644000	6	サンコミタンシメス	TERMINAL, FEMALE	
1-3-1-7-1-2	S54645000	6	ゼツエンカバー	INSULATION COVER	
1-3-1-7-2	S36260000	3	スイツチVXピンボタン	MICRO SWITCH, VX:PIN BUTTON	
1-3-1-8	062301205	2	ナヘコ3X12	SCREW, PAN M3X12	
1-3-1-9	228475000	8	ケツソクバンド1.9X80	TYING BAND 1.9X80	
1-3-1-10	S51451000	2	フツヘダル	FOOT PEDAL	
1-3-1-11	S49673000	2	ヘダルホコイタ	PEDAL PROTECTION PLATE	
1-3-1-12	S49674001	2	スイツチオサエハネ	SWITCH PRESSER SPRING	
1-3-1-13	S38177001	2	フツヘダルシク	FOOT PEDAL SHAFT	
1-3-1-14	048050346	4	トメワE5	RETAINING RING, E5	
1-3-1-15	052400606	4	ナヘコハネヒラ4X6	SCREW, PAN (S/P WASHER) M4X6	
1-3-1-16	025040236	2	ヒラザガネチユウ4	WASHER, PLAIN M 4	
1-3-1-17	117936001	8	ゴムセン9.4	RUBBER CAP, 9.4	
1-3-1-18	S38180000	1	コネクタ172169-1	CONNECTOR :172169-1	
1-3-1-19	S38060000	1	コネクタキヤツブ18X19	CONNECTOR CAP, 18X19	
1-3-1-20	S46694000	2	コートフツシユKR61A	CORD BUSH :KR61A	
1-3-1-21	062302506	2	ナヘコ3X25	SCREW, PAN M3X25	
1-3-2	S38178101	2	フツSWシヅイタA	FOOT SWITCH SUPPORT PLATE, A	
1-3-3	S38179101	2	フツSWシヅイタC	FOOT SWITCH SUPPORT PLATE, C	
1-3-4	018082536	4	アナホルト8X25	BOLT, SOCKET M8X25	
1-3-5	028080246	4	ハネザガネ2-8	WASHER, SPRING 2-8	
1-3-6	025080236	4	ヒラザガネチユウ8	WASHER, PLAIN M 8	
1-3-7	018501036	4	アナホルト5X10	BOLT, SOCKET M5X10	
1-3-8	028050246	4	ハネザガネ2-5	WASHER, SPRING 2-5	
1-3-9	025050236	4	ヒラザガネチユウ5	WASHER, PLAIN M 5	
1-3-10	018401236	4	アナホルト4X12	BOLT, SOCKET M4X12	
1-3-11	028040246	4	ハネザガネ2-4	WASHER, SPRING 2-4	
1-3-12	025040236	4	ヒラザガネチユウ4	WASHER, PLAIN M 4	
			" オプション部品 "	" OPTION PARTS "	
1-4	291662003	1	タチヘダル 2ソクシロ	STANDING OPE. PEDAL, 2 SPEED	
1-5	S29017000	1	フツSWヘンソクコト	FOOT CONVERSION HARNESS	

V4 . 踏板関係 (オプション部品) / Foot switch pedal mechanism (Option parts)

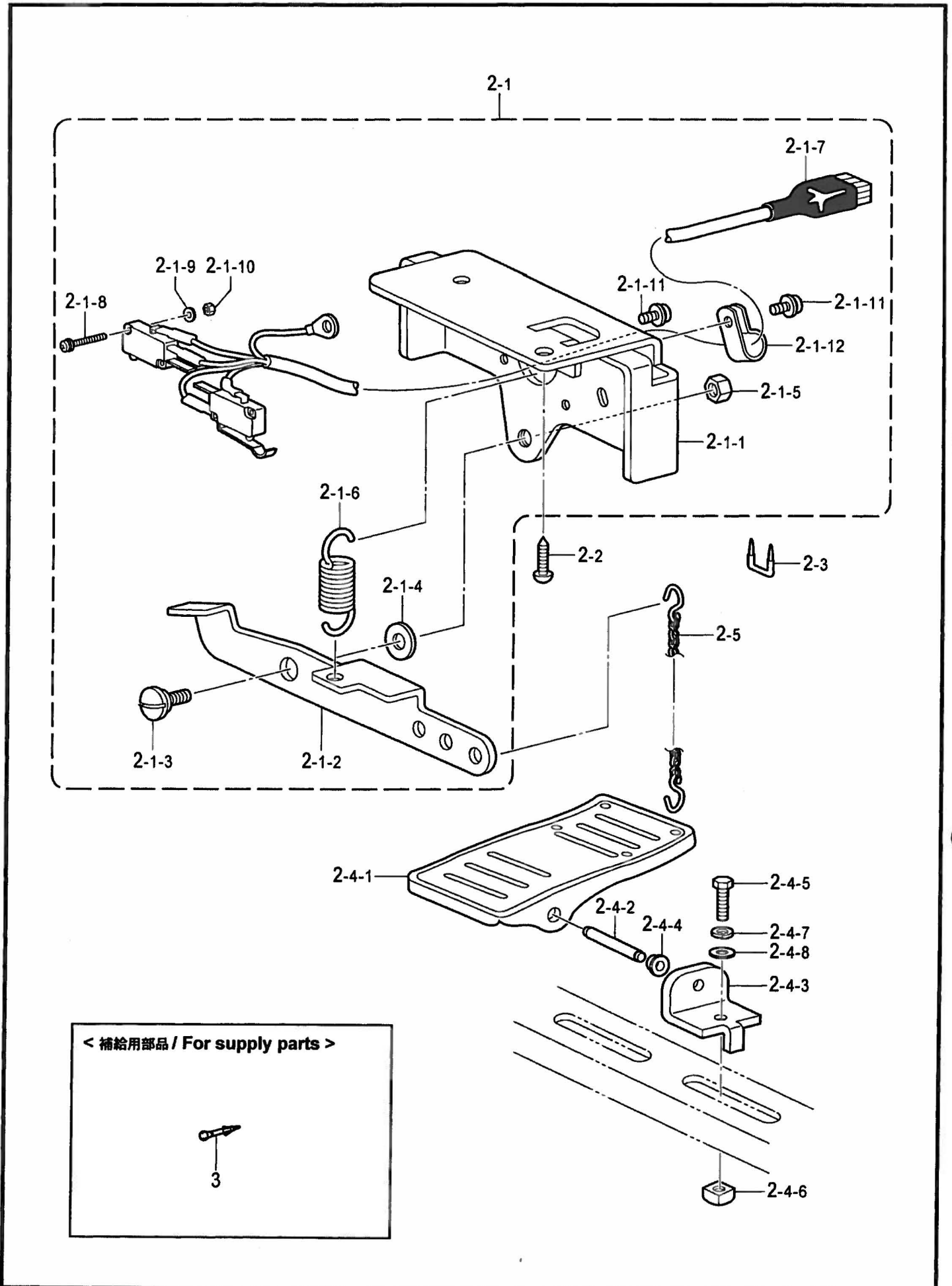

KE-434C/435C-651

V4 . 踏板関係 (オプション部品) / Foot switch pedal mechanism (Option parts)

REF.NO	CODE	Q'TY	ヒンメイ	NAME OF PARTS	RM
			“ オプション部品 ”	“ OPTION PARTS ”	
2	S46131001	1	2ダンフツSWセットOP	2-STEP FOOT SWITCH SET, OP	
2-1	S46132001	1	2ダンフツSWクミOP	2-STEP FOOT SWITCH ASSY, OP	
2-1-1	S46133001	1	SWサエダイ	SWITCH BRACKET	
2-1-2	S46134001	1	フツSWレバー	FOOT SWITCH LEVER	
2-1-3	148904001	1	ダンネジ7.94	SHOULDER SCREW, SM7.94	
2-1-4	025080236	1	ヒラサガネチユウ8	WASHER, PLAIN M 8	
2-1-5	101268002	1	ナツ7.94	NUT, SM7.94	
2-1-6	S46135001	1	フツSWハネ	FOOT SWITCH SPRING	
2-1-7	S46136000	1	フツSWハーネスクミOP	FOOT SWITCH HARNESS ASSY, OP	
2-1-8	UD2390001	4	+ナベセムス3X20DA	SCREW, PAN (S/P WASHER) M3X20	
2-1-9	025030236	2	ヒラサガネチユウ3	WASHER, PLAIN M 3	
2-1-10	021300206	2	2シユナツ3	NUT, 2 M3	
2-1-11	052400806	2	ナベコハネヒラ4X8	SCREW, PAN (S/P WASHER) M4X8	
2-1-12	S00480000	1	コートホルダ#5	CORD HOLDER, 5N	
2-2	100666002	2	マルモクネジ5.5X20	WOOD SCREW, ROUND M5.5X20	
2-3	200190001	3	ステツフル	STAPLE	
2-4	S01603009	1	オサエアケフミイタクミ	TREADLE ASSY	
2-4-1	S01199003	1	オサエアケフミイタ	TREADLE PEDAL	
2-4-2	133188001	1	オサエアケフミイタジク	TREADLE SHAFT	
2-4-3	119707003	2	フミイタジクウケ	TREADLE SHAFT BRACKET	
2-4-4	119708001	2	フミイタジクウケカー	TREADLE BUSHING COLLAR	
2-4-5	017082206	2	ホルト8X22	BOLT, M8X22	
2-4-6	116694001	2	4カクナツ8	NUT, SQUARE M8	
2-4-7	028080240	2	ハネサガネ2-8	WASHER, SPRING 2-8	
2-4-8	025080236	2	ヒラサガネチユウ8	WASHER, PLAIN M 8	
2-5	142656001	1	クサリクミ	CHAIN ASSY	
			< 補給用部品 >	< For Supply parts >	
3	S49443000	1	コンタクト170364-1	CONTACT :170364-1	

W1 . 付属装置関係 (オプション部品) / Attachment set (Option parts)

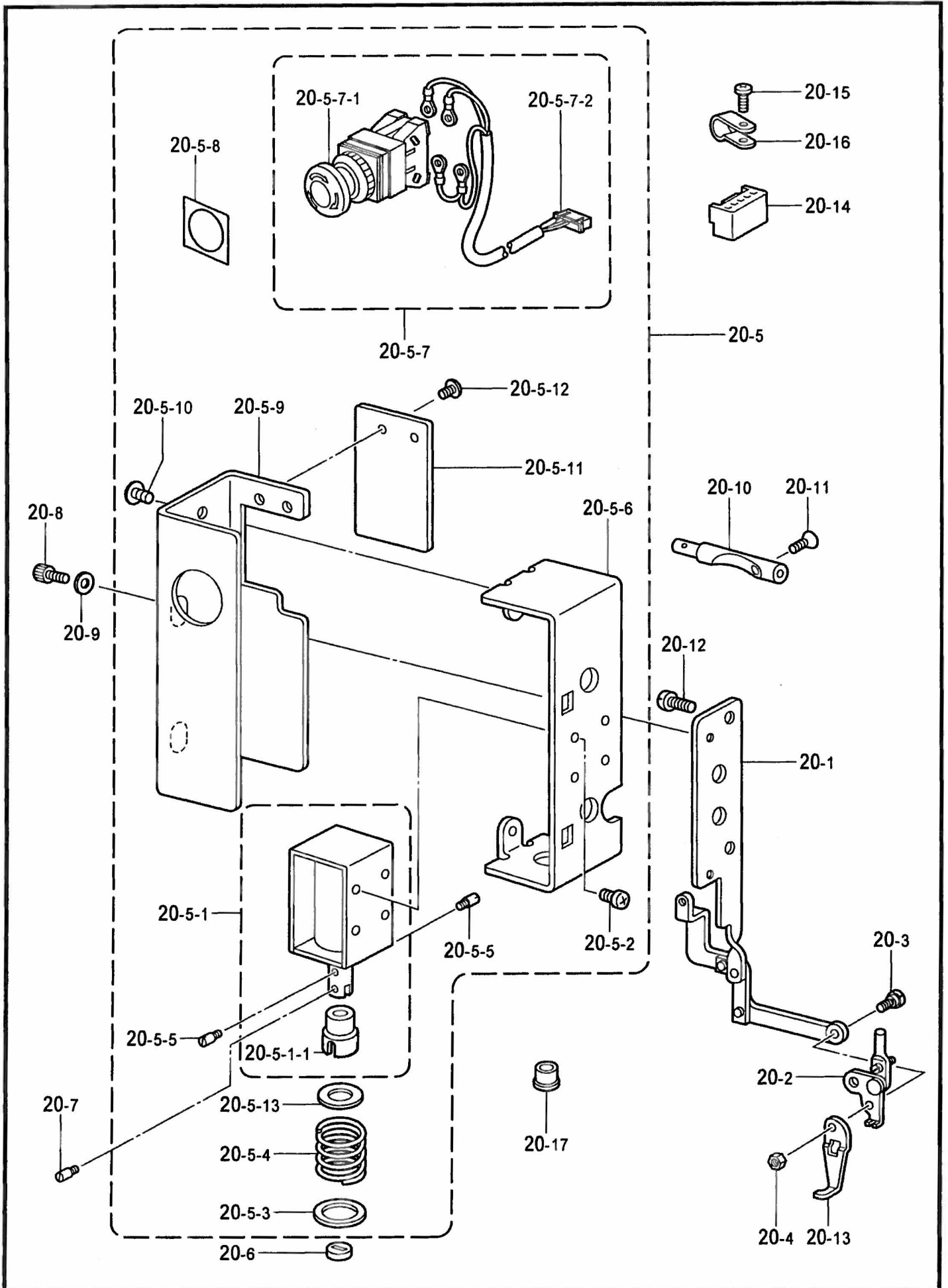

KE-434C/435C-940

W1 . 付属装置関係 (オプション部品) / Attachment set (Option parts)

REF.NO	CODE	Q'TY	ヒンメイ	NAME OF PARTS	RM
			" オプション部品 "	" OPTION PARTS "	
20	S49615009	1	ソレノイドワイパー	SOL. TYPE THREAD WIPER ASSY	
20-1	S41656001	1	イトハラレンカン	TR-WIPER CONNECTING ROD ASSY	
20-2	S44600001	1	ワイパーウデ	THREAD WIPER ARM ASSY	
20-3	153112001	1	ダンネジ3.57	SHOULDER SCREW, SM3.57	
20-4	021670202	1	ナット2シユ3.57	NUT, 2 SM3.57	
20-5	S49616009	1	ソレノイドボックス	SOLENOID BOX ASSY	
20-5-1	S49619001	1	イトハラソレノイド	THREAD WIPER SOLENOID ASSY	
20-5-1-1	S41204050	1	プランジャゴム	PLUNGER RUBBER	
20-5-2	062300612	4	ナベコ3X6	SCREW, PAN M3X6	
20-5-3	S41205001	1	ヒラザガネ	WASHER, PLAIN	
20-5-4	S41206001	1	イトハラバネ	THREAD WIPER SPRING	
20-5-5	S25456001	2	プランジャピン	PLUNGER PIN	
20-5-6	S42017109	1	Wソレノイドトリツケ	W-SOLENOID SETTING PLATE	
20-5-7	S49482000	1	EMロックSWハーネス	EM-LOCK SWITCH & HARNESS ASSY	
20-5-7-1	S32335100	1	SW-AVS311N	SWITCH :AVS311N	
20-5-7-2	S49466000	1	EMSWハーネス	EM-SWITCH HARNESS	
20-5-8	S37057001	1	EMスイッチスペーサ3	EM-SWITCH SPACER, 3	
20-5-9	S42018109	1	Wソレノイドカバー	WIPER SOLENOID COVER	
20-5-10	008400604	2	トラスコ4X6	SCREW, TRUSS M4X6	
20-5-11	S37806109	1	ソレノイドカバーEフタ	SOLENOID COVER LID, E	
20-5-12	008400604	2	トラスコ4X6	SCREW, TRUSS M4X6	
20-5-13	115007001	1	ザガネ	WASHER, PLAIN 13	
20-6	S41207000	1	スペーサゴム	SPACER RUBBER	
20-7	S25456001	1	プランジャピン	PLUNGER PIN	
20-8	018400632	2	アソルト4X6	BOLT, SOCKET M4X6	
20-9	100645003	2	ザガネ	WASHER	
20-10	S41657001	1	イトユルメロッドDW	TENSION RELEASE ROD, DW	
20-11	061350616	1	サラコ35X6	SCREW, FLAT M3.5X6	
20-12	062680812	2	ナベコ437-40X8	SCREW, PAN SM4.37-40X8	
20-13	156206001	1	ワイパーA	THREAD WIPER, A	
20-14	S49947000	1	コネクタVHR-5N	CONNECTOR:VHR-5N	
20-15	060670612	3	バインド357-40X6	SCREW, BIND SM3.57-40X6	
20-16	149287000	3	ナイロンクランプ	CORD HOLDER, 7N	
20-17	104449001	1	ゴムセン15.5	RUBBER CAP, 15.5	

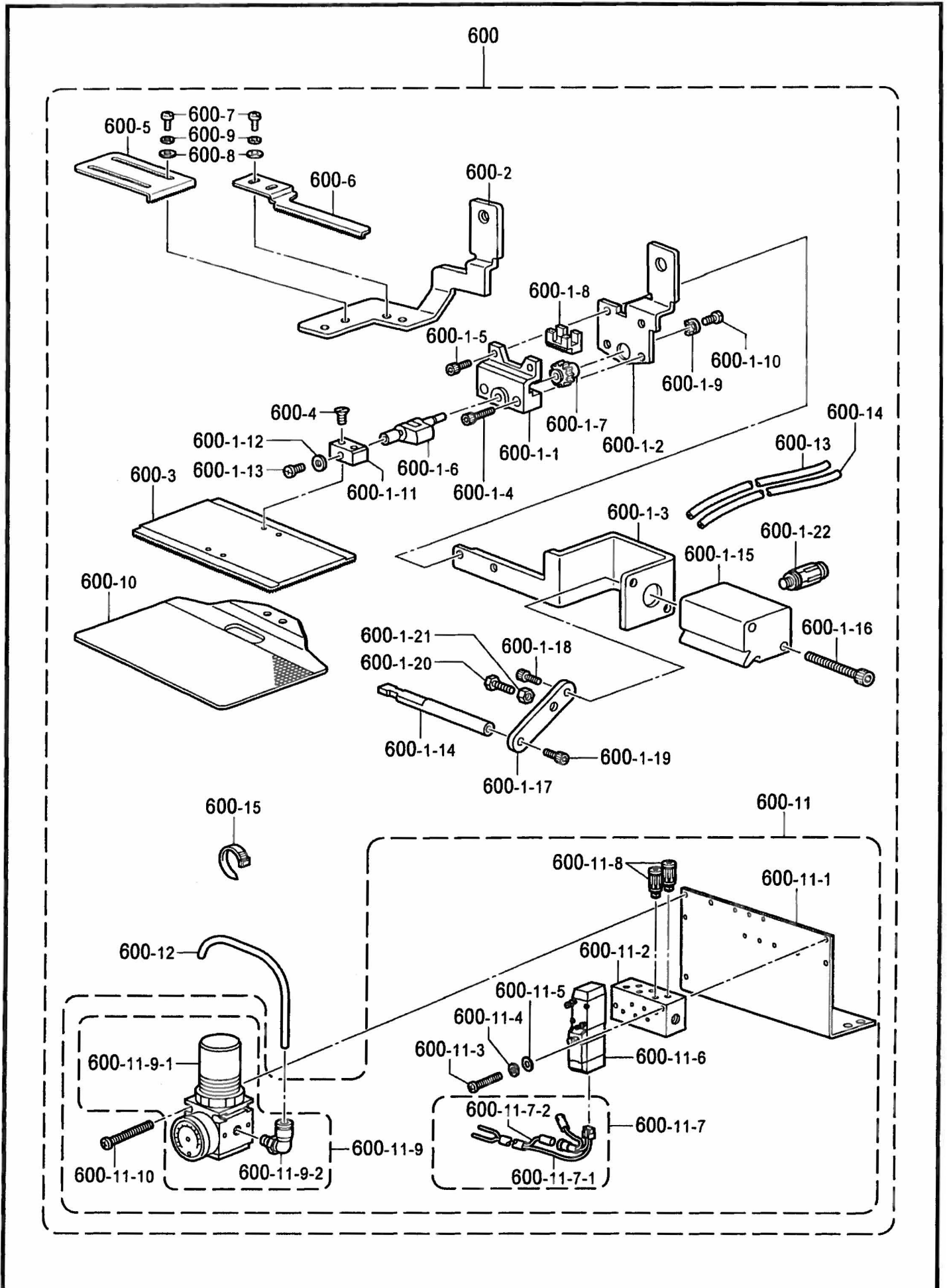

W2 . 付属装置関係 (KE-434C用オプション部品) / Attachment set (Option parts for KE=434C)

REF.NO	CODE	Q'TY	ヒンメイ	NAME OF PARTS	RM
			“ 中押工反転装置 ”	“ Inner clamping device ”	
600	S54771001	1	ハンテソウチセット	INNER CLAMP DEVICE SET	
600-1	S42007001	1	オサエクランクミ434E	WORK CLAMP CRANK ASSY, 434E	
600-1-1	S12634009	1	オサエクランクホルダA	WORK CLAMP CRANK HOLDER, A	
600-1-2	S42008001	1	オサエクランクホルダB	WORK CLAMP CRANK HOLDER, B	
600-1-3	S42019001	1	ハンテシリンダタイ	REVERSE CYLINDER BASE	
600-1-4	018301236	2	アナホルト3X12	BOLT, SOCKET M3X12	
600-1-5	018300836	2	アナホルト3X8	BOLT, SOCKET M3X8	
600-1-6	S05665001	1	オサエクランクLA	WORK CLAMP CRANK, LA	
600-1-7	154235001	1	ハンテッキヤ	REVERSE GEAR	
600-1-8	154236001	1	ハンテラツク	REVERSE RACK	
600-1-9	145087001	1	ハンテッキヤサガネ	WASHER	
600-1-10	149831101	1	アタマツキトメネジ3.18	SET SCREW, SM3.18	
600-1-11	154237001	1	オサエイトホルダL	WORK CLAMP PLATE HOLDER, L	
600-1-12	025350132	1	ヒラサガネシヨウ	WASHER, PLAIN S 3.5	
600-1-13	100242003	1	シメネジ3.57	SCREW, SM3.57-40X5	
600-1-14	S42020001	1	ハンテロツト	REVERSE ROD	
600-1-15	S12639001	1	ハンテシリンダ	REVERSE CYLINDER	
600-1-16	S12642009	2	アナホルト3X35	BOLT, SOCKET M3X35	
600-1-17	S42021001	1	ハンテシクツキテ	REVERSE SHAFT JOINT	
600-1-18	018300836	1	アナホルト3X8	BOLT, SOCKET M3X8	
600-1-19	018300836	1	アナホルト3X8	BOLT, SOCKET M3X8	
600-1-20	017501216	1	ホルト5X12	BOLT, M5X12	
600-1-21	021500216	1	2シユナツト5	NUT, 2 M5	
600-1-22	S18415101	2	ハーフユニオンQ4M5	HALF UNION :Q4M5	
600-2	S42009101	1	ソオサエアシナミメ	OUTER WORK CLAMP	
600-3	154256101	1	オサエイトプランクA	WORK CLAMP PLATE BLANK, A	
600-4	117291002	2	サラネジ3.18	SCREW, FLAT SM3.18	
600-5	154252001	1	イチキメイトL	POSITIONING PLATE, L	
600-6	154253001	1	イチキメイトR	POSITIONING PLATE, R	
600-7	062670512	4	ナベコ357-40X5	SCREW, PAN SM3.57-40X5	
600-8	025350332	4	ヒラサガネタイ3.5	WASHER, PLAIN L 3.5	
600-9	028350242	4	ハネサガネ2-3.5	WASHER, SPRING 2-3.5	
600-10	S43459001	1	オクリイタプランク434R1	FEED PLATE BLANK, 434R1	
600-11	S44745109	1	ハンテバルブ3クミ	INNER VALVE ASSY, 3	
600-11-1	S31570409	1	バルブトリツケイタ4-5H	VALVE SETTING PLATE, 4-5H	
600-11-2	S44748001	1	エアマニホルト3	AIR MANIFOLD, 3	
600-11-3	062302505	2	ナベコ3X25	SCREW, PAN M3X25	
600-11-4	028030242	2	ハネサガネ2-3	WASHER, SPRING 2-3	
600-11-5	025030232	2	ヒラサガネチユウ3	WASHER, PLAIN M 3	
600-11-6	S43683001	1	ソレノイドバルブ	SOLENOID VALVE	
600-11-7	S43696100	1	バルブハーネスX1クミ	VALVE HARNESS ASSY, X1	
600-11-7-1	S44746100	1	ツイカバルブハーネス	VALVE HARNESS	
600-11-7-2	S44750100	1	ツイカバルブハーネス24V	VALVE HARNESS, 24V	
600-11-8	S18415101	2	ハーフユニオンQ4M5	HALF UNION :Q4M5	
600-11-9	S45252000	1	レギュレータクミ	REGULATOR ASSY	
600-11-9-1	S45253000	1	レギュレータ	REGULATOR	
600-11-9-2	S45254000	2	ツキテ3109-4-10	JOINT, 3109-4-10	
600-11-10	062404005	2	ナベコ4X40	SCREW, PAN M4X40	
600-12	S28741000	1	エアチューブ	AIR TUBE, 4 L=300	
600-13	S53118001	1	ナイロンチューブ	AIR TUBE, RV-3A L=1600	
600-14	S53118002	1	ナイロンチューブ	AIR TUBE, RV-3B L=1600	
600-15	228475000	3	ケツソクバンド1.9X80	TYING BAND 1.9X80	

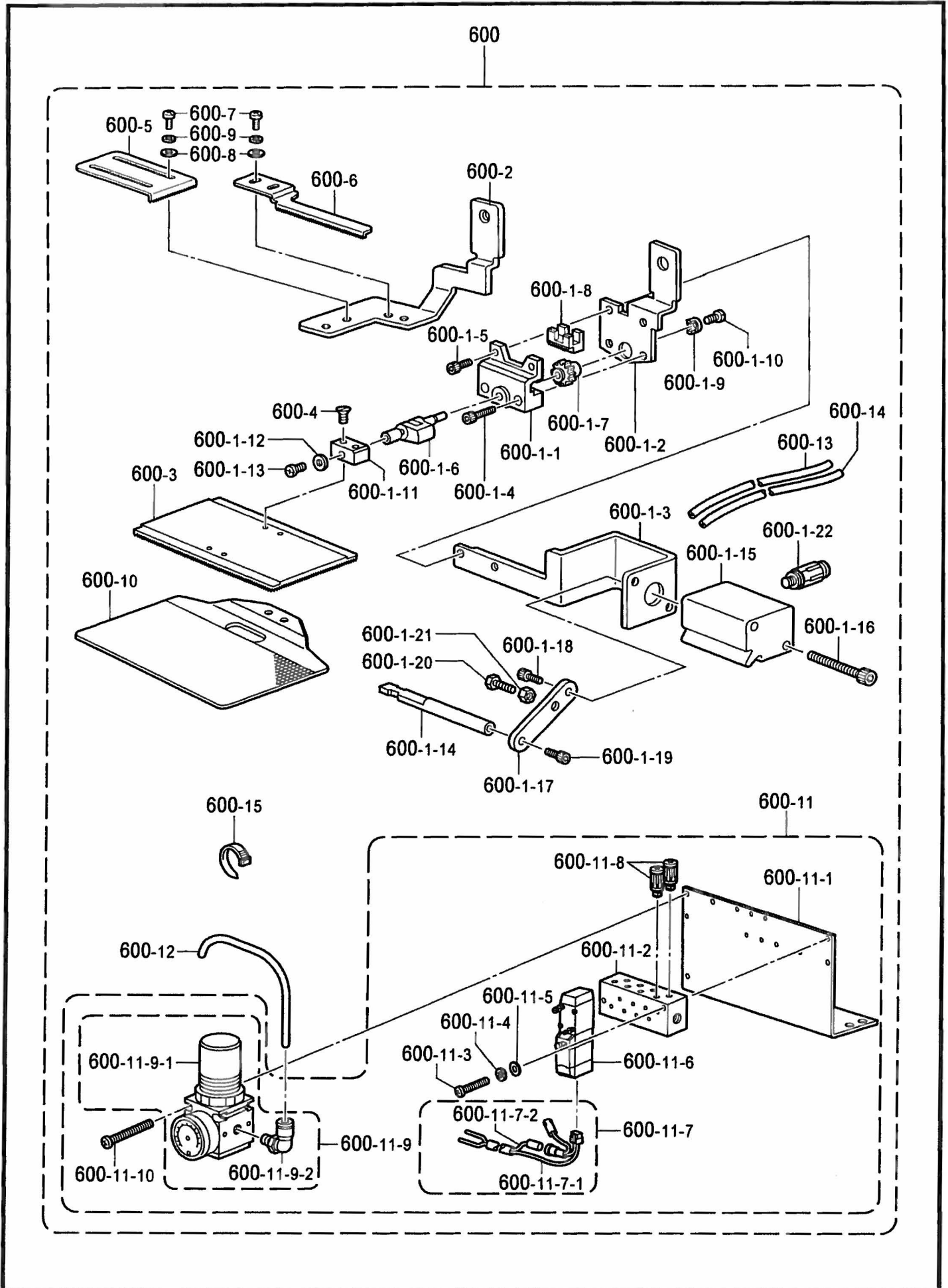

W3 . 付属装置関係 (KE-435C用オプション部品) / Attachment set (Option parts for KE=435C)

REF.NO	CODE	Q'TY	ヒンメイ	NAME OF PARTS	RM
600	SA0709001	1	“ 中押工反転装置 ”	“ Inner clamping device ”	
600-1	S42007001	1	ハンテソウチセット	INNER CLAMP DEVICE SET	
600-1-1	S12634009	1	オサエクランククミ434E	WORK CLAMP CRANK ASSY, 434E	
600-1-2	S42008001	1	オサエクランクホルダA	WORK CLAMP CRANK HOLDER, A	
600-1-3	S42019001	1	オサエクランクホルダB	WORK CLAMP CRANK HOLDER, B	
600-1-4	018301236	2	ハンテシリンダダイ	REVERSE CYLINDER BASE	
600-1-5	018300836	2	アナホルト3X12	BOLT, SOCKET M3X12	
600-1-6	S05665001	2	アナホルト3X8	BOLT, SOCKET M3X8	
600-1-7	154235001	1	オサエクランクLA	WORK CLAMP CRANK, LA	
600-1-8	154236001	1	ハンテギヤ	REVERSE GEAR	
600-1-9	145087001	1	ハンテラック	REVERSE RACK	
600-1-10	149831101	1	ハンテギヤサガネ	WASHER	
600-1-11	154237001	1	アタマツキトメネジ3.18	SET SCREW, SM3.18	
600-1-12	025350132	1	オサエイタホルダL	WORK CLAMP PLATE HOLDER, L	
600-1-13	100242003	1	ヒラサガネシヨウ	WASHER, PLAIN S 3.5	
600-1-14	S42020001	1	シメネジ3.57	SCREW, SM3.57-40X5	
600-1-15	S12639001	1	ハンテロツト	REVERSE ROD	
600-1-16	S12642009	1	ハンテシリンダ	REVERSE CYLINDER	
600-1-17	S42021001	2	アナホルト3X35	BOLT, SOCKET M3X35	
600-1-18	018300836	1	ハンテジクツキテ	REVERSE SHAFT JOINT	
600-1-19	018300836	1	アナホルト3X8	BOLT, SOCKET M3X8	
600-1-20	017501216	1	アナホルト3X8	BOLT, SOCKET M3X8	
600-1-21	021500216	1	ホルト5X12	BOLT, M5X12	
600-1-22	S18415101	1	2シユナツト5	NUT, 2 M5	
600-2	S42009101	2	ハーフユニオンQ4M5	HALF UNION :Q4M5	
600-3	154256101	1	ソトオサエアシナミメ	OUTER WORK CLAMP	
600-4	117291002	1	オサエイタブランクA	WORK CLAMP PLATE BLANK, A	
600-5	154252001	2	サラネジ3.18	SCREW, FLAT SM3.18	
600-6	154253001	1	イチキメイトL	POSITIONING PLATE, L	
600-7	062670512	1	イチキメイトR	POSITIONING PLATE, R	
600-8	025350332	4	ナベコ357-40X5	SCREW, PAN SM3.57-40X5	
600-9	028350242	4	ヒラサガネダ13.5	WASHER, PLAIN L 3.5	
600-10	S43459001	4	ハネサガネ2-3.5	WASHER, SPRING 2-3.5	
600-11	SA0048001	1	オクリイタブランク434R1	FEED PLATE BLANK, 434R1	
600-11-1	S31570409	1	ハンテバルブ4クミ	REVERSE VALVE ASSY, 4	
600-11-2	S44749001	1	バルブトリツケイタ4-5H	VALVE SETTING PLATE, 4-5H	
600-11-3	S44749001	1	エアマニホルト4	AIR MANIFOLD, 4	
600-11-4	062302505	2	ナベコ3X25	SCREW, PAN M3X25	
600-11-5	028030242	2	ハネサガネ2-3	WASHER, SPRING 2-3	
600-11-6	025030232	2	ヒラサガネチユウ3	WASHER, PLAIN M 3	
600-11-7	S43683001	1	ソレノイドバルブ	SOLENOID VALVE	
600-11-7-1	S43696100	1	バルブハーネスX1クミ	VALVE HARNESS ASSY, X1	
600-11-7-2	S44746100	1	ツイカバルブハーネス	VALVE HARNESS	
600-11-8	S44750100	1	ツイカバルブハーネス24V	VALVE HARNESS, 24V	
600-11-9	S18415101	2	ハーフユニオンQ4M5	HALF UNION :Q4M5	
600-11-9-1	S45252000	1	レギュレータクミ	REGULATOR ASSY	
600-11-9-2	S45253000	1	レギュレータ	REGULATOR	
600-11-10	S45254000	2	ツキテ3109-4-10	JOINT, 3109-4-10	
600-12	062404005	2	ナベコ4X40	SCREW, PAN M4X40	
600-13	S28741000	1	エアチューブ	AIR TUBE, 4 L=300	
600-14	S53118001	1	ナイロンチューブ	AIR TUBE, RV-3A L=1600	
600-15	S53118002	1	ナイロンチューブ	AIR TUBE, RV-3B L=1600	
600-15	228475000	3	ケツソクバンド1.9X80	TYING BAND 1.9X80	

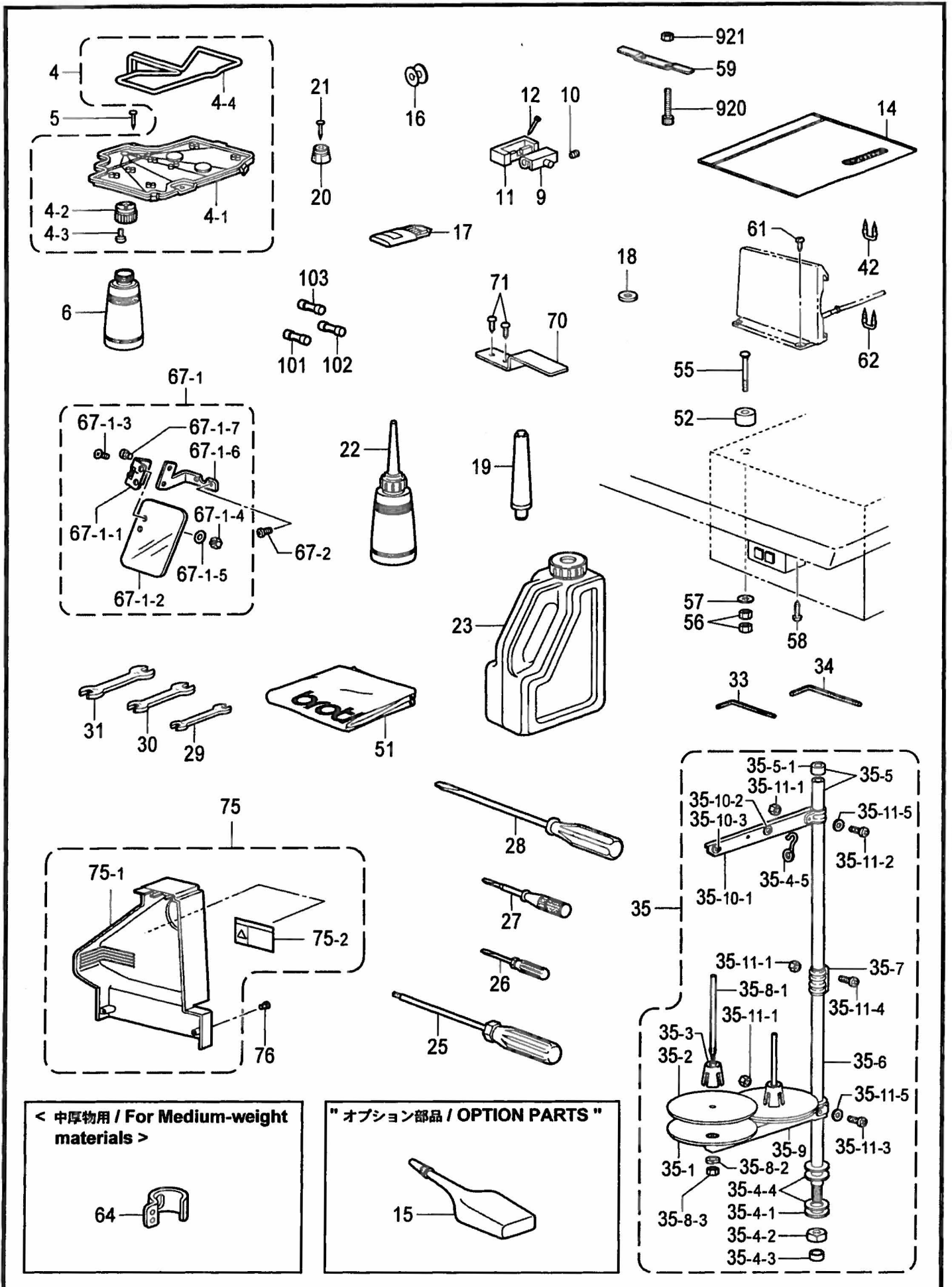

Z. 付属品関係 / Accessories

REF.NO	CODE	Q'TY	ヒンメイ	NAME OF PARTS	RM
4	S38039209	1	オイルパンクミ	OIL PAN ASSY	
4-1	S38040209	1	オイルパン	OIL PAN	
4-2	154467001	1	ハイユキヤツフ	DUST OILER	
4-3	037301215	2	Vナヘ`タツピン3X12	TAPPING SCREW, PAN V M3X12	
4-4	S18093100	1	クミヒモ4X4	WICK, 4X4 L=1100	
5	109714000	5	クギ	NAIL	
6	114486002	1	ホ`リオイラータイ	OILER	
9	143882001	2	トウフ`ヒンジ	HEAD HINGE	
10	014760632	2	アナクホ`ミ595-28X6	SET SCREW, SOCKET SM5.95-28X6	
11	S49603000	2	トウフ`ヒンジウケゴム	RUBBER CUSHION	
12	109714000	4	クギ	NAIL	
14	122991001	1	フゾク`ヒンホ`リフクロ	ACCESSORY BAG	
16	*	3	ホ`ピン	BOBBIN	
17	*	1	ハリ4コイリクミ	NEEDLE 4 PIECE ASSY	
18	S10208001	1	イト`ウハカンザ` <t=0.4>	MOVABLE KNIFE SPACER <t=0.4>	
18	S10208002	1	イト`ウハカンザ` <t=0.5>	MOVABLE KNIFE SPACER <t=0.5>	
18	S10208003	1	イト`ウハカンザ` <t=0.6>	MOVABLE KNIFE SPACER <t=0.6>	
19	S38045109	1	マクラクミ	HEAD REST ASSY	
20	S49604000	2	トウフ`ウケゴム	RUBBER CUSHION	
21	109714000	2	クギ	NAIL	
22	114483002	1	ホ`リオイラークミ	OILER ASSY	
23	S55663001	1	オイルタンククミ	OIL TANK ASSY	
25	149173001	1	6カクホ`ウネジ`マワシ3	SCREW-DRIVER, HEXAGONAL 3	
26	142443001	1	ネジ`マワシ1.9X52	SCREW-DRIVER, 1.9X52	
27	118837001	1	ネジ`マワシ3.4X70	SCREW-DRIVER, 3.4X70	
28	101572101	1	ネジ`マワシ5.5X190	SCREW-DRIVER, 5.5X190	
29	107779001	1	スパナ`6X7	WRENCH, 6X7	
30	100887001	1	スパナ`8X9	WRENCH, 8X9	
31	107780001	1	スパナ`10X12	WRENCH, 10X12	
33	142721001	1	6カクホ`ウスパナ`3	HEXAGONAL WRENCH, 3	
34	118064001	1	6カクホ`ウスパナ`4	HEXAGONAL WRENCH, 4	
35	S02763402	1	イトタテ`ダイクミ2DR	COTTON STAND ASSY, 2DR	
35-1	S51283001	2	ウケザラ	SPOOL STAND BASE	
35-2	150182000	2	スプール`マット	SPOOL MAT	
35-3	S51282001	2	スプール`クッション	SPOOL CUSHION	
35-4	S02777001	1	パイプ`Dネジ`セットB	PIPE (D) SCREW SET, B	
35-4-1	150206002	1	ヒラサ`ガネ16	WASHER, PLAIN 16	
35-4-2	S38648001	1	6カクナツト`U5/8	NUT, U5/8-28	
35-4-3	150174000	1	コラム`キャツフ	COLUMN CAP	
35-4-4	S01005000	2	イトタテ`ゴム	RUBBER WASHER	
35-4-5	S02747101	1	イトカケ`バネ	SPRING	
35-5	S40640001	1	コラム`パイプ`キャツフ`ツキ	COLUMN PIPE W/CAP	
35-5-1	150174000	1	コラム`キャツフ	COLUMN CAP	
35-6	156112003	1	コラム`パイプ`D	COLUMN PIPE, D	
35-7	150173003	1	コラム`ジョイント	COLUMN JOINT	
35-8	S21798001	2	スプール`ネジ`セット	SPOOL & SCREW SET	
35-8-1	150179002	2	スプール`ジク`B	SPOOL SHAFT, B	
35-8-2	028050246	2	バネサ`ガネ2-5	WASHER, SPRING 2-5	
35-8-3	021500106	2	1`シュナツト`5	NUT, 1 M5	
35-9	S02778002	1	スプール`ホルダ`-2	SPOOL HOLDER, 2	
35-10	S02786002	1	スレツト`ハンガ`-クミ2	THREAD HANGER ASSY, 2	
35-10-1	S02787002	1	スレツト`ハンガ`-2	THREAD HANGER, 2	
35-10-2	150183000	2	イトカケ`ハンガ`-ダイ	THREAD HANGER BASE	
35-10-3	142990001	2	スレツト`ブツ`シュ	THREAD BUSH	
35-11	S40641001	1	スプール`ジク`ネジ`セットA	SPOOL SHAFT & SCREW SET, A	
35-11-1	021500106	4	1`シュナツト`5	NUT, 1 M5	
35-11-2	062501406	1	ナヘ`コ5X14	SCREW, PAN M5X14	

KE-434C/435C-910

* 付属品の明細は変更することがあります。

* The details of included accessories are subject to change.

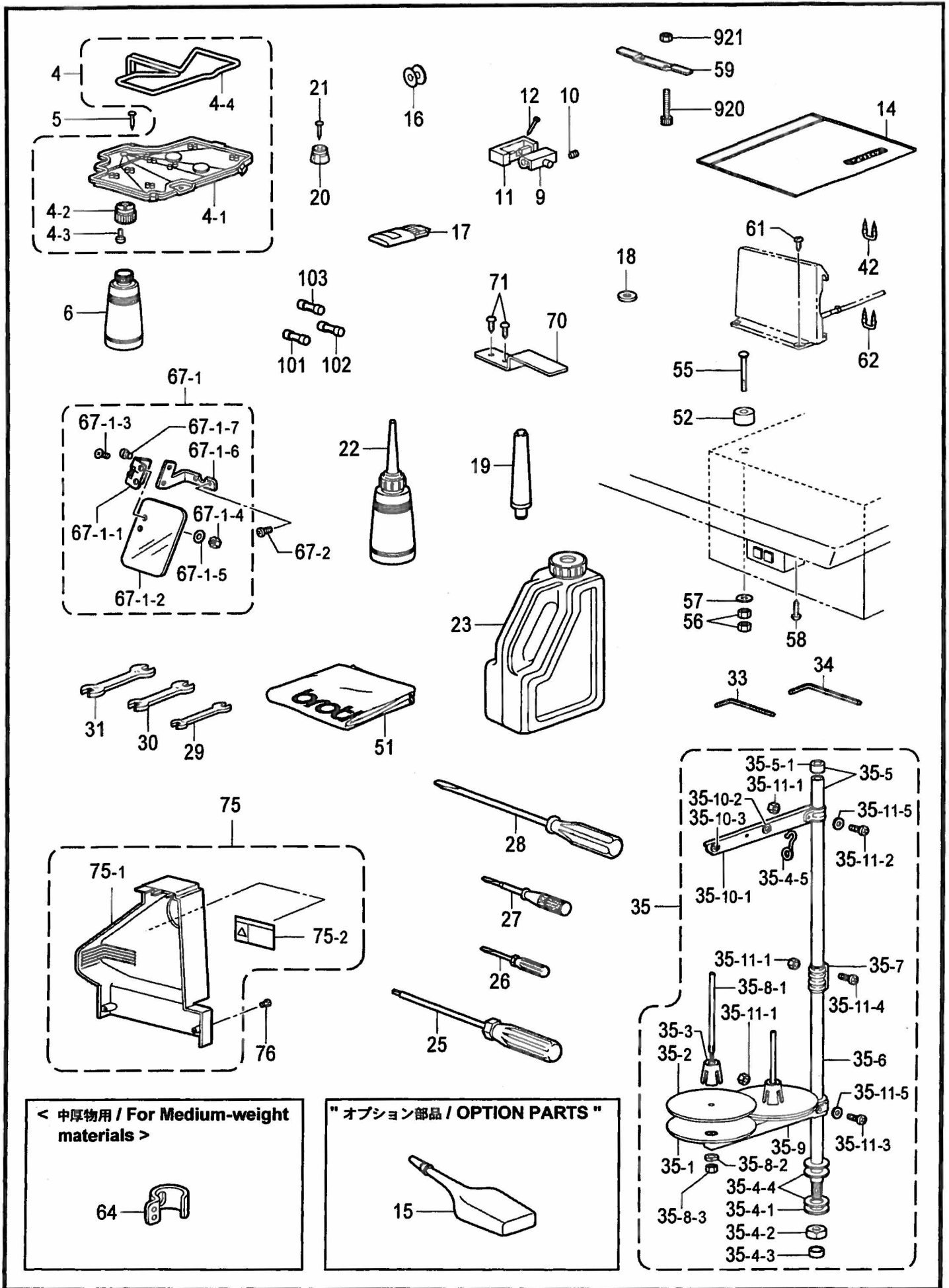

Z. 付属品関係 / Accessories

REF.NO	CODE	Q'TY	ヒンメイ	NAME OF PARTS	RM
35-11-3	S59931001	1	ナベコM5X32	SCREW, PAN M5X32	
35-11-4	062501406	2	ナベコ5X14	SCREW, PAN M5X14	
35-11-5	026050136	2	ヒラザガネコガタ5	WASHER, PLAIN S 5	
42	200190001	5	ステツブル	STAPLE	
51	144226001	1	トウブカバ-	HEAD COVER	
			<コントロールBox取付用>	<Setting the control box>	
52	S33006001	4	モータスペーサ	MOTOR SPACER	
55	133740006	4	カクネホルト6X70	BOLT, SQUARE M6X70	
56	021060106	8	1シユナツト6	NUT, 1 M6	
57	025060336	4	ヒラザガネダ16	WASHER, PLAIN L 6	
			<電源SW取付用>	<Setting the power switch>	
58	032461606	2	+2マルモク45X16	WOOD SCREW, ROUND 2 M45X16	
59	S38044001	1	ヒンジオサエ	HINGE PRESSER	
61	031412506	4	+2マルモク41X25	WOOD SCREW, ROUND 2 M41X25	
62	200190001	3	ステツブル	STAPLE, 10X20	
			<中厚物用>	<For Medium-weight materials>	
64	S41222101	1	ハリホウイアンナイB	NEEDLE BAR THREAD GUIDE, B	
67-1	SA4152001	1	アイガードクミ	EYE GUARD ASSY	
67-1-1	S44483001	1	チヨウバンクミ	HINGE ASSY	
67-1-2	S44485001	1	アイガード	EYE GUARD	
67-1-3	061300816	2	サヲコ3X8	SCREW, FLAT M3X8	
67-1-4	021300106	2	1シユナツト3	NUT, 1 M3	
67-1-5	026030236	2	ヒラザガネミガキ 3	WASHER, PLAIN M 3	
67-1-6	SA4104001	1	アイガードホルダー-A	EYE GUARD HOLDER, A	
67-1-7	062300506	2	ナベコ3X5	SCREW, PAN M3X5	
67-2	062671016	2	ナベコ357-40X10	SCREW, PAN SM3.57-40X10	
70	S55633001	1	スイッチオシタ	SWITCHING PLATE	
71	032422003	2	+マルモクネジ4.1X20	WOOD SCREW, ROUND M4.1X20	
			<国内用>	<For Japan only>	
75	S55311001	1	ベルトカバーIMクミ		
75-1	S51097000	1	ベルトカバーIM		
75-2	S38350001	1	ソウサチユウイラベル.W		
			<輸出用>	<For Export>	
75	S55311002	1	ベルトカバーIMクミ	BELT COVER ASSY, IM	
75-1	S51097000	1	ベルトカバーIM	BELT COVER, IM	
75-2	S38349001	1	ソウサチユウイラベル.エイ	LABEL, OPERATION ENG.	
76	062401006	2	ナベコ4X10	SCREW, PAN M4X10	
101	S08030000	1	GEヒューズ5AFB	FUSE, 5A :FB	
102	153242000	1	ヒューズ6A	FUSE, 6A	
103	S48580000	1	GFUSE7AFB	FUSE, 7A :FB	
920	018405032	2	アナホルト4X50	BOLT, SOCKET M4X50	
921	021400102	2	ナツト1シユ4	NUT, 1 M4	
			" オプション部品 "	" OPTION PARTS "	
15	S06706001	1	シリコンオイル	SILICONE OIL	

KE-434C/435C-910

* 付属品の明細は変更することがあります。

* The details of included accessories are subject to change.











Sp1 . 仕様別部品一覧表 / Different parts list

KE-434C, KE-435Cには下記部品が用意されていますので幅広い用途にご活用ください。

The following are standard gauge parts according to each specification.



◎ ☆の部品は、BAS-311F プログラム式電子ミシンと共通です。



◎In the following table, parts marked ☆ are common with the BAS-311F.

仕様 Spec.	KE-434C			KE-435C
	434C-1	434C-2	434C-option	
品名 Part name	中厚物 Medium-weight materials	厚物 Heavy-weight materials	極厚物 Extra heavy-weight materials	厚物 Heavy-weight materials
(J-53) 針穴板 Needle hole plate 	(φ2.2) S49980-001 < FM >	(φ2.6) S10212-101 < E >		(φ2.6) S10212-101 < E >
(E-24) ボビンケース組 Bobbin case assy 	159610-301 < A >	152690-401 < B >		152690-401 < B >
	S59221-001 < LC >			S59221-001 < LC >
(E-24-1) ボビンケース調子ばね Tension spring 	154339-101 < A >	154340-101 < B >		154340-101 < B >
(E-24-2) ボビンケースばねねじ Screw 	154341-001			154341-001
(E-24-3) 空転防止ばね Spring, anti-spin 	159612-001 < A >	154342-001 < B >		154342-001 < B >
(E-25) ボビン Bobbin 	159613-051		154663-001 < B >	159613-051
	S44633-001 < LAN >			S44633-001 < LAN >
(E-22) 中がま箱組 Shuttle hook assy, w/box 	SA1881-001 < A >	SA1882-001 < B >		SA1882-001 < B >
	SA2173-001 < LF > ☆	SA1890-001 < LG > ☆		SA1890-001 < LG > ☆
(E-21) 大がま Shuttle race body 	152682-101 < A >	152686-101 < B >		152686-101 < B >
(G-14) 糸調子ばね Spring, tension 	104525-001	107606-001	S06548-001 < C >	107606-001
(G-10) 糸取りばね Thread take-up spring 	145519-001	144588-001 < B >		144588-001 < B >

KE-434C/435C-Sp

Sp2 . 仕様別部品一覧表 / Different parts list

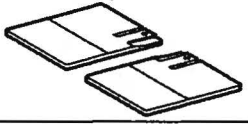
仕様 Spec. 品名 Part name	KE-434C			KE-435C
	434C-1 中厚物 Medium-weight materials	434C-2 厚物 Heavy-weight materials	434C-option 極厚物 Extra heavy-weight materials	
(G-25) 針棒糸案内 Thread guide, ;n-bar 	S41222-101 < B >	152890-001 < A >	S02439-001 < B >	S02438-001 < A > ☆
(Z-17) ミシン針組 Needle assy	SA1752-014 < #14 >	SA1579-019 < #19 >	SA1645-025 < #25 >	SA1579-019 < #19 >
	反転用 / Inner clamping device DP×17 < #14 > SA1645-014			
(B-26) 針 Needle 	DP×5 < #14 > 107415-014	DP×17NY < #19 > S37928-019	DP×17 < #25 > 145646-025	DP×17NY < #19 > S37928-019
	反転用 / Inner clamping device DP×17 < #14 > 145646-014			

仕様 Spec. 品名 Part name	KE-434C			KE-435C
	434C-1 ブランク中厚物用 Blank for Medium -weight materials	434C-2 ブランク厚物用 Blank for Heavy -weight materials	434C-option ブランク反転用 Blank for Inner clamping device	
(C6-200-1, 200-2) 押えブランク Work clamp blank 	434-1L S42031-001	434-2L S42033-001	154256-101 < A >	434E SF-2L S46545-001
	434-1R S42030-001	434-2R S42032-001		434E SF-2R S46544-001
(C6-100) 送り板ブランク Feed plate blank 	434-1 S42034-001	434-2 S42035-001	434-R1 S43459-001	434E SF-2 S44942-001

KE-434C/435C-Sp

Ga1 . ゲージ部品一覧表 / Gauge parts List

<ゲージ部品>

オプションのゲージ部品には次のものがあります。押えと送り板は、上下の組合わせになります。

< Gauge parts >



The following are provided as optional gauge parts.

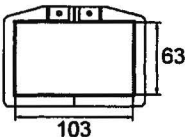
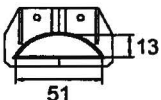
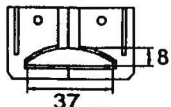
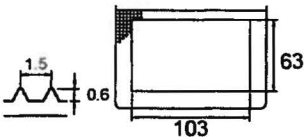
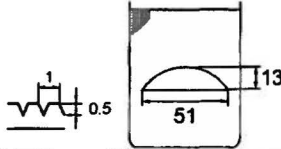
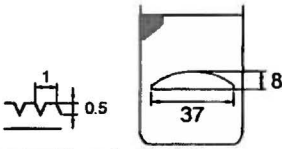
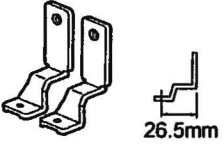
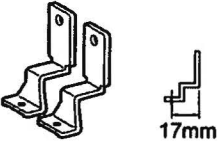
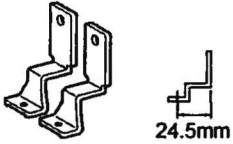
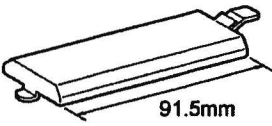
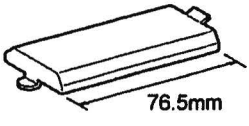
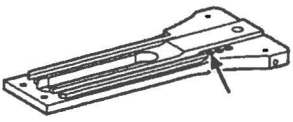
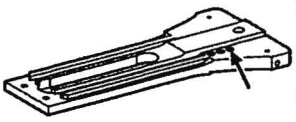
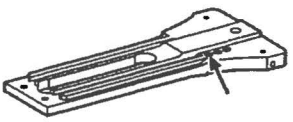

Each work clamp pair are used in combination with the feed plate directly below them.

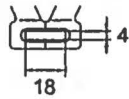
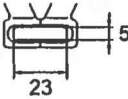
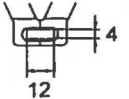
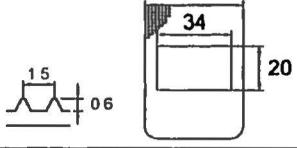
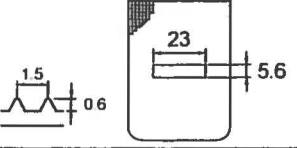
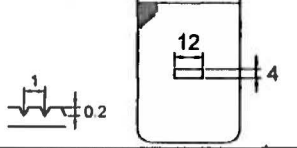
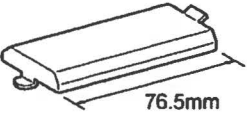
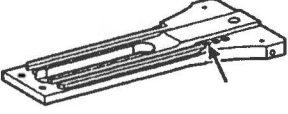
仕様 Spec.	KE-434E		
	エア Pneumatic Type	電磁 Solenoid Type	電磁 Solenoid Type
	< 100 X 60 >		< 48 X 10 X R30 >
R	153493-001	S23377-001 (519)	S27836-001 (895)
L	153498-001	S23378-001 (519)	S27837-001 (895)
(C6-210) 押え Work clamp			
(C6-110) 送り板 Feed plate	153503-001 	S23379-001 (519) 	S27838-001 (895) 
押え足 Work clamp	S41660-001 (エア /Air)	153372-001 (L)	153368-001 (S)
			
送り台カバー Feed guide cover	153391-001 (L)		153392-001 (S)
			
押え腕の 取付け位置 Installation position of work clamp arm			

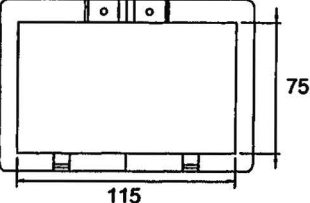
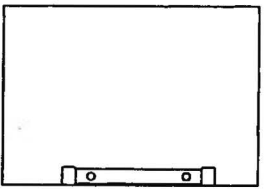

Ga1 . ゲージ部品一覧表 / Gauge parts List

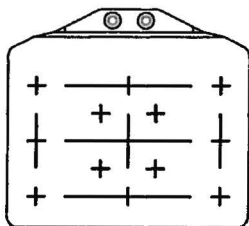
仕様 Spec.	KE-434E		
	電磁 Solenoid Type		
	< Bar tack "16 X 2" >	< Bar tack "20 X 3" >	< Bar tack "10 X 2" >
R	156085-001 (M)	156082-001 (L)	156088-001 (S)
L	156086-001 (M)	156083-001 (L)	156089-001 (S)
(C6-210) 押え Work clamp			
(C6-110) 送り板 Feed plate	156087-001 (M) 	156084-001 (L) 	156090-001 (S) 
送り台カバー Feed guide cover	153392-001 (S) 		
押え腕の 取付け位置 Installation position of work clamp arm			





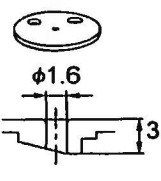
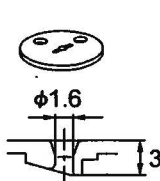
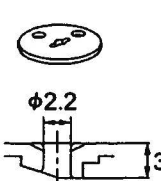
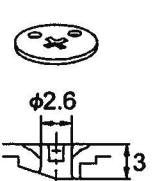
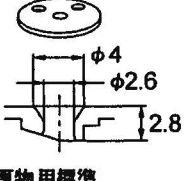
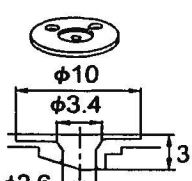
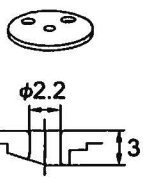
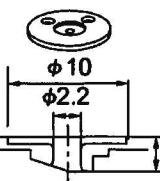

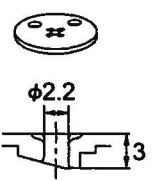
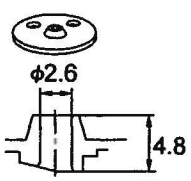
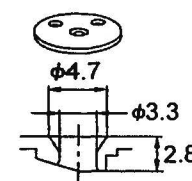
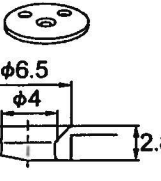
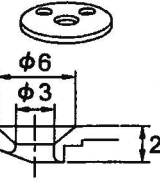
仕様 Spec.	KE-435C		
(C6-210-7-1, 210-7-2) 押え Work clamp	S44940-001 (434E SF)		
	S44941-001 (434E SF)		
			
(C6-302) 送り板 Feed plate	S43990-001 t = 0.5	S43991-001 t = 1.0	S43992-001 t = 2.0
			
送り台カバー Feed guide cover	153391-001 (L) 		

(C6-905) ゲージ組 434E MK2 / Gauge assy, 434E MK2 S54984-001
原点基準板 / Home position standard plate S52100-001 
送り板締めねじ / Screw, w/socket SM4.37 S49955-101 

KE-434C/435C-Ga

(J-53) 針穴板 / Needle hole plate											
A	S10211-001	A-F	S51449-001	BZ	S41013-001	D	S29997-001	E	S10212-101	ED	S30925-001
									 (厚物用標準 / For Heavy -weight materials)		
F	S10213-001	FD	S30926-001	FM	S49980-001	FZ	S59620-001	H	S30450-001	L	S25127-001
					 (中厚物用標準 / For Medium -weight materials)						
M	S34348-001	3ザグリ		S40217-001							
											

Wa. 警告ラベル / Warning labels

警告ラベル / Warning labels	品名 / Name of parts	Size(mm)	Code
	電撃ラベル・和	40×64	S38353-101
	Label, elec. shock 4 lang.	45×118	S38352-101
	操作注意ラベル・和	40×64	S38350-001
	Label, operation Eng.	40×64	S38349-001
	PE マーク Label, PE	7.5×12.5	S37059-001
	アースマーク Label, grounding	φ 12	S37060-001

索引 / INDEX

CODE	REF.NO	Page	CODE	REF.NO	Page	CODE	REF.NO	Page	CODE	REF.NO	Page
004400603	V1 -1-1-1-5	74	018300836	W3-600-1-19	86	025040236	V3 -1-3-12	78	032422003	R1 -22	62
	V2 -1-2-1-3	76	018301236	C5 -92-12-4	20	025050236	V1 -1-1-9	74		R2 -22	66
	V3 -1-3-1-5	78		W2 -600-1-4	84		V2 -1-2-9	76		Z -71	90
008400604	K -513	42		W3 -600-1-4	86		V3 -1-3-9	78	032461606	Z -58	90
	K -515	42	018400632	C1 -34	10	025060232	A -406	2	037301215	Z -4-3	88
	Q1 -1-22	54		C4 -91-11	18		C2 -48	14	047401442	M -6	50
	W1 -20-5-10	82		C5 -92-11	20		C3 -48	16	048030342	K -12	42
	W1 -20-5-12	82		K -510	42	025060236	Q2 -5	60		C4 -91-20	18
011679312	A -410	4		W1 -20-8	82	025060336	Z -57	90		C5 -92-21	20
014680432	C4 -91-6-2	18	018401236	B2 -30-1-4	8	025080132	A -35	2		D2 -725	26
	C5 -92-6-2	20		V1 -1-1-10	74	025080232	B2 -39	8		K -4	42
014680632	E -3	28		V2 -1-2-10	76	025080236	V1 -1-1-6	74		L -15	46
	H -1-9	36		V3 -1-3-10	78		V2 -1-2-6	76		L -707	46
	J -8-2	38	018402532	S -3-2	68		V3 -1-3-6	78		M -19	50
014710532	K -14-1	42	018405032	Z -920	90		V4 -2-1-4	80	048050342	C4 -91-8	18
014760632	C1 -1-7	10	018500832	C2 -90-2-14	14		V4 -2-4-8	80		C5 -92-8	20
	C1 -6	10		C3 -90-5-13	16	025350132	C5-92-12-12	20		H -1-10	36
	C1 -7-4	10	018501032	C4 -50	18		W2-600-1-12	84	048050346	V1-1-1-1-13	74
	C1 -11	10		C5 -50	20		W3-600-1-12	86		V2-1-2-1-12	76
	C1 -14	10	018501036	D1 -301	24	025350236	A -702	4		V3-1-3-1-14	78
	C1 -20	10		V1 -1-1-7	74	025350332	C5 -604	20	048060342	J -32	38
	C1 -26	10		V2 -1-2-7	76		M -16	50		K -9	42
	C1 -29	10		V3 -1-3-7	78		W2 -600-8	84	048070342	E -18	28
	C1 -44-11	12	018501232	E -20	28		W3 -600-8	86		J -19	38
	C4 -91-9	18	018501432	D1 -26	24	025680132	B2 -30-5	8	048100142	H -1-4	36
	C5 -92-9	20	021060102	B2 -43	8	025680232	C1 -54	12	048110142	C2 -90-2-6	14
	D1 -13	24	021060106	Q2 -6	60		F -8	32		C3 -90-5-5	16
	E -7	28		Z -56	90		H -1-27	36	048150142	B1 -9	6
	E -10	28	021300106	Z -67-1-4	90		H -4	36	048180142	C1 -9	10
	E -15	28	021300206	V4 -2-1-10	80	025750132	L -706	46	048200142	D1 -303	24
	G -28	34	021400102	Z -921	90	025770232	E -32	28	052400606	V1-1-1-1-14	74
	J -33	38	021400106	Q2 -52	60		K -3	42		V2-1-2-1-13	76
	K -5	42		S -40-10	68	026030236	Z -67-1-5	90		V3-1-3-1-15	78
	K -14-2	42	021400206	Q1 -1-6	54	026040236	S -40-8	68	052400806	V4 -2-1-11	80
	Z -10	88	021500106	R1 -21	62	026050136	Z -35-11-5	90	060400616	S -37	68
014770632	J -2	38		R2 -21	66	028030242	R1 -500-7	62	060501016	D1 -22	24
	J -23	38		Z -35-8-3	88		R1 -600-10	62		S -15	68
	B1 -14	6		Z -35-11-1	88		R2 -700-10	66	060670512	F -16	32
	E -13-1	28	021500216	C5-92-12-21	20		W2-600-11-4	84	060670612	A -706	4
014780632	B1 -5	6		W2-600-1-21	84	028040246	W3-600-11-4	86		G -2-1	34
	B1 -17	6		W3-600-1-21	86		B2 -30-1-5	8		G -4	34
017082206	V4 -2-4-5	80	021660102	K -705	44		V1 -1-1-11	74		G -6	34
017501216	C5-92-12-20	20	021670102	M -10-1	50		V2 -1-2-11	76		S -31	68
	W2-600-1-20	84		M -10-2	50		V3 -1-3-11	78		S -35	68
	W3-600-1-20	86	021670202	K -503	42	028050246	V1 -1-1-8	74		S -36	68
017680512	A -15	2		W1 -20-4	82		V2 -1-2-8	76		W1 -20-15	82
	B2 -49	8	021680202	H -1-24	36		V3 -1-3-8	78	060671212	A -18-1	2
017751412	D2 -709	26	021750102	D2 -707	26		Z -35-8-2	88	060680712	A -408	4
018061436	Q2 -4	60	025030232	R1 -500-8	62	028060246	Q2 -7	60		C1 -32	10
018062032	B2 -41	8		R1 -600-11	64	028080240	V4 -2-4-7	80		D1 -24	24
018062532	B2 -42	8		R2 -700-11	66	028080242	B2 -38	8	060681212	D1 -20	24
018082536	V1 -1-1-4	74		W2-600-11-5	84	028080246	V1 -1-1-5	74		J -5	38
	V2 -1-2-4	76		W3-600-11-5	86		V2 -1-2-5	76		L -725	48
	V3 -1-3-4	78	025030236	V4 -2-1-9	80		V3 -1-3-5	78	061300816	Z -67-1-3	90
018083032	B2 -37	8	025040232	C1 -35	10	028350242	C5 -605	20	061350616	K -517	42
018300836	C5 -92-12-5	20		C4 -91-10	18		L -5-6	46		W1 -20-11	82
	C5-92-12-18	20		C5 -92-10	20		M -15	50	062020806	S -40-4	68
	C5-92-12-19	20	025040236	Q2 -51	60		W2 -600-9	84	062300506	Z -67-1-7	90
	W2-600-1-5	84		V1-1-1-1-15	74		W3 -600-9	86	062300612	S -502	70
	W2-600-1-18	84		V1 -1-1-12	74	028680242	F -9	32		W1 -20-5-2	82
	W2-600-1-19	84		V2-1-2-1-14	76		J -22-6	38	062300616	K -606	44
	W3-600-1-5	86		V2 -1-2-12	76		L -713	48	062300806	S -8	68
	W3-600-1-18	86		V3-1-3-1-16	78	031412506	Z -61	90		S -9	68

CODE	REF.NO	Page	CODE	REF.NO	Page	CODE	REF.NO	Page	CODE	REF.NO	Page
062300806	T - 1-2	72	070688850	C1 - 22	10	101572101	Z - 28	88	116920001	B1 - 8	6
062301205	V2 - 1-2-1-6	76	071047650	C1 - 5	10	101706001	C1 - 3-2	10	116922001	G - 12	34
	V3 - 1-3-1-8	78	072630260	B1 - 7	6		E - 6-1	28	117291002	C5 - 600	20
062302505	W2-600-11-3	84	081003670	E - 12	28	102630001	B1 - 18	6		W2 - 600-4	84
	W3-600-11-3	86		E - 17	28	103810002	E - 31	28		W3 - 600-4	86
062302506	R1 - 500-6	62	087310815	T - 1-1-5	72	104449001	A - 11	2	117934001	A - 6	2
	R1 - 600-9	62	087311015	T - 1-1-9	72		A - 712	4		A - 17-1-3	2
	R2 - 700-9	66	091170009	P - 1-5	52		A - 713	4		A - 17-2-3	2
	V1 - 1-1-1-8	74	093650008	P - 1-3	52		K - 518	42	117936001	A - 700	4
	V3 - 1-3-1-21	78	093650032	P - 1-4	52		W1 - 20-17	82		V1 - 1-1-1-16	74
062400616	S - 40-6	68	0A4301005	P - 1-13	52	104450101	A - 4-1	2		V2 - 1-2-1-15	76
062400806	N - 2	52		Q1 - 1-26-18	54		A - 4-2	2		V3 - 1-3-1-17	78
062401006	Z - 76	90	0A4400605	Q2 - 42	60		A - 10	2	118064001	Z - 34	88
062401216	S - 40-7	68	0A4400805	T - 1-1-6	72		A - 400	2	118837001	Z - 27	88
062404005	R1-600-17	64	0A5400806	Q1 - 1-9	54		D1 - 501	24	119707003	V4 - 2-4-3	80
	W2-600-11-10	84		R1 - 500-15	62	104525001	Sp1	91	119708001	V4 - 2-4-4	80
	W3-600-11-10	86		R1 - 600-22	64	104567101	F - 22	32	120448001	H - 1-13	36
062501406	Z - 35-11-2	88		R2 - 700-19	66		F - 702	32	120990001	H - 1-14	36
	Z - 35-11-4	90		S - 17	68	104821001	A - 30	2	121007001	J - 42	38
062660412	E - 14-1-3	28		S - 31	70	105812003	J - 15	38		K - 8	42
	E - 14-2-1-3	28	0A5401006	S - 5	68	106129002	L - 5-5	46	122991001	Z - 14	88
062660712	E - 14-1-7	28		S - 11	68	106147002	L - 717	48	123006001	B1 - 15	6
	E - 14-2-1-7	28		S - 41	68	106629002	A - 14	2	123882001	E - 30	28
062670412	G - 31	34		S - 43	68		A - 403	2	133188001	V4 - 2-4-2	80
	K - 16	42	0A5401206	Q1 - 1-5	54	107017002	A - 705	4	133740006	Z - 55	90
062670512	C5 - 603	20		Q1 - 1-10	54	107038003	C2 - 90-2-11	14	139096001	C4 - 91-6-1	18
	F - 28	32	0A5401606	Q2 - 50	60		C3 - 90-5-10	16		C5 - 92-6-1	20
	F - 39	32	0A5403006	Q1 - 1-8	54		C4 - 91-15	18	140392009	A - 5	2
	F - 52	32	0A5501205	R1 - 20	62		C5 - 92-16	20		A - 7	2
	S - 13	68	100022004	H - 1-26	36	107149001	F - 5	32		A - 401	2
	W2 - 600-7	84	100022005	J - 25	38		F - 13	32	140407002	C2 - 90-2-13	14
	W3 - 600-7	86		J - 26-3	38	107321003	A - 704	4		C3 - 90-5-12	16
062670612	C1 - 55	12		L - 1-1-3	46		M - 4	50	140647101	F - 703	32
	F - 704	32		L - 1-2-3	46	107415014	Sp2	92		S - 40-5	68
	G - 24	34		L - 4	46	107453001	D2 - 706	26	140726000	B1 - 6	6
	M - 21	50		L - 710	48	107606001	Sp1	91	141492001	J - 26-2	38
062671012	M - 14	50	100032004	C1 - 43	10	107779001	Z - 29	88		L - 1-1-2	46
062671016	Z - 67-2	90		J - 51	40	107780001	Z - 31	88		L - 1-2-2	46
062680512	H - 1-18	36	100090004	E - 2	28	108802001	C1 - 1-4	10	141542001	K - 17	42
062680612	C1 - 38	10	100136001	G - 20	34		F - 701	32	141590001	H - 1-25	36
062680612	D1 - 16	24		H - 1-20	36	109239002	A - 24	2	141786001	E - 1	28
062680612	F - 7	32	100197002	C4 - 48	18	109714000	Z - 5	88	142443001	Z - 26	88
062680612	F - 31	32		C5 - 48	20		Z - 12	88	142628001	C2 - 90-2-5	14
062680612	H - 3	36	100242003	B1 - 20	6		Z - 21	88		C3 - 90-5-4	16
062680712	B1 - 16-2-8	6		C5-92-12-13	20	109763002	L - 16	46	142656001	V4 - 2-5	80
062680812	B1 - 16-1-8	6		W2-600-1-13	84	110161004	J - 37	38	142721001	Z - 33	88
	K - 509	42		W3-600-1-13	86		L - 721	48	142990001	Z - 35-10-3	88
	L - 9	46	100250001	B1 - 13	6	110168001	C4 - 91-22	18	143549050	K - 605-5	44
	W1 - 20-12	82	100260001	C2 - 90-2-21	14		C5 - 92-23	20	143591001	C4 - 91-7	18
062681012	A - 26	2		C3 - 90-5-20	16	110233001	J - 36	38		C5 - 92-7	20
	C1 - 24	10	100281001	D1 - 8	24	110251001	M - 9-1	50	143882001	Z - 9	88
062681212	D2 - 722	26	100360003	J - 54	40		M - 9-2	50	144105000	H - 1-23	36
	H - 2	36	100402004	G - 17	34	110367001	J - 31	38	144110001	H - 1-21	36
062681412	B2 - 30-4	8		H - 1-7	36	111140002	J - 50	40	144226001	Z - 51	90
062710612	G - 2-2	34	100645003	A - 34	2	114294001	G - 9	34	144458001	B1 - 23	6
062710812	A - 710	4		K - 511	42	114483002	Z - 22	88	144588001	Sp1	91
	M - 2	50		K - 609	44	114486002	Z - 6	88	144712001	B1 - 2-1	6
	S - 401	70		L - 714	48	115007001	S - 501	70	145087001	C5 - 92-12-9	20
062711012	A - 18-2	2		W1 - 20-9	82		W1 - 20-5-13	82		W2 - 600-1-9	84
	A - 42	2	100659001	K - 704	44	115186001	G - 19	34		W3 - 600-1-9	86
062761012	A - 405	2	100666002	V4 - 2-2	80	115188001	G - 21	34	145318001	C1 - 40	10
062771012	L - 701	46	100887001	Z - 30	88	116629001	K - 10	42		C1 - 42	10
070688850	C1 - 16	10	101268002	V4 - 2-1-5	80	116694001	V4 - 2-4-6	80	145446001	G - 16	34

索引 / INDEX

CODE	REF.NO	Page	CODE	REF.NO	Page	CODE	REF.NO	Page	CODE	REF.NO	Page
145446001	G - 22	34	152686101	Sp1	91	153567000	C3 - 90-5-18	16	156109001	C1 - 44-6	12
	H - 1-22	36	152690401	Sp1	91	153568001	C2 - 90-2-17	14	156112003	Z - 35-6	88
145465001	B1 - 16-1-5	6	152718001	C2 - 90-2-7	14		C3 - 90-5-16	16	156206001	W1 - 20-13	82
	B1 - 16-2-5	6	152756001	C1 - 10	10	153569001	C2 - 90-2-17	14	156206101	K - 15	42
145472001	D2 - 716	26	152760051	C1 - 8	10	153596001	J - 20	38	157968001	H - 1-17	36
145478101	C2 - 90-2-16	14	152788000	C2 - 90-2-18	14	153597001	L - 5-2	46	159111001	K - 706	44
	C3 - 90-5-15	16		C3 - 90-5-17	16	153924001	C1 - 1-3	10	159565000	F - 23	32
	L - 2	46	152822101	K - 2	42		F - 45	32	159574101	H - 1-19	36
145519001	Sp1	91	152827001	K - 13	42	154235001	C5 - 92-12-7	20	159610301	Sp1	91
145547001	F - 27	32	152842059	A - 22	2		W2 - 600-1-7	84	159612001	Sp1	91
145646014	Sp2	92	152872001	G - 8	34		W3 - 600-1-7	86	159613051	Sp1	91
145646025	Sp2	92	152881001	G - 27	34	154236001	C5 - 92-12-8	20	159805001	G - 15	34
146581002	C2 - 90-2-20	14	152883000	G - 29	34		W2 - 600-1-8	84	159828101	C2 - 90-2-15	14
	C3 - 90-5-19	16	152884001	G - 30	34		W3 - 600-1-8	86		C3 - 90-5-14	16
147777000	B1 - 16-1-9	6	152889001	G - 23	34	154237001	C5-92-12-11	20	159905001	J - 14	38
	B1 - 16-2-9	6	152890001	G - 25-1	34		W2-600-1-11	84		L - 716	48
148133001	C1 - 44-4	12		Sp2	92	154252001	W3-600-1-11	86	181995001	E - 6	28
148196000	D2 - 711	26	152891101	G - 26	34		C5 - 601	20	183493001	C1 - 3	10
148197000	D2 - 712	26	152948001	F - 33	32		W2 - 600-5	84	200190001	V4 - 2-3	80
148738000	F - 4	32	152956001	F - 42	32	154253001	W3 - 600-5	86		Z - 42	90
	F - 40	32	152969001	F - 38	32		C5 - 602	20		Z - 62	90
	F - 41	32	152973001	C1 - 7-5	10		W2 - 600-6	84	218859001	Q2 - 2-1-5	58
148764001	L - 719	48	153050000	E - 14-1-8	28	154256101	W3 - 600-6	86		Q2 - 2-2-5	58
148847001	J - 13	38	153112001	K - 502	42		C6 - 200-3	22		Q2 - 2-3-5	58
	R1 - 23	62		W1 - 20-3	82		W2 - 600-3	84		Q2 - 2-4-5	58
	R2 - 23	66	153242000	Q1 - 1-26-15	54		W3 - 600-3	86		Q2 - 2-7-5	58
148904001	V4 - 2-1-3	80		Z - 102	90	154339101	Sp2	92		S - 25	68
149173001	Z - 25	88	153364000	C2 - 90-2-1	14	154340101	Sp1	91	224514001	Q2 - 2-1-4	58
149287000	W1 - 20-16	82		C3 - 90-5-1	16	154341001	Sp1	91		Q2 - 2-2-4	58
149796001	R1 - 10	62	153367001	C2 - 90-2-4	14	154342001	Sp1	91		Q2 - 2-3-4	58
	R2 - 10	66		C3 - 90-5-3	16	154467001	Z - 4-2	88		Q2 - 2-4-4	58
149809000	Q2 - 45	60	153368001	C2 - 90-2-8	14	154512001	C3 - 90-5-7	16	228475000	F - 44	32
	Q2 - 48	60		Ga1	93	154514001	S - 40-9	68		J - 55	40
	R1 - 500-13	62	153369001	C2 - 90-2-9	14	154528001	H - 1-12	36		K - 608	44
	R1 - 600-20	64		C3 - 90-5-8	16	154596000	J - 21	38		Q1 - 12	54
	R2 - 700-17	66		C4 - 91-13	18	154599000	J - 6	38		R1 - 13	62
149831101	C5-92-12-10	20	153370001	C2 - 90-2-10	14	154663001	Sp1	91		R2 - 13	66
	W2-600-1-10	84		C3 - 90-5-9	16	155055001	S - 3-1	68		S - 22	68
	W3-600-1-10	86		C4 - 91-14	18	155559001	M - 18	50		V2 - 1-2-1-7	76
150173003	Z - 35-7	88		C5 - 92-15	20	155578000	B1 - 21	6		V3 - 1-3-1-9	78
150174000	Z - 35-4-3	88	153372001	C2 - 90-2-8	14	156076101	C1 - 44-1	10		W2 - 600-15	84
	Z - 35-5-1	88		Ga1	93	156077001	C1 - 44-7	12		W3 - 600-15	86
150179002	Z - 35-8-1	88	153377001	C1 - 44-2	10	156080000	C1 - 44-8	12	231071001	J - 17	38
150182000	Z - 35-2	88	153378001	C1 - 44-3	12	156082001	C6 - 210-5-2	22	232384001	Q1 - 1-26-7	54
150183000	Z - 35-10-2	88	153380001	C1 - 44-9	12		Ga1	94	291662003	V3 - 1-4	78
150206002	Z - 35-4-1	88	153383001	C1 - 45	12	156083001	C6 - 210-5-1	22	402887001	E - 14-1-6	28
150460001	D2 - 704	26	153384001	C1 - 46	12		Ga1	94		E - 14-2-1-6	28
150461001	D2 - 705	26	153391001	C1 - 47-1	12	156084001	C6 - 110-5	22	525664000	S - 30	68
150551000	G - 11	34		Ga1	93		Ga1	94		S - 30	70
150592001	A - 29	2	153392001	C1 - 47-2	12	156085001	C6 - 210-4-2	22	552907000	S - 4	68
	A - 43	2		Ga1	94		Ga1	94		S - 10	68
151907001	L - 709	48		Ga1	93	156086001	C6 - 210-4-1	22		S - 42	68
152240101	B1 - 22-1	6	153393001	C1 - 4	10		Ga1	94	623033000	D2 - 703	26
152242001	B1 - 24	6	153493001	C6 - 210-1-2	22	156087001	C6 - 110-4	22	625010000	S - 12	68
152243001	B1 - 25	6		Ga1	93		Ga1	94	J02657001	Q2 - 2-1-3	58
152245101	E - 4	28		Ga1	94	156088001	C6 - 210-6-2	22		Q2 - 2-2-3	58
152678201	E - 11	28	153498001	C6 - 210-1-1	22		Ga1	94		Q2 - 2-3-3	58
	E - 16	28		Ga1	93	156089001	C6 - 210-6-1	22		Q2 - 2-4-3	58
152682101	Sp1	91	153503001	C6 - 110-1	22		Ga1	94		Q2 - 2-7-3	58
152683101	E - 14-1-4	28		Ga1	93	156090001	C6 - 110-6	22	J80868001	U - 1	72
	E - 14-2-1-4	28	153567000	C2 - 90-2-19	14		Ga1	94	S00480000	S - 34	68
152684101	E - 14-1-5	28		Ga1	93	156108001	C1 - 44-5	12		V4 - 2-1-12	80
	E - 14-2-1-5	28		Ga1	94						

索引 / INDEX

CODE	REF.NO	Page	CODE	REF.NO	Page	CODE	REF.NO	Page	CODE	REF.NO	Page
S00554000	Q1 - 1-17	54	S10125000	D1 - 500	24	S19748001	M - 12	50	S36260000	V3-1-3-1-7-2	78
S00705001	J - 47	38	S10162201	F - 15	32	S20164001	A - 28	2	S36682000	V1-1-1-1-18	74
S01005000	Z - 35-4-4	88	S10174000	H - 1-15	36	S21775001	C4 - 91-6	18	S37057001	S - 400-1	70
S01199003	V4 - 2-4-1	80	S10195101	J - 30	38		C5 - 92-6	20		S - 504	70
S01603009	V4 - 2-4	80	S10202201	J - 41	38	S21798001	Z - 35-8	88		W1 - 20-5-8	82
S01998001	L - 13	46	S10208001	J - 46	38	S21875001	K - 712	44	S37059001	Q1 - 1-24	54
	M - 8	50		Z - 18	88	S23337001	A - 16	2		Wa	96
S02269001	B1 - 22-2	6	S10208002	J - 46	38	S23377001	C6 - 210-2-2	22	S37060001	Q1 - 1-25	54
S02354001	J - 24	38		Z - 18	88		Ga1	93		Wa	96
	L - 3	46	S10208003	J - 46	38	S23378001	C6 - 210-2-1	22	S37806109	K - 514	42
S02429101	E - 14-2-1-2	28		Z - 18	88		Ga1	93		W1 - 20-5-11	82
S02429201	E - 14-1-2	28	S10209101	J - 48	38	S23379001	C6 - 110-2	22	S37915009	A - 12	2
S02438001	G - 25-3	34	S10210201	J - 49	38		Ga1	93	S37926101	B1 - 16-1-7	6
	Sp2	92	S10211001	Ga2	95	S23836001	J - 8	38	S37928019	Sp2	92
S02439001	G - 25-4	34	S10212101	Sp1	91	S23880000	R1 - 500-10	62	S37932101	C1 - 1-5	10
	Sp2	92		Ga2	95		R1 - 600-13	64		C1 - 7-2	10
S02445001	A - 701	4	S10213001	Ga2	95		R2 - 700-13	66	S37933001	C1 - 1-6	10
S02652001	J - 7	38	S10229101	L - 704	46	S24729000	L - 724	48		C1 - 7-3	10
S02654001	J - 8-1	38	S10239001	L - 22-1	46	S25127001	Ga2	95	S37934101	C1 - 2	10
S02664051	K - 605-3	44	S10371001	D2 - 723	26	S25456001	K - 507	42	S37940001	C1 - 23	10
S02665050	K - 605-4	44	S10372100	D2 - 724	26		K - 713	44	S37942100	C1 - 27	10
S02747101	Z - 35-4-5	88	S10377101	C4 - 91-3	18		W1 - 20-5-5	82	S37944100	C1 - 28	10
S02763402	Z - 35	88		C5 - 92-3	20		W1 - 20-7	82	S37968001	D1 - 9	24
S02777001	Z - 35-4	88	S10378101	C4 - 91-4	18	S27836001	C6 - 210-3-2	22	S37978251	E - 5	28
S02778002	Z - 35-9	88		C5 - 92-4	20		Ga1	93	S37983001	F - 6	32
S02786002	Z - 35-10	88	S10469001	G - 18	34	S27837001	C6 - 210-3-1	22	S37985000	F - 24-1	32
S02787002	Z - 35-10-1	88	S10478000	F - 10	32		Ga1	93	S37986000	F - 25	32
S03677001	D2 - 728	26	S11244001	J - 52	40	S27838001	C6 - 110-3	22	S37987001	F - 29	32
S03800001	C4 - 91-19	18	S11949000	Q1 - 1-16	54		Ga1	93	S37988000	F - 30	32
	C5 - 92-20	20	S12404000	R1-500-5-2-1	62	S28741000	R1 - 600-18	64	S37991109	H - 1-1	36
S04897000	R1 - 12	62		R1 - 600-8-1	62		W2 - 600-12	84	S37992100	H - 1-2	36
	R2 - 12	66		R2 - 700-8-1	66	S29017000	W3 - 600-12	86	S37993000	H - 1-3	36
S04905000	L - 722-2	48	S12441001	G - 33	34	S29019000	V3 - 1-5	78	S37994001	H - 1-5	36
S05665001	C5 - 92-12-6	20	S12634009	C5 - 92-12-1	20	S29023000	P - 1-1	52	S37995101	H - 1-6	36
	W2 - 600-1-6	84		W2 - 600-1-1	84	S29023000	T - 1-1-7-2	72	S37996001	H - 1-8	36
	W3 - 600-1-6	86		W3 - 600-1-1	86	S29997001	Ga2	95	S37997001	H - 1-11	36
S06548001	Sp1	91	S12639001	C5-92-12-15	20	S30033001	L - 5-3	46	S37998001	H - 1-16	36
S06706001	Z - 15	90		W2-600-1-15	84	S30280000	T - 1-1-7-6	72	S38002201	J - 3	38
S07333001	F - 2	32		W3-600-1-15	86	S30450001	Ga2	95	S38003101	J - 9	38
S07456000	F - 3	32	S12642009	C5-92-12-15	20	S30925001	Ga2	95	S38004002	J - 11	38
S08030000	Q1 - 1-26-16	54		W2-600-1-16	84	S30926001	Ga2	95	S38004003	J - 11	38
	Z - 101	90		W3-600-1-16	86	S31006001	L - 18	46	S38004004	J - 11	38
S08178000	R1 - 11	62	S12668001	K - 703	44	S31012001	D2 - 717	26	S38011001	J - 34	38
	R2 - 11	66	S12699000	G - 11	34	S31013001	D2 - 718	26	S38012001	J - 40	38
S09043000	E - 14-2-1-8	28	S13385001	K - 702	44	S31032001	G - 13	34	S38015001	J - 43	38
	F - 32	32	S13399001	D2 - 727	26	S31551209	R1 - 500-1	62	S38016001	J - 44	38
	F - 700	32	S16290001	E - 23	28		R2 - 700-1	66	S38024101	K - 6	42
S09212001	C1 - 3-1	10	S17871101	D2 - 708	26	S31570409	R1 - 600-1	62	S38025101	K - 7	42
S09228000	R1 - 500-4	62	S18093100	F - 26	32		W2-600-11-1	84	S38032001	L - 11	46
	R1 - 600-4	62		Z - 4-4	88		W3-600-11-1	86	S38033001	L - 14	46
	R2 - 700-4	66	S18415101	C4 - 91-18	18	S31760000	Q1 - 1-18	54	S38039209	Z - 4	88
S09318101	R1 - 500-2	62		C5-92-12-22	20	S31952001	L - 21	46	S38040209	Z - 4-1	88
	R1 - 600-2	62		C5 - 92-19	20	S32235001	J - 18	38	S38044001	Z - 59	90
	R2 - 700-2	66		R1-500-5-1-3	62	S32335100	S - 400-2-1	70	S38045109	Z - 19	88
S10058001	C4 - 91-5	18		R1 - 600-7	62		S - 503-1	70	S38059000	K - 603	42
	C5 - 92-5	20		R2 - 700-7	66	S33006001	W1 - 20-5-7-1	82	S38060000	V2 - 1-2-1-17	76
S10091201	A - 407	2		W2-600-1-22	84	S33251001	Z - 52	90		V3 - 1-3-1-19	78
S10103001	D1 - 302	24		W2-600-11-8	84	S34348001	D2 - 790	26	S38080001	B2 - 30-2	8
S10105001	D1 - 14	24		W3-600-1-22	86	S34883001	Ga2	95	S38082001	B2 - 30-3	8
S10111101	D2 - 719	26		W3-600-11-8	86	S34986000	M - 11	50	S38093000	Q1 - 1-4	54
S10112001	D2 - 720	26	S19662001	D1 - 10	24	S36260000	F - 11	32	S38107100	Q1 - 1-12	54
S10113301	D2 - 721	26	S19748001	L - 8	46		V1 - 1-1-1-7-2	74	S38108000	Q1 - 1-13	54
S10123001	L - 720	48		M - 5	50		V2 - 1-2-1-5-2	76	S38109100	Q1 - 1-14	54

索引 / INDEX

CODE	REF.NO	Page	CODE	REF.NO	Page	CODE	REF.NO	Page	CODE	REF.NO	Page
S38110000	Q1 - 1-15	54	S39110001	C5 - 49	20	S42017109	K - 508	42	S43275000	Q1 - 1-19	54
S38112001	Q2 - 2-1	58	S40217001	Ga2	95		W1 - 20-5-6	82	S43276000	Q1 - 1-20	54
S38113000	Q2 - 2-1-1	58	S40616001	Q2 - 40-1	60	S42018109	K - 512	42	S43277000	Q1 - 1-21	54
	Q2 - 2-4-1	58	S40620000	Q2 - 41	60		W1 - 20-5-9	82	S43459001	C6 - 100-3	22
S38114000	Q2 - 2-2	58	S40621000	Q2 - 43	60	S42019001	C5 - 92-12-3	20		W2 - 600-10	84
S38115000	Q2 - 2-2-1	58		Q2 - 46	60		W2 - 600-1-3	84		W3 - 600-10	86
	Q2 - 2-3-1	58	S40622000	Q2 - 44	60		W3 - 600-1-3	86		Sp2	92
	Q2 - 2-7-1	58		Q2 - 47	60	S42020001	C5 - 92-12-14	20	S43679101	R1 - 500-5	62
S38116000	Q1 - 1-23	54		R1 - 500-12	62		W2-600-1-14	84	S43680001	R1 - 500-5-1	62
S38117000	Q2 - 2-3	58		R1 - 600-19	64		W3-600-1-14	86	S43682100	R1 - 500-5-2	62
S38118000	Q2 - 2-2-2	58		R2 - 700-16	66	S42021001	C5-92-12-17	20		R1 - 600-8	62
S38120000	Q2 - 2-5	58	S40623000	Q2 - 49	60		W2-600-1-17	84		R2 - 700-8	66
S38123000	Q2 - 3-1	58	S40628000	R1 - 500-3	62		W3-600-1-17	86	S43683001	R1-500-5-1-2	62
S38126000	Q2 - 3-2-2	58		R1 - 600-3	62	S42030001	C6 - 200-1-2	22		R1 - 600-6	62
	Q2 - 3-3-2	60		R2 - 700-3	66		Sp2	92		R2 - 700-6	66
S38133000	Q2 - 2-1-2	58	S40629000	R1 - 500-9	62	S42031001	C6 - 200-1-1	22		W2-600-11-6	84
	Q2 - 2-3-2	58		R1 - 600-12	64		Sp2	92		W3-600-11-6	86
S38143000	Q1 - 11-1	54		R2 - 700-12	66	S42032001	C6 - 200-2-2	22	S43684001	R1-500-5-1-1	62
S38144100	S - 14-2-1	68	S40635001	Q2 - 40	60		Sp2	92	S43686000	R1 - 500-11	62
	S - 14-2-1	70	S40640001	Z - 35-5	88	S42033001	C6 - 200-2-1	22		R1 - 600-14	64
S38146000	S - 14-2-2	68	S40641001	Z - 35-11	88		Sp2	92		R2 - 700-14	66
	S - 14-2-2	70	S41013001	Ga2	95	S42034001	C6 - 100-1	22	S43687001	R1 - 1-1	62
S38147000	S - 14-2-3	68	S41060109	A - 709	4		Sp2	92		R2 - 1-1	66
	S - 14-2-3	70	S41202151	K - 605	42	S42035001	C6 - 100-2	22	S43687002	R1 - 1-2	62
S38148000	S - 16	68	S41203051	K - 605-1	42		Sp2	92		R2 - 1-2	66
S38155000	P - 1-9	52		S - 500-1	70	S42067101	C1 - 1-1	10	S43688001	R1 - 1-3	62
S38168001	V1 - 1-1-1-3	74	S41204050	K - 605-2	44	S42069001	C1 - 7	10		R2 - 1-3	66
	V3 - 1-3-1-3	78		S - 500-2	70	S42070001	C1 - 7-1	10	S43688002	R1 - 1-4	62
S38169201	V1 - 1-1-1-4	74		W1 - 20-5-1-1	82	S42083001	C1 - 41	10		R2 - 1-4	66
	V2 - 1-2-1-2	76	S41205001	K - 504	42	S42084201	C1 - 44	10	S43693000	D2 - 702	26
S38169201	V3 - 1-3-1-4	78		W1 - 20-5-3	82	S42086101	C1 - 44-10	12	S43696100	R1 - 600-15	64
S38170001	V1 - 1-1-1-6	74	S41206001	K - 505	42	S42087300	C2 - 90-2	14		R2 - 700-15	66
	V2 - 1-2-1-4	76		W1 - 20-5-4	82	S42088001	C2 - 90-2-2	14		W2-600-11-7	84
	V3 - 1-3-1-6	78	S41207000	K - 506	42	S42089001	C2 - 90-2-3	14		W3-600-11-7	86
S38177001	V1 - 1-1-1-12	74		W1 - 20-6	82		C3 - 90-5-2	16	S43900001	L - 705	46
	V2 - 1-2-1-11	76	S41222101	G - 25-2	34	S42090300	C2 - 90-2	14	S43901001	L - 708	48
	V3 - 1-3-1-13	78		Z - 64	90	S42091300	C2 - 90-2	14	S43902001	L - 711	48
S38178101	V1 - 1-1-2	74		Sp2	92	S42092300	C2 - 90-2	14	S43903001	L - 718	48
	V2 - 1-2-2	76	S41238001	D1 - 11	24	S42093300	C3 - 90-5	16	S43904101	L - 723	48
	V3 - 1-3-2	78	S41239001	D1 - 300	24	S42260000	Q1 - 1-11	54	S43907209	A - 707	4
S38179101	V1 - 1-1-3	74	S41271000	C4 - 91-23	18	S42750209	A - 17-2	2	S43909001	L - 715	48
	V2 - 1-2-3	76		C5 - 92-24	20	S42751109	A - 17-2-1	2	S43990001	C6 - 302	22
	V3 - 1-3-3	78	S41284301	K - 11	42	S42752000	A - 17-2-2	2		Ga1	94
S38180000	V1 - 1-1-1-17	74	S41290301	A - 708	4	S42756101	B1 - 16-2-7	6	S43991001	C6 - 302	22
	V2 - 1-2-1-16	76	S41656001	K - 500	42	S42827200	F - 24-2	32		Ga1	94
	V3 - 1-3-1-18	78		W1 - 20-1	82	S42839101	D2 - 710	26	S43992001	C6 - 302	22
S38203000	Q1 - 1-26-5	54	S41657001	K - 516	42	S42849101	D2 - 726-1	26		Ga1	94
S38205000	Q1 - 1-26-9	54		W1 - 20-10	82	S42859001	K - 700	44	S44010001	A - 31	2
S38208000	Q1 - 1-26-14	54	S41658000	C4 - 91-1	18	S42864101	K - 701	44	S44287000	R1 - 500-14	62
S38349001	Z - 75-2	90		C5 - 92-1	20	S42870201	L - 700	46		R1 - 600-21	64
	Wa	96	S41660001	C4 - 91-12	18	S42871201	L - 703	46		R2 - 700-18	66
S38350001	Z - 75-2	90		Ga1	93	S42873101	L - 702	46	S44483001	Z - 67-1-1	90
	Wa	96	S41703000	C1 - 12	10	S42880001	D2 - 715	26	S44485001	Z - 67-1-2	90
S38352101	Q1 - 20	56	S41705001	C1 - 15	10	S43175000	Q1 - 1-26-11	54	S44600001	K - 501	42
	Wa	96	S42007001	C5 - 92-12	20	S43176000	Q1 - 1-26-12	54		W1 - 20-2	82
S38353101	Q1 - 21	56		W2 - 600-1	84	S43177000	Q1 - 1-26-1	54	S44629001	A - 920	4
	Wa	96		W3 - 600-1	86	S43178000	P - 1-2	52	S44633001	Sp1	91
S38648001	Z - 35-4-2	88	S42008001	C5 - 92-12-2	20	S43181000	Q1 - 1-26-13	54	S44745109	W2 - 600-11	84
S38744101	S - 40-2	68		W2 - 600-1-2	84	S43184000	Q1 - 1-26-2	54	S44746100	R1 - 600-15-1	64
S39051001	L - 19	46		W3 - 600-1-2	86	S43187000	Q1 - 1-26-20	54		R2 - 700-15-1	66
S39110001	C2 - 49	14	S42009101	C5 - 92-13	20	S43188000	Q2 - 2-6	58		W2-600-11-7-1	84
	C3 - 49	16		W2 - 600-2	84	S43189000	Q1 - 1-26-19	54		W3-600-11-7-1	86
	C4 - 49	18		W3 - 600-2	86	S43201000	Q2 - 3-4	60	S44748001	R1 - 600-5	62

索引 / INDEX

CODE	REF.NO	Page	CODE	REF.NO	Page	CODE	REF.NO	Page	CODE	REF.NO	Page
S44748001	R2 - 700-5	66	S49463100	S - 6	68	S49632001	D1 - 3	24	S49980001	Ga2	95
	W2-600-11-2	84	S49464000	S - 18	68	S49635001	D1 - 4	24	S49982000	F - 12	32
S44749001	W3-600-11-2	86	S49465006	S - 21	68	S49636001	D1 - 5	24	S49983000	F - 20	32
S44750100	R1-600-15-2	64	S49465007	S - 21	68	S49637001	D1 - 6	24	S49984000	F - 21	32
	R2-700-15-2	66	S49465010	S - 21	70	S49638001	D1 - 7	24	S49985000	F - 48	32
	W2-600-11-7-2	84	S49465011	S - 21	70	S49639001	D1 - 15	24	S49986000	F - 49	32
	W3-600-11-7-2	86	S49465012	S - 21	70	S49640101	D1 - 17	24	S49987000	F - 50	32
S44940001	C6 - 210-7-2	22	S49466000	K - 604-2	42	S49641001	D1 - 19	24	S49988001	J - 45	38
	Ga1	94		S - 400-2-2	70	S49642001	D1 - 21	24	S49992000	F - 1	32
S44941001	C6 - 210-7-1	22		S - 503-2	70	S49643001	D1 - 23	24	S49994001	J - 38	38
	Ga1	94		W1-20-5-7-2	82	S49644001	J - 16	38	S49995001	F - 51	32
S44942001	C6 - 100-4	22	S49467001	Q1 - 1	54	S49645001	J - 10	38	S50529000	E - 14-2-2	30
	Sp2	92	S49468001	Q1 - 1-1	54	S49646101	J - 22	38	S50645000	P - 1-10	52
S45083001	G - 32	34	S49469001	Q1 - 1-2	54	S49648001	J - 26	38	S51097000	Z - 75-1	90
S45131001	D2 - 726-2	26	S49470001	Q1 - 1-3	54	S49649001	J - 26-1	38	S51098000	A - 40	2
S45132001	D2 - 726-3	26	S49471000	P - 1-8	52	S49650001	J - 29	38	S51099000	C1 - 17	10
S45133001	D2 - 726-4	26	S49472000	Q1 - 1-26-21	54	S49651001	J - 35	38	S51100001	C1 - 18	10
S45134001	D2 - 726-5	26	S49473000	Q2 - 3-2	58	S49652101	K - 1	42	S51101001	C1 - 21	10
S45135001	D2 - 726-6	26	S49474000	Q2 - 3-2-1	58	S49653001	L - 5	46	S51102001	C4 - 903	18
S45252000	R1 - 600-16	64	S49475000	Q2 - 3-3	60	S49654001	L - 5-1	46	S51103001	C1 - 25	10
	W2-600-11-9	84	S49476000	Q2 - 3-3-1	60	S49655001	L - 5-4	46	S51282001	Z - 35-3	88
	W3-600-11-9	86	S49477000	Q1 - 10	54	S49656001	L - 6	46	S51283001	Z - 35-1	88
S45253000	R1-600-16-1	64	S49478000	Q1 - 11	54	S49657001	L - 7	46	S51449001	Ga2	95
	W2-600-11-9-1	84	S49479001	P - 1	52	S49659001	M - 1-1	50	S51451000	V1 - 1-1-1-9	74
	W3-600-11-9-1	86	S49482000	S - 400-2	70	S49660101	M - 3	50		V2 - 1-2-1-8	76
S45254000	R1-600-16-2	64		S - 503	70	S49661101	M - 7	50		V3 - 1-3-1-10	78
	W2-600-11-9-2	84		W1 - 20-5-7	82	S49662001	M - 17-1	50	S51457109	A - 17-1	2
	W3-600-11-9-2	86	S49484000	P - 1-6	52	S49663001	M - 13	50	S51458109	A - 17-1-1	2
S46131001	V4 - 2	80	S49486000	P - 1-11	52	S49664000	M - 20	50	S51459001	A - 404	2
S46132001	V4 - 2-1	80	S49495000	T - 1-1-3	72	S49665001	L - 1-1	46	S51461001	A - 402	2
S46133001	V4 - 2-1-1	80	S49496001	T - 1-1-4	72	S49666001	L - 1-1-1	46	S51462001	C1 - 30	10
S46134001	V4 - 2-1-2	80	S49497001	T - 1-1-7-1	72	S49667101	V1 - 1-1	74	S51463001	C1 - 31	10
S46135001	V4 - 2-1-6	80	S49510000	T - 1-1-8	72	S49668101	V1 - 1-1-1	74	S51465001	C1 - 37	10
S46136000	V4 - 2-1-7	80	S49582001	B1 - 3	6	S49669100	V1 - 1-1-1-1	74	S51846101	V3 - 1-3	78
S46144100	L - 722	48	S49583001	B1 - 4-1	6		V2 - 1-2-1-1	76	S51847101	V3 - 1-3-1	78
S46145000	L - 722-1	48	S49584101	B1 - 12	6		V3 - 1-3-1-1	78	S51854209	R2 - 700	66
S46544001	C6 - 200-4-2	22	S49585001	B1 - 16-1	6	S49672001	V1 - 1-1-1-2	74	S51855209	R1 - 600	62
	Sp2	92	S49586000	Q1 - 1-26-3	54		V3 - 1-3-1-2	78	S51856001	C1 - 39	10
S46545001	C6 - 200-4-1	22	S49587001	B1 - 16-1-1	6	S49673000	V1-1-1-1-10	74	S51857101	C1 - 1	10
	Sp2	92		B1 - 16-2-1	6		V2-1-2-1-9	76	S51858001	C1 - 1-2	10
S46694000	V1-1-1-1-19	74	S49588001	B1 - 16-1-2	6		V3-1-3-1-11	78	S51859101	G - 5	34
	V2-1-2-1-18	76		B1 - 16-2-2	6	S49674001	V1-1-1-1-11	74	S51860001	C1 - 47-3	12
	V3-1-3-1-20	78	S49589001	B1 - 16-1-4	6		V2-1-2-1-10	76	S52091000	T - 1-1-2	72
S46703000	T - 1-1-7-3	72		B1 - 16-2-4	6		V3-1-3-1-12	78	S52099001	C2 - 90-2-12	14
S46734001	L - 12	46	S49593000	B1 - 19	6	S49675101	V2 - 1-2	76		C3 - 90-5-11	16
S47091001	B1 - 16-1-3	6	S49603000	Z - 11	88	S49676101	V2 - 1-2-1	76	S52100001	C6 - 905-1	22
	B1 - 16-2-3	6	S49604000	Z - 20	88	S49685000	E - 14-1-11	28		Ga1	94
S47270001	B2 - 44	8	S49605001	E - 8	28	S49688101	B1 - 1-1	6	S52744000	K - 604-1	42
S47335101	H - 5	36	S49609001	E - 13	28	S49689001	B1 - 16-1-6	6	S52834201	B2 - 30-1	8
S47592000	Q2 - 2-4	58	S49615009	W1 - 20	82		B1 - 16-2-6	6	S52836000	B2 - 47	8
S47594000	Q2 - 2-7	58	S49616009	W1 - 20-5	82	S49934009	S - 400	70	S52838000	B2 - 35	8
S47595000	Q2 - 2-4-2	58	S49618000	F - 53	32	S49938000	Q1 - 1-26-22	54	S52839200	B2 - 36	8
	Q2 - 2-7-2	58	S49619001	W1 - 20-5-1	82	S49939101	Q1 - 1-26	54	S53031001	Q1 - H-1	56
S47692000	Q1 - 1-7	54	S49620000	F - 17	32	S49947000	W1 - 20-14	82	S53033001	Q1 - H-2	56
S48578000	P - 1-14	52	S49622000	F - 19	32	S49955001	C6 - 905-2	22	S53034001	Q1 - H-3	56
S48579000	T - 1-1-7-4	72	S49623000	F - 34	32	S49955101	Ga1	94	S53035001	Q1 - H-4	56
S48580000	Q1 - 1-26-17	54	S49624000	F - 35	32	S49957000	F - 18	32	S53036001	Q1 - H-5	56
	Z - 103	90	S49625000	F - 36	32		F - 46	32	S53037001	Q1 - H-6	56
S48587000	S - 1	68	S49626000	E - 14-1-10	28	S49958000	F - 47	32	S53038001	Q1 - H-7	56
S48589000	S - 2	68	S49627001	G - 3	34	S49959001	F - 14	32	S53039001	Q1 - H-8	56
S48666001	N - 1	52	S49629201	J - 1	38	S49962000	A - 17-1-2	2	S53040001	Q1 - H-9	56
S49071000	Q1 - 1-26-8	54	S49630001	D1 - 1	24	S49979400	S - 14-1-1	68	S53055100	U - 2	72
S49443000	V4 - 3	80	S49631001	D1 - 2	24	S49980001	Sp1	91	S53091001	C4 - 91	18

索引 / INDEX

CODE	REF.NO	Page	CODE	REF.NO	Page	CODE	REF.NO	Page	CODE	REF.NO	Page
S53092001	C4 - 91-2	18	S55216001	E - 14-2-1-1	28	SA0709001	W3 - 600	86			
	C5 - 92-2	20	S55216301	E - 14-1-1	28	SA1034000	Q1 - 1-26-10	54			
S53094001	C4 - 91-16	18	S55311001	Z - 75	90	SA1579019	Sp2	92			
	C5 - 92-17	20	S55311002	Z - 75	90	SA1645014	Sp2	92			
S53095000	C4 - 91-17	18	S55424001	R1 - 500	62	SA1645025	Sp2	92			
	C5 - 92-18	20	S55432000	S - 703	70	SA1752014	Sp2	92			
S53096001	C4 - 91-21	18	S55433000	S - 704	70	SA1881001	Sp1	91			
	C5 - 92-22	20	S55473000	Q1 - 1-26-4	54	SA1882001	Sp1	91			
S53097001	G - 1	34	S55479001	D1 - 18	24	SA1890001	Sp1	91			
S53098001	C5 - 92	20	S55572001	B2 - 31	8	SA2150001	K - 15	42			
S53099001	C1 - 13	10		B2 - 48	8	SA2173001	Sp1	91			
S53100001	C1 - 19	10	S55627001	Q1 - 54	56	SA2932001	B1 - 2	6			
S53108001	C1 - 33	10	S55629101	S - 40	68	SA3722001	P - 1-7	52			
S53109001	C1 - 36	10	S55630001	S - 40-1	68	SA4104001	Z - 67-1-6	90			
S53117101	A - 409	4	S55632001	S - 40-3	68	SA4141001	D1 - 401	24			
S53118001	R1 - 2-1	62	S55633001	Z - 70	90	SA4152001	Z - 67-1	90			
	R2 - 3-1	66	S55658000	E - 27	28	U32744000	P - 1-12	52			
	W2 - 600-13	84	S55659000	F - 54	32	U34870001	T - 1-1-7-5	72			
	W3 - 600-13	86	S55663001	Z - 23	88	UA4817000	Q1 - 10-1	54			
S53118002	R1 - 2-2	62	S55889001	T - 1	72	UD2390001	V4 - 2-1-8	80			
	R2 - 3-2	66	S55890001	T - 1-1	72	UL0025000	T - 1-1-7-7	72			
	W2 - 600-14	84	S55891000	T - 1-1-1	72	XA2220050	T - 1-1-10	72			
	W3 - 600-14	86	S55927301	E - 14-1	28	Y51030150	P - 1-15	52			
S53119001	A - 13-1	2	S56017000	B2 - 30-1-1	8						
S53120101	A - 13-2	2	S56018000	B2 - 30-1-2	8						
S53136100	S - 6	70	S56019001	B2 - 30-1-3	8						
S54145001	A - 703	4	S56167000	S - 6-1	68						
S54393001	D2 - 714	26		S - 6-1	70						
S54644000	V1-1-1-1-7-1-1	74	S56167001	S - 6-2	68						
	V2-1-2-1-5-1-1	76		S - 6-2	70						
	V3-1-3-1-7-1-1	78	S56167003	S - 6-3	68						
S54645000	V1-1-1-1-7-1-2	74	S57878001	K - 604	42						
	V2-1-2-1-5-1-2	76	S57925001	A - 23	2						
	V3-1-3-1-7-1-2	78	S57965000	E - 14-2-1-10	30						
S54646000	V1-1-1-1-7-1	74	S57976001	B2 - 50	8						
S54647000	V2-1-2-1-5-1	76	S57977001	B2 - 50-1	8						
S54648000	V1-1-1-1-7	74	S57978001	B2 - 51	8						
S54649000	V2-1-2-1-5	76	S59103001	D2 - 700	26						
S54650000	V3-1-3-1-7	78	S59221001	Sp1	91						
S54691000	V3-1-3-1-7-1	78	S59366000	S - 14-1-1-1	68						
S54771001	W2 - 600	84	S59367000	S - 14-1-1-2	68						
S54984001	C6 - 905	22	S59620001	Ga2	95						
	Ga1	94	S59763000	D1 - 25	24						
S55103201	B1 - 1-2	6	S59871001	J - 22-3	38						
S55104001	B1 - 4-2	6	S59872001	J - 22-2	38						
S55105001	B1 - 16-2	6	S59873001	J - 22-4	38						
S55108001	L - 1-2	46	S59874001	J - 22-1	38						
S55109001	L - 1-2-1	46	S59885001	E - 14-2-1	28						
S55111001	M - 17-2	50	S59886001	E - 14-1-9	28						
S55133000	K - 602	42		E - 14-2-1-9	28						
S55140001	E - 29	28		E - 14-2-1-11	30						
S55144001	D2 - 713	26	S59888201	E - 14-2	28						
S55149100	K - 600	42	S59892001	C1 - 53	12						
S55150000	K - 601	42		K - 711	44						
S55151000	K - 513	42	S59893001	J - 12	38						
S55157000	D1 - 12	24		K - 707	44						
S55181001	M - 1-2	50		L - 712	48						
S55184000	K - 607	44	S59920001	A - 41	2						
S55199001	L - 22-2	46	S59931001	Z - 35-11-3	90						
S55208000	A - 25	2	SA0037000	Q1 - 1-26-6	54						
S55213001	E - 9	28	SA0048001	W3 - 600-11	86						
S55214000	E - 28	28	SA0049001	J - 22-5	38						
S55215001	E - 19	28	SA0703001	L - 17	46						

brother®

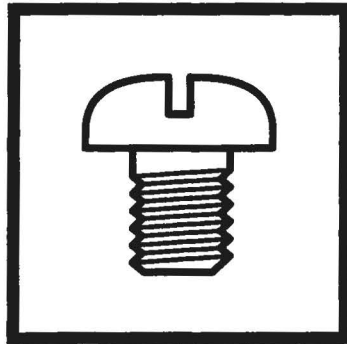

パーツブック
PARTS BOOK

ブラザー工業株式会社 <http://www.brother.co.jp/>

〒467-8561 名古屋市瑞穂区苗代町 15 番 1 号 TEL (052) 824-2392

BROTHER INDUSTRIES, LTD. <http://www.brother.com/>

15-1, Naeshiro-cho, Mizuho-ku, Nagoya 467-8561, Japan. Phone : 81-52-824-2177

Printed in Japan

KE-434C,435C
SA4035-101
2004.12.ZH (1)

From the library of: Superior Sewing Machine & Supply LLC